

User's Manual

QMS 100 Series Gas Analyzer



<https://mod-e.ru/>

Version 3.2 (1/2012)

Certification

Stanford Research Systems certifies that this product met its published specifications at the time of shipment.

Warranty

This Stanford Research Systems product is warranted against defects in materials and workmanship for a period of one (1) year from the date of shipment.

Service

For warranty service or repair, this product must be returned to a Stanford Research Systems authorized service facility. Some components may be serviceable directly from the supplier. Contact Stanford Research Systems or an authorized representative before returning this product for repair.

Trademarks

Ultra-Torr[®] and VCR[®] are registered trademarks of Swagelok Co.

Tygon[®] is a registered trademark of Norton Co.

All other brand and product names mentioned herein are used for identification purposes only, and are trademarks or registered trademarks of the respective holders.

Information in this document is subject to change without notice.

Copyright © Stanford Research Systems, Inc., 1996, 2000, 2006, 2012. All rights reserved.

Stanford Research Systems, Inc.
1290-D Reamwood Avenue
Sunnyvale, California 94089
408 744 9040

Printed in USA

Table of Contents

Safety	iv
Symbols	v
Fast Start	vi
Specifications	vii
Materials List	ix
Calibration Log	x
Chapter 1. Introduction & Operation	1-1
Introduction	1-2
What's Inside ?	1-4
Operation	1-7
Mass Spectrometry Basics	1-16
Chapter 2. Windows Software	2-1
Overview	2-3
System Requirements	2-4
Getting Started	2-4
Features and Operation	2-6
RGA Head and Scan Parameters	2-13
Display Modes	2-15
General Utilities	2-17
Head Calibration and Security	2-20
RGA On-line Help	2-23
Chapter 3. Measurement Techniques	3-1
Calibration	3-2
Techniques	3-16
Glossary	
References	

Safety



WARNING

Hazardous voltages, capable of causing injury or death, are present in this instrument. Use extreme caution whenever the instrument cover is removed. Always unplug the unit while removing the cover.



Ventilation

The QMS system **requires** forced air cooling to operate at a reasonable temperature. Do not block the air inlet or exhaust on the back of the unit. Components will fail without this cooling.



Lifting

The QMS system is heavy; use care when lifting. Two people are recommended for lifting the system. The handle is provided for occasional use and small distances.

Line Voltage

The QMS system is specified for line power of either 110 V / 60 Hz or 220 V / 50 Hz. The diaphragm pump will only operate on the specified voltage. Operating at other voltages will damage the motor. For 110 V operation use one 3 A fuse. For 220 V operation, two 1½ A fuses must be used in the power entry module.









Exhaust

As shipped, the QMS system exhausts to the atmosphere. If the system is analyzing hazardous gases, the user must make provisions to handle the exhaust from the system. A standard 1/4 inch connection is provided for this purpose.

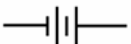

Elastomer Seals

Silicone has been reported to react adversely and irreversibly with the glass contained in an electron multiplier. In systems containing an electron multiplier, do not use silicone greases or oils on seals; use only hydrocarbon based materials.

Symbols you may find on SRS products.

Symbol	Description
	Alternating current
	Caution - risk of electric shock
	Frame or chassis terminal
	Caution - refer to accompanying documents
	Earth (ground) terminal
	Battery
	Fuse
	On (supply)
	Off (supply)

Fast Start

- Connect the power cord to the QMS. Set the four switches on the control panel to off and turn on the main power switch.
- Turn on the diaphragm pump switch and the turbo pump switch. The pumps should begin the startup sequence, which takes several minutes. When both green lights on the display are bright the system is ready to operate.
- Connect the serial cable between the RGA and an available COM port on the computer (typically COM2).
- Install the QMS software on the computer by inserting the first disk and executing the SETUP program.
- Start the QMS program. Under the Utilities menu, choose “RS232 Setup...”. In the dialog box that appears, choose the COM Port that the QMS is connected to and then press the “Connect” button. After a short initialization, the QMS is ready. To confirm communications, under the “Head” menu choose “Get Head Info...”. A box will appear showing information about the QMS.
- Click the filament button  on the toolbar to activate the ionizer. Click the GO button on the tool bar and a scan will begin from 1 to 50 amu. The mass spectrum will show a rough background spectrum.
- Click the filament button  on the toolbar to deactivate the ionizer.
- Loosen the inlet fitting and remove the plug. Attach the capillary inlet and tighten the fitting (finger tight; no tools are required).
- Turn off the Turbo Pump switch and wait for the green light to extinguish. Next, set the Capillary Flow Valve to open. With the flow started, the Turbo Pump switch can be turned back on. Initially, the pump will not start and the light will blink. The pump will start as soon as the pressure falls below 5 mbar. When the pump and capillary flow are started, the first three lights will be on and bright. In the software, select the Utilities|Pressure Reduction menu item and enter the Pressure Reduction Factor for the capillary. Check the box to enable the factor.
- Set the sample flow switch on the control panel to open. Restart the filament and perform a scan. The spectrum of air will be displayed, which can be compared to the example below.

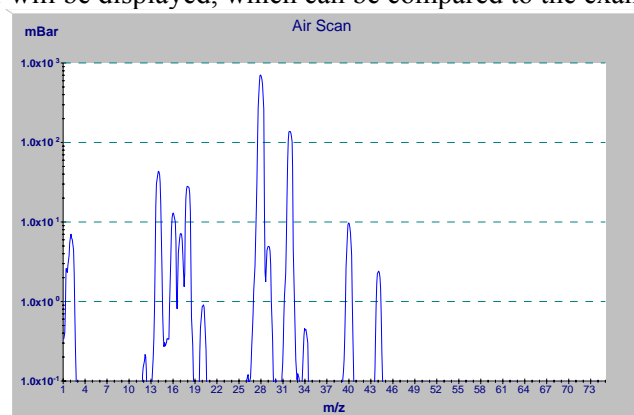

Specifications

Inlet

Type	capillary: available in stainless steel, PEEK, and glass lined plastic
Flowrate	1 to 10 milliliter per minute at atmospheric pressure
Response time	<400 ms
Pressure	selectable from 10 mbar to 1 bar

Mass Spectrometer

Type	quadrupole
Detector	Faraday cup standard electron multiplier optional
Range	1 to 200 atomic mass units (amu)
Resolution	<0.5 amu at 10% of peak height
Detection limit	<10 ppm with Faraday cup detector <1 ppm with electron multiplier
Operating pressure	5×10^{-6} mbar

Connections

Inlet	1/4 inch Ultra-Torr [®] fitting
Exhaust	1/4 inch Swagelok tube adapter
Computer	RS-232C, 28800 baud, DB9 connector
Power	3 pin grounded cable

System

Pumps	hybrid turbomolecular/drag pump, 70 liter/s, ultimate pressure 2×10^{-9} mbar diaphragm pump with ultimate pressure less than 1 mbar
-------	---

	protection class IP44
Materials (see full materials list for details)	construction: SS304 and SS316 insulators: alumina, ceramic seals: Viton, buna-N, and nitrile butyl rubber misc: aluminum, Tygon
General	
Startup time	2 minutes from full stop
Max. Ambient Operating Temperature	35 °C
Power requirement	either 110 V / 60 Hz or 220 V / 50 Hz (not field selectable) less than 600 W total
Dimensions	44 cm H × 20 cm W × 61 cm D (17 in H × 8 in W × 24 in D)
Weight	34 kg (75 lb.)

Materials List

SRS receives many requests for information about corrosion compatibility. It is our policy not to state the compatibility of our system with various corrosive environments. We simply cannot test the myriad combinations of environments that our customers use.

We do provide a list of *all* the materials exposed to the gas being introduced into the system. Our expectation is that users who need to measure corrosive environments already have some type of system that creates, handles and contains the corrosive gases. Given that they have designed and operate said system, they are the best people to decide the compatibility of the materials in our system with the specific corrosive environment.

The QMS system contains the following materials:

Body

- 304 stainless steel - high vacuum tube
- 316 stainless steel - quarter inch tube and fittings
- molybdenum - electrical feedthrough
- ceramic - electrical feedthrough
- AgCuIn - braze material on feedthroughs
- alumina - contained in the RGA
- aluminum - body of diaphragm pump

Replaceable Components

- glass - if an electron multiplier is installed in the RGA
- chromium - surface of the electron multiplier
- IrO₂·ThO₂ - filament of RGA

Seals

- copper - seals in the CF high vacuum flanges
- 316SS - major component of VCR[®] seals
- silver - a thin layer on the VCR[®] seals to prevent gauling
- Viton - o-ring seal in the KF flange
- buna-N - seal in the high conductivity valve
- neoprene - diaphragms in diaphragm pump
- nitrile butyl rubber(NBR) - diaphragm pump valves - backing line
- Tygon[®] - connections to diaphragm pump (can be substituted)

Calibration Log

SRS serial number _____

In the table below are the results of the factory calibration of the inlet and capillary. The factor is entered in the pressure reduction factor dialog box (under the Utilities menu) in the RGA software. Although the RGA software will store the value for you, a written record is recommended.

performed by	capillary ID	length	P high side	test gas	factor
FACTORY					

Chapter 1.

Introduction & Operation

In This Chapter

Introduction	1-2
External Connections	1-3
Operating Orientation	1-4
What's Inside ?	1-4
Gas Handling Subsystem.....	1-4
Mass Spectrometer.....	1-6
Operation.....	1-7
Front Panel Operation.....	1-8
Continuous Sample Mode.....	1-10
Startup Just the Pumps.....	1-10
Startup the Sample Flow.....	1-10
Idle	1-11
Shutdown	1-11
Batch Analyze Mode	1-12
Microcontroller Error Checks	1-13
Operating Modes of the Spectrometer.....	1-14
The RGA as a Mass Spectrometer.....	1-14
The RGA as a Single Gas Monitor.....	1-15
The RGA as a Total Pressure Gauge.....	1-15
Mass Spectrometry Basics	1-16
How Mass Spectra are Interpreted	1-16
Partial Pressure Measurement	1-17
Partial Pressure Sensitivity Factors	1-18

Introduction

The QMS 100 series instruments are modern mass spectrometers designed for the analysis of light gases. The three systems, 100, 200 and 300, differ only in the mass range they can detect. A quadrupole mass spectrometer performs the task of analyzing the gas. The spectrometer operates at high vacuum and therefore, pumps are required to draw the gas into the instrument and maintain the vacuum. State-of-the-art pumps are used that allow the entire instrument to be contained in a small transportable package. The inlet continuously samples gas at low flow rates (several milliliters per minute) making the instrument ideal for on-line analysis. The inlet can be equipped to sample at pressures from above atmospheric to as low as 10 mbar. Not only is data acquired continuously (as opposed to batch sampling employed by gas chromatographs) but the response is fast. A change in composition at the inlet can be detected in less than 1/2 second. The system allows data to be collected quickly; a complete spectrum can be acquired in under one minute and individual masses can be measured at rates up to 25 ms per point. This modern system allows many new applications where the traditional mass spectrometer was too large and heavy.

The QMS can be considered as two main subsystems: gas handling and the analyzer. The analyzer is the quadrupole mass spectrometer, which can only operate in high vacuum. The class of quadrupole mass spectrometer employed belongs to a class referred to as residual gas analyzers (RGA). These spectrometers specialize in large dynamic range measurements of light gases. The gas handling system consists of pump and valves that deliver the sample gas to the analyzer. These components are controlled from the front panel. Using the QMS does not require a detailed understanding of the quadrupole or the principles of the pressure reducing inlet. This manual (User's Manual) discusses the aspects of the instrument that are relevant to someone who only operates and acquires data with the QMS. The instrument contains a microcontroller that assures correct operation of the pumps and valves. The software controls the spectrometer and provides many data acquisition modes, which should fulfill the

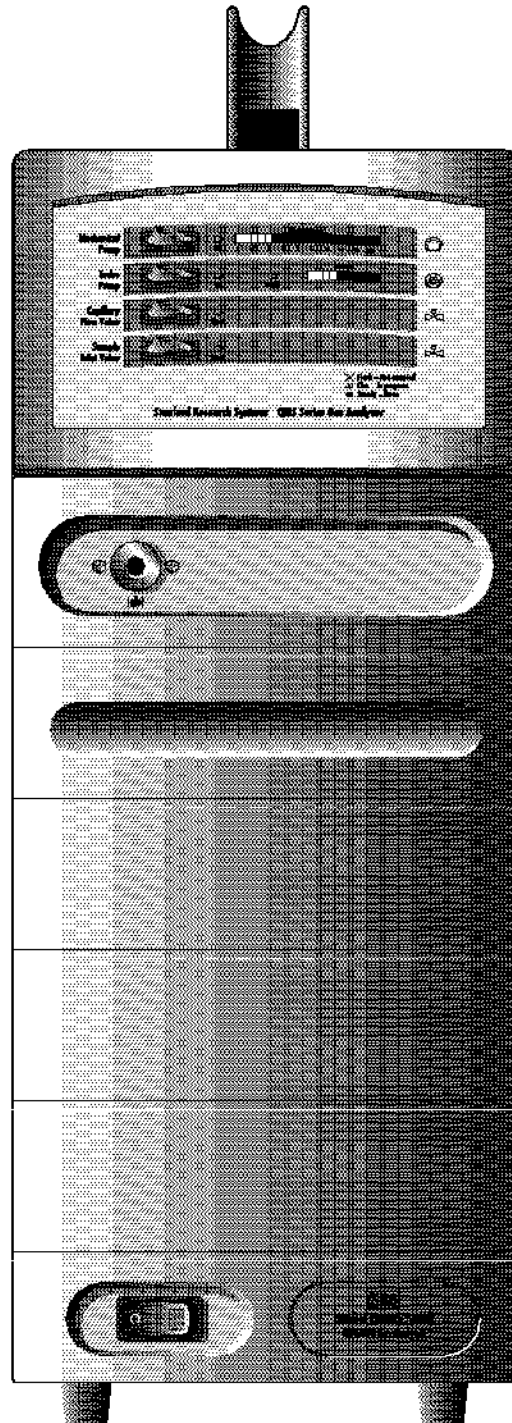

Figure 1-1. Front Panel View

needs of most users. For users with specialized needs, the QMS can be controlled from user programs. The Technical Reference Manual discusses details of the QMS, its programming, and service.

External Connections

The instrument has two gas connections: an inlet on the front panel and an exhaust on the back panel. The inlet connection is a 1/4 inch Ultra-Torr port, which is a high vacuum o-ring seal. The capillary is installed in this port. The port is sealed and released by turning the knurled nut. To release a capillary, loosen the nut 1/2 turn. When installing a capillary, press the end fitting on the capillary completely into the port. Turn the nut finger tight to make the seal.

The o-ring seal relies on clean smooth surfaces and precision machining to achieve the vacuum seal. Excessive force or grease are not required nor helpful. Keep the fittings free from dirt and dust and the port will maintain a quality seal. The o-ring can be inspected for damage by completely removing the nut and ferrule.

The standard capillary shipped with each instrument consists of a 0.005 inch bore PEEK capillary designed to work at atmospheric pressure. The end fitting which attaches to the instrument is a 1/16 to 1/4 tube adapter containing a graphite ferrule. The use of graphite ferrule on capillaries is recommended. Compared to metal ferrules, they do not distort the tube and conform to irregularities in the outside diameter of the capillary. The inlet end of the capillary is fitted with a Luer taper fitting, which is the standard used for syringes. The fitting is not permanently attached at the factory. For long term use, the capillary should be sealed into the fitting. A recess in the back of the fitting is provided for sealant. Many filters and needles are available that can attach to the Luer taper. A 0.22 μm filter is provided with the capillary and should be used when possible. The filter slows the response time of measurements slightly, but protects against clogging and keeps particles out of the QMS.

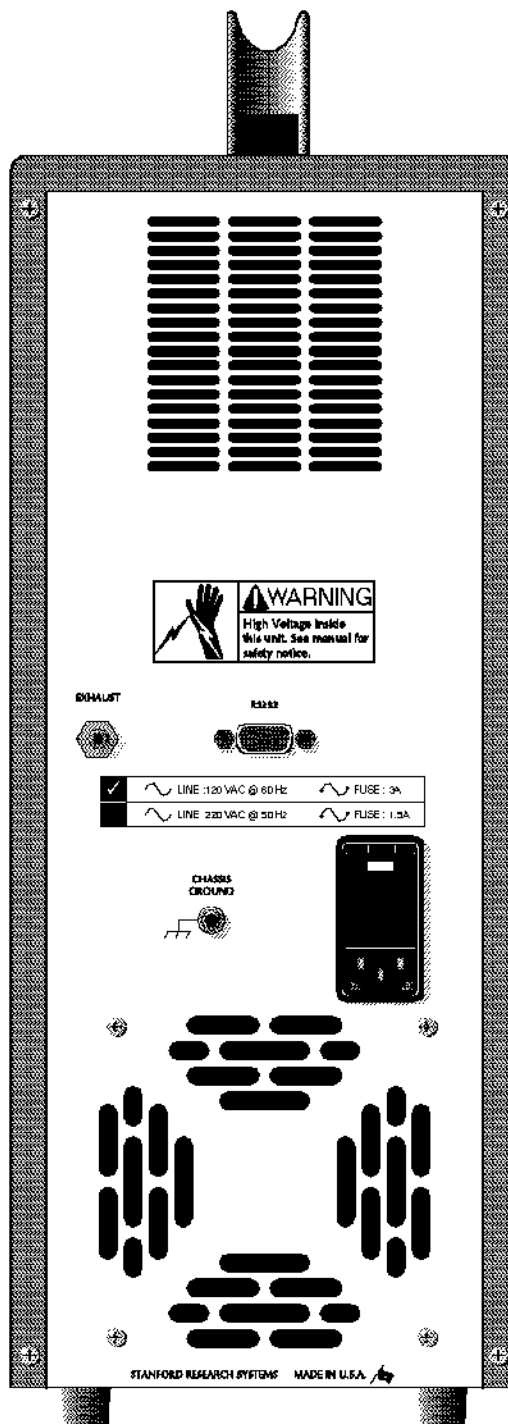

Figure 1-2. Back Panel View

The system exhausts to the rear panel. **All** of the gas drawn into the inlet is exhausted through this port. The port is a 1/4 inch Swagelok tube stub, which can be connected to a wide variety of tube fittings. When sampling hazardous gases, the user must ensure that the exhaust gas is properly handled. The pump behind the exhaust port cannot produce significant pressure above atmospheric; therefore, provide a low resistance path when connecting extra exhaust tubing.

Three electrical connections are located on the back panel: a computer connection, power line, and chassis ground. The computer is connected from its serial port to the 9 pin connector on the back panel. The communications between the instrument and computer uses full hardware handshaking and thereby requires all 9 wires in the cable. Beware that some 9 to 25 pin serial port adapters do not contain all 9 connections. A standard three wire power cord is connected to the module on the back panel. The module also contains the fuse(s). To replace the fuse, first remove the power cord. Next, place a small screwdriver in the slot on the top of the module and pry open the cover. The red fuse tray can then be accessed to replace the fuse. The ground stud is provided to meet CE requirements.

Operating Orientation

The QMS can be operated either standing or laid on its side. The instrument utilizes a pressure gauge that will not operate correctly when the system is tipped front to back. The pumps contain **no** oil or other liquids and therefore gravity has no effect on them. If the system is to be laid on its side, the left side (viewed from front) should be down. If the handle and rubber feet are removed, the system will fit on a shelf in a standard 19" equipment rack. The system can be stored or transported in any orientation.

What's Inside ?

The instrument can be described in terms of two main subsystems: gas handling and mass spectrometer. These two operate independently of each other. The gas handling subsystem draws in the sample gas and transports it to the spectrometer at reduced pressure. The spectrometer analyzes the gas provided to it. The spectrometer belongs to a specific class commonly referred to as *residual gas analyzer* or RGA. In this manual, we use RGA to refer to just the analyzer and QMS to refer to the entire instrument. The following two sections provide a basic description of these subsystems, refer to the Technical Reference Manual for a detailed description. For the curious, the Technical Reference contains an internal photograph in Chapter 1.

Gas Handling Subsystem

Figure 1-3 shows a schematic of the gas handling system. The discussion in this manual assumes that inlet gas is sampled at 1 bar using the standard capillary supplied with each instrument. The system reduces the pressure of the gas approximately 9 decades from the inlet at 1000 mbar to 10^{-6} mbar at the RGA. This large reduction factor is accomplished in two stages. A flow of several milliliters per minute (STP) is drawn into the capillary. The capillary bore diameter and length are such that the pressure at the capillary exit is 1-4 mbar. The standard capillary has an inside diameter of 125 μm and

a length of 0.9 m. Most of the capillary flow does not travel to the RGA, but is bypassed directly to the diaphragm pump. A small part of this flow is drawn through a small aperture (60 μm diameter) into the chamber where the RGA is located. The RGA chamber is maintained at approximately 10^{-6} mbar by a hybrid turbomolecular/drag pump. The flow through the RGA chamber is recombined with the flow that was bypassed around the chamber. The recombination of the two flow streams is the key to the compactness of the QMS instrument; without it, the system would require two pumps.

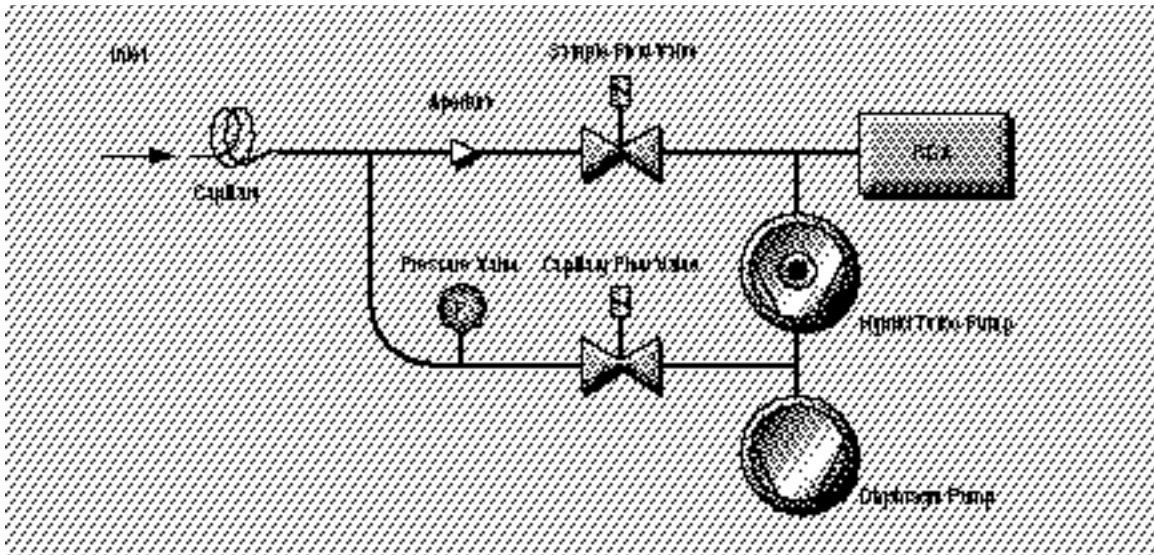

Figure 1-3. Schematic of gas flow.

The bypass flow configuration is also critical to the fast response time achieved by the QMS instrument. A single stage pressure reduction with no bypass flow is possible using leak valves. These valves use precision knife edges to create microscopic gaps. Such an inlet would draw gas at only 5 μl per minute from atmospheric pressure into the RGA chamber. This flowrate is so small that the system would take hours just to drain the volume in the body of the valve and result in an unusable response time. The bypass flow configuration gives an exceptional response time of less than 0.2 seconds from the tip of the capillary to the RGA chamber. The flexible capillary allows the inlet to be connected to remote locations easily. Capillaries are available in a wide variety of materials and sizes for different applications. The Technical Reference Manual contains guidelines for choosing the diameter and length of custom capillaries.

Two solenoid valves control the gas flows. They can be set in four different combinations, and the Operation section describes the use of each. The entire gas handling system is supervised by a microcontroller, which assures that the valves and pumps are operated correctly.

Mass Spectrometer

A residual gas analyzer (RGA) is mass spectrometer of small physical dimensions whose function is to analyze the gases inside the vacuum chamber. The principle of operation is the same for all instruments: A small fraction of the gas molecules are ionized to create positive ions, and the resulting ions are separated, detected and measured according to their molecular masses. RGA's are widely used to quickly identify the molecules present in a gas, and when properly calibrated, can be used to determine the concentrations or partial pressures of the components of a gas mixture.

The SRS RGA is a mass spectrometer consisting of a quadrupole probe, and an electronics control unit (ECU) which mounts directly on the probe's flange, and contains all the electronics necessary to operate the probe. The computer software communicates only with the spectrometer. The RGA has no direct knowledge that it is present in a QMS system; it simply analyzes what is present at the ionizer.

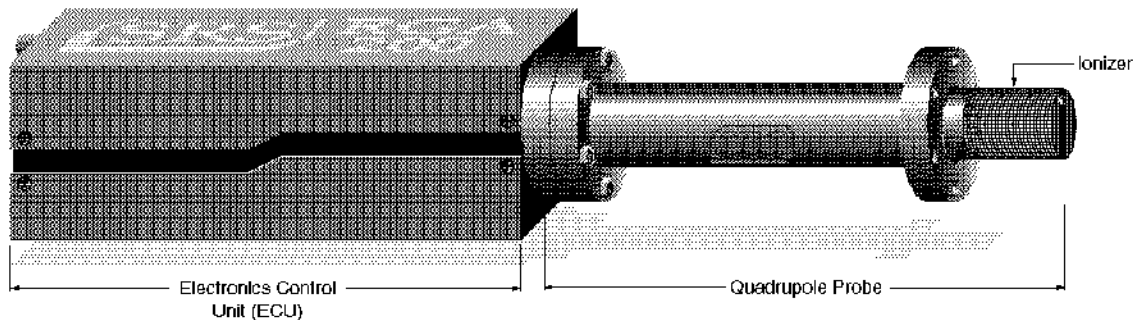

Figure 1-4. Quadrupole Head Components

The probe consists of three parts: the ionizer (electron impact), quadrupole mass filter and ion detector. All of these parts reside in the vacuum space where the gas analysis measurements are made. The ionizer converts the sample gas into an ionized gas that is collected by electric fields into the filter. The quadrupole mass filter contains a precisely controlled high frequency electric field that allows only a narrow mass range to pass through. The ions that pass through the filter are measured by the detector, which is either the standard Faraday cup, or the optional electron multiplier detector.

The ECU is a densely packed box of electronics that attaches directly to the probe's feedthru-flange. It includes several regulated power supplies, a microprocessor, control firmware, and a standard RS232 communications port. The ECU contains a unique, temperature-compensated, logarithmic pico-ammeter that can measure currents from 10^{-15} to 10^{-7} A. This large dynamic range exceeds the physical limitations of RGA's, which can achieve six orders of magnitude dynamic range during partial pressure measurements. The high gain of the electron multiplier allows partial pressures better than 10^{-13} mbar to be detected. RGA's operate in the "constant resolution" or "constant Δm " mode, with $\Delta M_{10\%}$ preset to one amu at the factory. The operating pressure range is from UHV to 10^{-4} mbar. The RGA ionizer will shut down if the total pressure rises above this limit.

Intelligent firmware, built into the RGA Head, completely controls the operation of the instrument, and provides three basic modes of operation of the mass spectrometer:

- Analog scanning

- Histogram scanning
- Single mass measurement

RGA Windows provides fast access to all the RGA functions without the need for any computer programming; however, the instrument can also be programmed directly using the RGA Command Set supported by its serial interface. Consult the RGA Programming chapter of the Technical Reference for information on programming and a complete listing of the RGA Command Set.

Operation

The QMS system is controlled with the four switches on the front panel and the one main power switch. The main power switch activates the cooling fan and provides power to the system. When the main power is on, the RGA is active and can be communicated with through the serial port.

The basic operation of the system is simple:

- Connect the inlet to the gas to be analyzed.
- Start the pumps and gas flow.
- Use the RGA Software to analyze the gas.

The following sections provide all the information to operate the QMS instrument and a primer on mass spectrometry. Chapter 2 provides a general description of the software and Chapter 3 describes specific techniques and procedures. Infrequently, the system will require tuning, which is discussed in a later chapter.

Front Panel Operation

The two pumps and two valves are operated with the four switches on the small panel (see Figure 5). The **Pressure** bar display is the pressure at the inlet port on the instrument front panel. The **Current** bar display is an indication of the current drawn by the turbo pump and is useful as a system diagnostic. Each square in the display is 0.1 A; typically 2-3 bars will be lit. The fault light is an indication that the turbo pump bearings are overheated; this is a severe problem and the system should be shutdown if it ever lights (the turbo pump controller will automatically stop the pump).

A microcontroller supervises the system; it makes sure that the components are turned on in the correct order and prevents improper states. The four switches are **requests** to actuate the associated component. The controller decides whether to perform the request or wait. As an example, the controller waits for the turbo pump to reach full speed before opening the sample valve. The controller sets the light adjacent to each switch to indicate the status of each component:

BLINKING - The requested action is not allowed presently. The action may be performed when other requests are completed or when other switches are changed.

DIM - The action is in progress, *e.g.* pump is reaching full speed.

STEADY - The action is complete: the valve is open, or pump is operating

The four switches can be set in 16 possible combinations; only 8 of these are allowed by the microcontroller. If the user sets a switch in a disallowed arrangement, the light next to that switch will blink. Figure 6 shows the allowed states and the names of each. The microcontroller further limits the transitions between states. All states are related to adjacent states by the changing of one switch. Delays and checks are performed by the microcontroller to assure the system operates properly. These constraints cause the system to only start one component at a time, and they limit the rate of change.

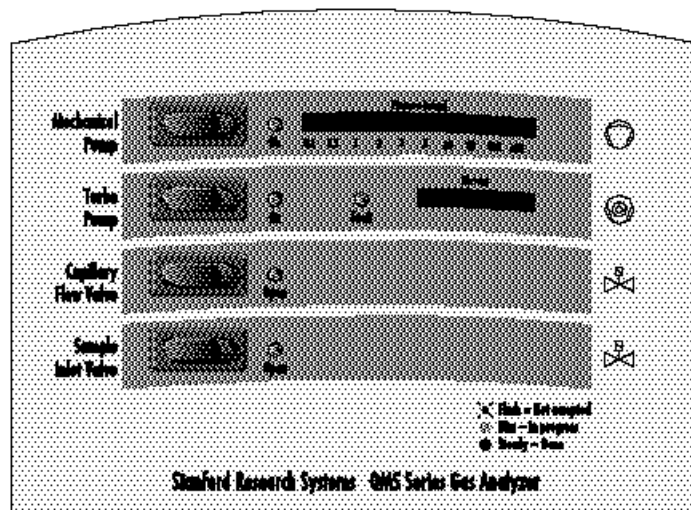

Figure 1-5. Front control panel.

Controller State Diagram

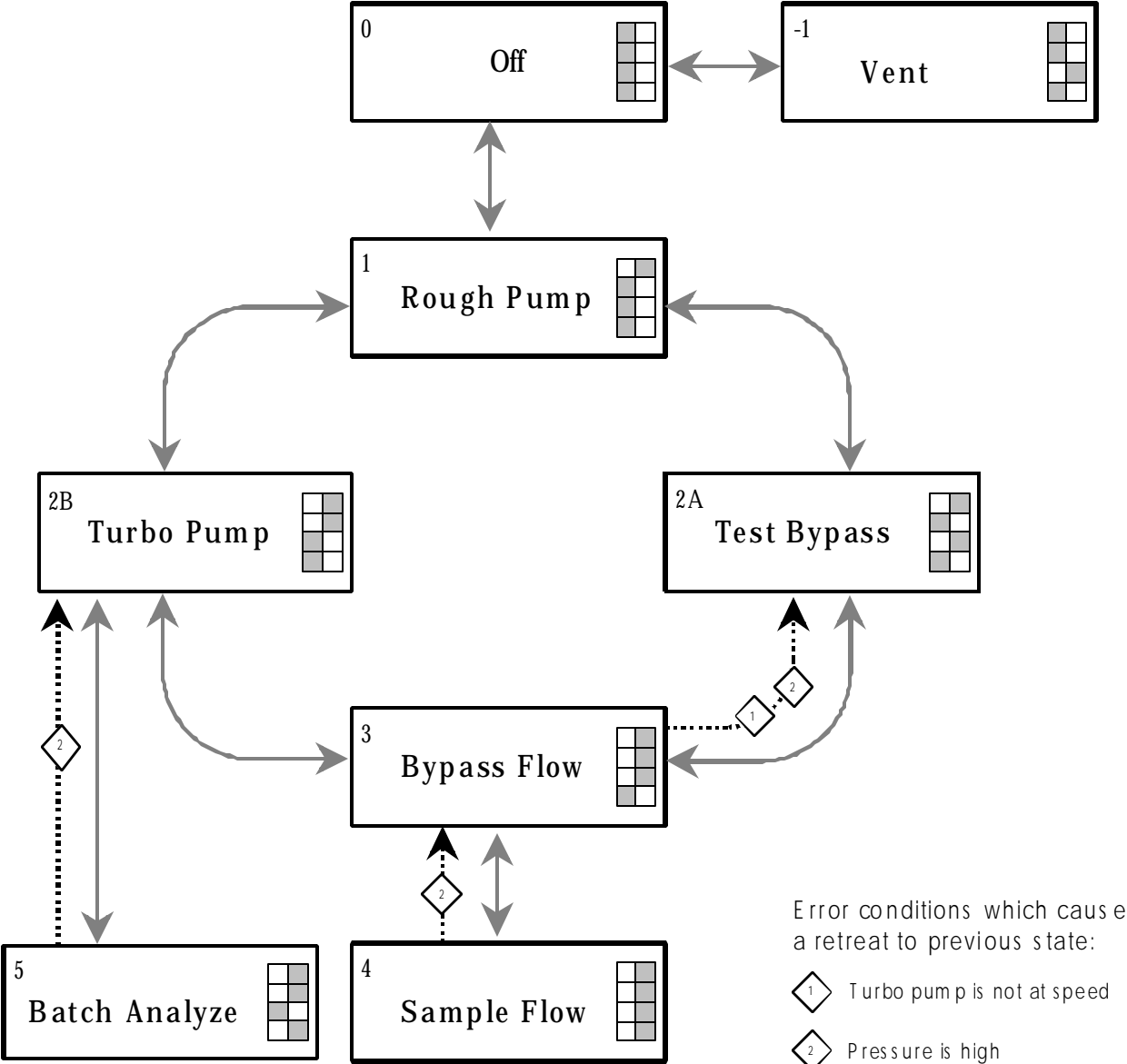

Figure 1-6. Controller state diagram. The gray boxes show which side of the switch is pressed; off is the left.

The microcontroller is inactive for about 5 seconds after main power is turned on. The user cannot turn on any of the system components during this period. If the user does turn on one of the front panel switches during this period, it will be rejected and the adjacent light will blink. To recover from this state, turn off all four switches and begin again. This restriction is related to power failures, which are discussed later in this chapter.

The microcontroller was programmed to support two modes of sampling: continuous and batch. Continuous mode is suited for samples of unlimited volume that change with time. Batch mode is for small volume samples of fixed composition. The QMS system is strongly oriented towards the continuous sampling mode, which makes good use of ability of the instrument to perform high speed continuous measurements. For situations where this flowrate is unacceptable, the batch mode may be useful. The next two sections describe how to setup the instrument to perform these two types of sampling.

Continuous Sample Mode

Continuous sampling requires that the system be set to state 4 in the state diagram (pumps on and all valves open). As the diagram shows, there are two main paths to get from Off to Sample Flow. The preferred path follows the diagram through state 2A. The user should in sequence turn on all four switches in the order Mechanical Pump, Capillary Flow Valve, Turbo Pump, and Sample Inlet Valve. The user does not have to wait for each action to be completed; just toggle the switches in the order you wish the actions to occur. The controller will perform the sequence, following the state diagram through state 2A. When these actions are complete, the system will be sampling and ready to record data. This is the main mode of operation. Other actions are described in the following sections.

Startup Just the Pumps

To prepare the system, but not draw any sample gas, the two pumps can be started. In this state the RGA can be operated, although the mass spectrum will only show the chamber background. This state is useful to prepare the software, test custom programs, and to idle the system (discussed further below). Press just the Mechanical Pump and Turbo Pump switches, which will bring the system to state 2B in Figure 6. The microcontroller will start the diaphragm pump first. After a few seconds, the light will become bright and the turbo pump will start. The turbo pump accelerates to full speed in under 2 minutes. During the acceleration of the pump, the current will reach full scale. Once it reaches full speed, the light will become bright.

Startup the Sample Flow

To start the sample flow from state 2B, the two valves need to be opened. The user can toggle the Capillary Flow Valve and then the Sample Inlet Valve switches to continue to state 4. At state 2B, there is a volume of trapped gas that is at atmospheric pressure between the exit of the capillary and the entrance of the capillary flow valve. This volume must be removed slowly. The solenoid valves are either fully open or fully closed, so the microcontroller follows a pulse program to open the valve. The valve will open momentarily and then close. This will be repeated as many times as necessary to start the capillary flow without stopping the turbo pump. Capillaries with large volumes will require several steps; this will be accompanied by much clicking, which is normal. Once the capillary flow is

established, the sample valve will open, and measurements can be made. When the capillary flow valve is first opened, a pressure pulse will occur in the system that will invariably shutoff the RGA filament. If you were previously making measurements at state 2B, the RGA filament should be turned off while starting the sample flow. Restart the RGA after the sample flow has been established.

An alternative route is to turn off the turbo pump and restart the system by the normal path (0,1,2A,3,4). This avoids the valve pulsing discussed above and is slightly quicker. To use this path, turn off the Turbo Pump switch and wait for the light to go off. Then (in this order) turn on the Capillary Flow Valve, Turbo Pump, and Sample Inlet Valve. As with the previous method, turn off the RGA filament during these steps.

Idle

When samples are not being measured, the system can be idled at two levels. Idle states minimize the load on the pumps, thereby extending their life. The system also can pump out the background more quickly at idle. These statements do not mean the system is not designed to operate continuously; the system will run 24 hours a day.

For short periods, idle the system by closing the Sample Inlet Valve. This lowers the pressure in the high vacuum area of the system and helps to keep the background minimized. Stopping the sample flow when measurements are not being made is most important when gases containing water are being measured. Water permeates into the walls of the vacuum chamber and is only removed slowly. The less exposure to water, the quicker the background will be lowered.

For long periods, idle the system by closing both valves. With the capillary flow closed, the work load of the diaphragm pump is at its lowest, which extends the life of the diaphragms. The turbo pump can also more effectively pump the high vacuum area with both flows stopped.

Shutdown

The diaphragm pump should not be stored under vacuum for long periods. Because of this, different procedures are recommended when the system is shutdown for short or long periods. For short periods simply turn off the main power. For shutdown periods longer than about 30 minutes, it is advisable to vent the system. There are several acceptable methods for venting. All are accomplished by opening the Capillary Flow Valve with all the other switches off (state -1 on the diagram):

- SLOW - While the turbo pump is still coasting to a stop, open the capillary flow valve with the capillary still connected to the inlet. The system will be slowly vented, and the turbo will stop in a few minutes. Once the pressure gauge shows atmospheric pressure, the system is vented.
 - FAST - Wait for the turbo pump to coast to a stop. Remove the capillary and open the capillary flow valve. Useful when filling the system with a dry gas for storage.
 - FASTEST - When the turbo pump is still coasting to a stop, remove the capillary and open the capillary flow valve. This instantly raises the system pressure to atmospheric. Unlike older devices, the turbo pump will not be destroyed. Still, this is the least recommended path.
- NOTE: Do not vent the system to pressures above atmospheric. If the capillary is connected to a gas at pressures above 1 bar, monitor the pressure during venting. Stop just as the pressure reaches atmospheric.

If the diaphragm pump is inadvertently stored under vacuum for extended periods, the internal pressures will reach a state that prevents the pump from starting. If this has happened the user will hear a relay click but the diaphragm pump will not start. This locked state is cured by venting the system; the diaphragm pump will then start up. Storage under vacuum also temporarily degrades the ultimate pressure of the diaphragm pump. Once the pump is operating, the performance will return over several hours.

Overpressure Protection

The RGA cannot drive the ionizer filament if the pressure in the chamber is too high. When the RGA senses high pressure (via the power required to drive the filament), it will shut off the filament. This is a protection measure, and should not be relied on to turn off the filament. When shutting down the system, turn off the QMS filament before the turbo pump is turned off.

Batch Analyze Mode

This state is a special mode designed for advanced users and requires constructing a custom inlet apparatus. You can ignore this section and mode, unless you specifically require the batch feature. This mode requires that the inlet pressure of the QMS is less than 5 mbar. If this condition is satisfied, the microcontroller will allow the Sample Inlet Valve to be opened. At state 5, there is no bypass flow and a small flow is drawn from the sample. Using this mode requires that the capillary be replaced with a custom apparatus (provided by user) which allows the sample to be admitted into a small reservoir that will hold the sample during measurement. After the sample is admitted at atmospheric pressure, the reservoir is closed off and pumped down to less than 5 mbar. An external pump can perform this, or it is possible to use the QMS itself to pump the reservoir, by momentarily using state 3 to pump down to vacuum and then changing back to state 2B. When designing experiments with this mode, users need to be aware that the internal volume of the QMS is about 50 ml (volume between two valves and inlet port). Flush cycles will be required to remove gas from previous samples.

Microcontroller Error Checks

The microcontroller is programmed to prevent the system from restarting after a power failure. If the Mechanical Pump switch is turned on before line power is applied, the controller will halt and prevent further action from taking place. It will stay halted until the Mechanical Pump switch is turned off, which resets the system. When the system is halted after a power failure, you will see that the diaphragm pump switch is on and the light is flashing. Under normal circumstances, the diaphragm pump switch is never rejected, and therefore the light would be either dim or steady. Only a power failure can cause the diaphragm pump switch to be rejected.

The microcontroller performs several error checks to assure correct operation:

- From 2B→3: The capillary flow will not be started until the turbo pump is at speed. If the pressure at the inlet to the QMS is above 5 mbar, the microcontroller opens the capillary flow in short pulses. The valve is pulsed repeatedly until the pressure is below the setpoint.
- At 3: If the turbo pump begins to slow down, it will be turned off and the system will retreat to state 2A. The likely cause of a sudden slowdown of the pump is excessive pressure. The system will wait at 2A until the pressure is okay and then try to restart the turbo pump.
- At 3: If the pressure is above 5 mbar, the capillary flow valve is shut off and the system retreats to state 2A. It will stay there until the pressure is satisfactory.
- At 4 or 5: If the intermediate pressure exceeds 5 mbar, the sample valve will be closed. This action prevents excessive pressures in the RGA chamber.

The microcontroller does not time out nor latch error conditions. This means that if the switches are set to sample gas (State 4), the microcontroller will continuously try to reach that state.

Operating Modes of the Spectrometer

The RGA is a mass spectrometer that analyzes residual gases by ionizing some of the gas molecules (positive ions), separating the resulting ions according to their respective masses and measuring the ion currents at each mass. Partial pressure measurements are determined with the help of previously calculated sensitivity (i.e. calibration) factors by reference to the abundance of the individual mass numbers attributed to each gas type.

During analysis, positive ions are formed within the ionizer and directed towards the spectrometer's **quadrupole mass-filter**. The mass filter determines which ions reach the detector at any given time. It is operated by a combination of RF and DC voltages and the filtering action is based on the mass-to-charge dependency of the ion trajectories on the RF and DC fields. The magnitude and frequency of the RF determine the **mass-to-charge ratio** of the ions that can pass through the filter without striking the rods (i.e. with stable oscillations). The RF/DC ratio determines the filter selectivity. Ions that successfully pass through the filter are focused towards the **detector** and the resulting analog current is measured by the very sensitive electrometer.

A brief note on Mass Units in Mass Spectrometry:

Since molecules are so small, it is convenient to define a special type of mass units to express the masses of individual ions. The **atomic mass unit, amu**, defined as 1/12 of the mass of a single carbon atom, isotope 12 (i.e. ^{12}C), is the unit of molecular mass most commonly used in mass spectrometry (**1 amu = 1.660 540 x 10⁻²⁷ kg**). To a very accurate approximation, the mass of a molecule in atomic mass units (amu) is equal to its **mass number M**, defined as the sum of the number of protons and neutrons in the molecule.

Mass spectrometers do not actually measure the molecular mass directly, but rather the mass-to-charge ratio of the ions. The mass-to-charge ratio, **M/Q**, is defined as the ratio of the mass number M of the ion to its charge Q, measured in units of the electron charge e^- . For example: doubly charged ions of argon isotope 36 ($^{36}\text{Ar}^{2+}$) and singly charged ions of water, $^1\text{H}_2\ ^{16}\text{O}^{1+}$, have **M/Q = 18**, and cannot be differentiated from each other with most mass spectrometers.

For singly charged ions, the mass to charge ratio is numerically equal to the mass of the ion in atomic mass units (amu).

RGA users often use the term “mass of an ion” when they really mean the mass-to-charge ratio. This convenient way of speaking is strictly valid for singly charged ions only.

The RGA as a Mass Spectrometer

The RGA can perform both analog and histogram scans over its entire mass range. Residual gas analysis relies on the interpretation of the spectral data generated by these two modes to completely characterize, both qualitatively and quantitatively, a vacuum environment.

RGA Windows uses the two modes to generate the data for the Analog and Histogram Scan Modes.

Analog scanning is the most basic operation of the RGA as a quadrupole mass spectrometer. During analog scanning the quadrupole mass spectrometer is stepped at fixed mass increments through a pre-specified mass-range. The ion current is measured after each mass-increment step and transmitted to the host computer over RS232. Analog scanning allows the detection of fractional masses and provides the only direct view of the peak shapes and resolution of the instrument.

A **Histogram (Bar Mode) Scan** consists of a succession of individual peak-height measurements over a pre-specified mass range. A single value is used to represent the peak heights at each integer mass within the range. The peak height measurements are made with the **Peak-locking** scanning procedure described in the next section. Histogram scanning is one of the most commonly used modes of operation for the RGA. Its two main advantages are a faster scan rate than analog scans, and a reduced amount of data being exchanged during the scan.

The RGA as a Single Gas Monitor

The RGA can measure individual peak heights at any integer mass within its mass range.

This mode of operation is used to generate data for leak testing measurements, and to track changes in the concentrations of several different components of a mixture as a function of time. The outputs provided by a set of single mass measurements are often used in process control programs to control alarms, analog and digital outputs, and relays.

RGA Windows uses this mode to generate its data for the Table, Pressure vs. time, Annunciator and Leak Detection modes.

Peak Locking procedure: During a Single Mass Measurement the RGA performs a Miniscan around the mass requested, and the **maximum current value** measured is **sent out over RS232**. The scanning procedure, referred to as **Peak-Locking**, is designed to measure peak currents for individual masses in a mass spectrum without being affected by drifts in the mass-axis calibration. The Miniscan covers a 0.6 amu range centered at the mass requested, and selects the maximum current from 7 individual measurements performed at 0.1 amu mass increments.

The RGA as a Total Pressure Gauge

The RGA can measure total pressures.

The RGA might be thought of as a Total Pressure Ionization gauge with a mass analyzer interposed between the ionizer and the detector. Thus, by disabling the mass-filtering action of the analyzer section, it is possible to detect the total ion current from the ionizer and perform total pressure measurements. A total pressure sensitivity factor, stored in the non-volatile memory of the RGA, is used by RGA Windows to convert the total current measurements into total pressures.

Important: The sensitivity factor for the total pressure measurements is highly mass dependent. Some additional mass discrimination takes place in the filter that results in the mass dependence of the RGA readings being different from that of the Bayard Alpert gauges. **Expect to see deviations between the two gauges as the composition of the residual gas changes.**

Mass Spectrometry Basics

The RGA can perform both qualitative and quantitative analysis of the gases in a vacuum system. Obtaining spectra with the RGA is very simple. Interpreting the spectra, that is, understanding what the spectra is trying to tell you about your vacuum system requires some work. The following sections will introduce some basic concepts of Spectral Analysis emphasizing the main aspects of Residual Gas Analysis. For additional information on the subject of Residual Gas Analysis refer to:

J. Drinkwine and D. Lichtman, Partial Pressure Analyzers and Analysis, AVS Monograph Series published by the Education Committee of the American Vacuum Society

Basford et. al., J. Vac. Sci. Technol. A 11(3) (1993) A22-40 "Recommended Practice for the Calibration of Mass Spectrometers for Partial Pressure Analysis. Update to AVS Standard 2.3".

For information on multiple linear regression analysis consult:

William H. Press, et. al., 1992, Numerical Recipes in C, The Art of Scientific Computing, Second Edition, Cambridge Univ. Press, section 15.4, page 671.

Bevington, P.R., 1969, Data Reduction and Error Analysis for the Physical Sciences, New York, McGraw-Hill, Chapters 8-9.

How Mass Spectra are Interpreted

A mass spectrum, taken in a real system, will almost always contain signals from a mixture of various gases. Careful and complete interpretation of the spectrum (i.e. a complete spectral analysis) should reveal the identity, as well as the concentrations, of the various components which have produced the spectrum.

The first step in the spectral analysis process is to correctly identify the mass-to-charge ratio of all the peaks in the mass spectrum. A well calibrated mass scale is essential to this task. See the RGA Tuning Chapter for a detailed description of the mass scale calibration procedure.

Once all the peaks have been labeled, the next step is to identify the residual gases that have produced the spectrum. A knowledge of the recent history of your system may provide very valuable clues as to the possible gases that may be residuals in the vacuum chamber. A familiarity with the standard spectra of commonly expected gases will generally help to determine the major and minor components in the system. Any peak in the spectrum may consist of contributions from molecular ions and/or fragment ions, or multiply ionized species. **The qualitative spectral analysis is completed when all the peaks in the spectrum have been "uniquely assigned" to the components of a gas mixture, in complete agreement with the known fragmentation patterns of the components.**

In cases where only the major components are of interest, some of the minor peaks of the spectrum will remain unassigned. If only a few species are being monitored, only the peaks corresponding to the substances of interest need to be assigned and monitored.

Notes on Fragmentation Patterns: The electron impact type of ionizer used in modern RGA's almost always causes more than one kind of ion to be produced from a single type of gas molecule. Multiple ionization, molecular fragmentation and changes in the isotopic composition of the molecule are responsible for the effect. All ions formed contribute to the mass spectrum of the molecule and define its **fragmentation pattern**. The identification and interpretation of mass spectra must begin with a knowledge and understanding of the standard fragment patterns of atoms and molecules that may exist in the system. The standard fragment patterns of most molecules commonly encountered in residual gas analysis are well established and listed in the general RGA Literature. A very complete library can also be accessed through the Library Search Utility of the RGA Windows software. The Gas Library has a standard text file format, and can easily be read, extended or modified by the user to fit his individual needs.

Partial Pressure Measurement

Once the different components of a mixture have been identified it is possible to use the RGA to obtain quantitative values for the various partial pressures. This section describes the basic steps needed to perform quantitative measurements with the instrument. The formalism presented assumes multiple gas analysis, but is equally valid for single gas measurements. Please consult the suggested references for details and examples of these procedures.

The entire mathematical formalism used to derive the partial pressures of a mixture based on a single mass spectrum is based on one assumption:

The total spectrum is a linear combination of the spectra of the different species that are present in the mixture. In other words, the total spectrum is equal to the sum of the individual peaks that would be observed if each constituent were alone in the system.

In mathematical terms, the assumption stated above can be written as the following linear equation:

$$H_M = \sum_g h_{Mg} \quad (1)$$

where:

g is an integer variable that represents the gases present (*i.e.* assign an integer to each gas starting with one)

M is an integer variable that represents the mass numbers for the entire mass range of the spectrum.

H_M = total peak height (amps) of the spectrum at mass number M .

h_{Mg} = peak height contribution (amps) from gas g at mass M .

h_{Mg} is related to the fragmentation pattern, the RGA's sensitivity and the partial pressure of gas g by the equation:

$$h_{Mg} = \alpha_{Mg} S_g P_g \quad (2)$$

where:

α_{Mg} = Fragmentation factor of gas g at mass M : Ratio of ion signal at mass M to the ion signal at the principal mass peak for gas g .

S_g = RGA's partial pressure sensitivity factor for gas g , in amp/Torr (see Partial Pressure Sensitivity Factor below)

P_g = Partial pressure of gas g in the system.

Equations (1) and (2) are combined to obtain the system of equations:

$$H_M = \sum_g (S_g \alpha_{Mg}) P_g \quad (3)$$

Since all gases have more than one peak in their fragmentation pattern, the number of peaks (M) in a real spectrum is generally larger than the number of gases (g). As a result, the system of equations (3) usually has more equations than unknowns. This situation is sometimes simplified eliminating some of the extra equations; however, the best results are obtained using all the equations and a multiple linear regression procedure to calculate the best possible fit to the data.

Obviously, accurate results can only be obtained if the constants α_{Mg} and S_g are well known for the RGA being used.

Note: The Analyze Utility of RGA Windows uses a multiple linear regression algorithm, as mentioned above, to automatically calculate the composition of a "typical residual gas environment" at the end of any 1-50 amu spectral scan. Please see the RGA On-Line Help files for details.

Standard fragmentation patterns (for example, the fragmentation patterns included in the RGA Library of RGA Windows) can be used as a source of α_{Mg} values in moderately quantitative determinations. However, when very precise numbers are desired, one should obtain the appropriate fragment patterns by introducing pure gas into the RGA being used. The fragment patterns must be obtained under the same conditions that will be used during regular spectral analysis since they depend on many instrumental parameters, including: electron energy, emission current, ionizer design, mass filter settings, detector type, multiplier gain, etc. The principal mass peak of a fragmentation pattern is simply the most intense peak of the spectrum, and the intensity of all the other peaks in the pattern are normalized to its height for the calculation of fragmentation factors. **Note that by our definition the α_{Mg} value for the principal mass peak of any gas is equal to one.** Principal mass peaks are used in the calculation of the sensitivity of the RGA to different gases as shown below.

Partial Pressure Sensitivity Factors

The partial pressure sensitivity of the RGA to a gas g , S_g , is defined as the ratio of the change ($H-H_0$) in principal mass peak height to the corresponding change ($P-P_0$) in total pressure due to a change in partial pressure of the particular gas species. H_0 and P_0 are background values.

$$S_g = (H-H_0) / (P-P_0)$$

The units of S_g are of ion current per unit pressure (amp/Torr, for example).

The sensitivity of the RGA varies with different gases, changes with time due to aging of the head, and is a strong function of the operating conditions of the instrument. Careful quantitative analysis requires that the sensitivity factor, S_g , be determined for every gas which may be a component gas in the system being analyzed. The sensitivity factors must be obtained under the same operating conditions that will be used during general partial pressure analysis since they depend on many instrumental parameters, including: ionization energy, emission current, mass filter setting, type of detector, etc.

In order to separate the gain of the electron multiplier from the intrinsic sensitivity of the RGA head, the sensitivity factors of the RGA are defined for Faraday Cup detection. A separate Electron Multiplier Gain Factor, is used to correct the ion signals when the electron multiplier is turned on. See the Sensitivity and Electron Multiplier Tuning sections of the RGA Tuning Chapter for details.

The basic procedure for determining the sensitivity of a particular gas in the RGA is the following:

- Introduce the pure gas into the vacuum system, at a known or calculable pressure (typically around 10^{-6} Torr).
- Measure the output signal from the RGA for the principal mass peak of that gas using the Faraday cup detector.
- The ratio of this output signal to the pressure of the gas is the sensitivity factor, S_g .

During these measurements it is very important to insure that the partial pressures of all other gases in the system are small enough so that they may be neglected. The sensitivity factors calculated can only be applied to situations where the RGA is used with the same operating parameters. See the Sensitivity Tuning section in the RGA Tuning chapter of this manual for more details on this calibration procedure.

A **total pressure sensitivity factor** is also needed by the RGA to convert the ion currents obtained during total pressure measurements into total pressures. Total pressure sensitivity factors vary with different gases and share many of the properties of the partial pressure factors. They are determined by a procedure identical to the one described above, but with the partial pressure measurements replaced by total pressure measurements.

The underlying assumption when using sensitivity factors in quantitative calculations is that there is a linear relation between the partial pressure and the corresponding RGA signals of the gases. Deviations from linearity are to be expected above 10^{-5} Torr due to space charge effects in the ionizer and ion-neutral scattering interactions in the filter. A more thorough check of the RGA's sensitivity involves measuring the RGA signals over several orders of magnitude of partial pressure to determine the range over which a linear relationship exists. The sensitivity factor for the gas is calculated as the slope of the "signal vs. partial pressure" response over the linear range.

RGA Windows uses two sensitivity factors stored in the non-volatile memory of the RGA Head. The sensitivity factors, one for total pressure and one for partial pressure, are used as conversion factors between the ion currents received from the head and the pressure units selected by the user. The sensitivity factors are measured with the Faraday Cup detector and can be updated or changed very easily by using the Sensitivity Tuning command in the Head menu. A separate Electron Multiplier Gain Factor, stored in the non-volatile memory of the RGA Head, is used to correct the ion signals for the gain of the electron multiplier. The gain of the electron multiplier is highly mass dependent and defined relative to the corresponding FC signal. An automatic Electron Multiplier Gain Adjustment command,

built into the program, can adjust the CDEM voltage for any gain between 10 and 10^6 . Consult the RGA On-Line Help Files for details on the automated tuning procedures built into the RGA Windows program. Also see the Sensitivity and Electron Multiplier Tuning sections of the RGA Tuning Chapter for more general information.

The Table mode of RGA Windows offers scaling factors for all of its channels eliminating the limitations imposed by the single sensitivity factor on multiple partial pressure calculations. For example, the scaling factors can be used to display correct partial pressure for all the species in a table if the ratios between the partial pressure sensitivities of the different components are known and only principal mass peaks are used to monitor them. The scaling factors can also be adjusted to correct against the mass discrimination of the electron multiplier's gain.

Important: Following current industry standards, the partial pressure sensitivity factor stored at the factory corresponds to N_2 measured at 28 amu with $\Delta m_{10\%}=1$ amu, default ionizer settings and Faraday Cup Detection.

Single gas measurement example:

Monitoring the concentrations of one or few components in a system is easy in the absence of severe spectral interference.

Suppose a system where argon is measured at 40 amu (principal mass), in the absence of any other gases that contribute a signal at that mass value. The sensitivity to argon was previously measured at $S_{Ar}=10^{-4}$ amps/Torr, and the electron multiplier is biased and its gain at mass 40 was previously measured at $g_{CDEM}=1.02 \cdot 10^3$ relative to the FC signal.

The partial pressure of argon, P_{Ar} , is easily calculated measuring the intensity (*i.e.* peak height) of the ion current at mass 40, I_{40} .

$$P_{Ar} = I_{40} / (g_{CDEM} \cdot S_{Ar}), \text{ units of Torr} \quad (4)$$

The peak value, I_{40} , can be extracted from a spectral scan or measured directly using the single mass measurement mode of the RGA. For example, a 10^{-9} amp peak value corresponds to 9.8×10^{-9} Torr of Ar. Note that equation (4) is a particular case of equation (3), and that the fragmentation factor for the principal peak of Ar is one by definition.

Chapter 2. Windows Software

The QMS system contains a mass spectrometer that belongs to a class of spectrometers commonly referred to as *residual gas analyzers or RGA*. RGAs are low resolution, low mass range, quadrupole spectrometers. The SRS spectrometer is used both as a stand-alone RGA and in the PPR and QMS systems. The same software package is used to operate all three instruments. The description in this chapter refers to the spectrometer as *RGA*.

More information about the RGA program can be found in the On-Line Help files provided on the program CD. The RGA help system includes current and detailed description of all the features, procedures, and commands available in the program.

In This Chapter

Overview	2-3
Program Structure	2-3
RGA Files	2-3
RGA files (.rga)	2-3
RGA Scan log files (.ana .hst .tbl)	2-3
RGA ASCII Data files (.txt)	2-4
RGA Graph Metafiles (.wmf)	2-4
System Requirements	2-4
Getting Started	2-4
Starting the RGA Software	2-5
Connecting to a Head	2-5
Shutting Down the RGA System	2-5
Features and Operation	2-6
The RGA Window	2-6
Multiple Head Operation	2-6
Display Modes	2-6
Analog (Mode Menu)	2-7
Histogram (Mode Menu)	2-7
Table (Mode Menu)	2-7
P vs. T (Mode Menu)	2-8
Leak Test (Mode Menu)	2-9
Annunciator (Mode Menu)	2-9
Library (Mode Menu)	2-10
Data Acquisition	2-10
Scan Data Logging	2-11
Graph Management	2-11
Head Management	2-12
Sensitivity Factors	2-12
Spectrum Analysis	2-12
Background Data	2-13
RGA Head and Scan Parameters	2-13
Changing Scanning Parameters	2-13
Changing Head Parameters	2-14
Changing Scan Trigger Rates	2-14
Scanning With The Filament Off	2-15
Display Modes	2-15
Changing Display Modes	2-16

Running in Split Display Mode.....	2-16
Manual Scaling of Graphs.....	2-16
Using Scan Data as Background.....	2-16
General Utilities.....	2-17
Using the Data Cursors.....	2-17
Scheduled Saving of Data.....	2-18
Logging Scans.....	2-18
Viewing Scans.....	2-18
Browsing Through the Gas Library.....	2-19
Analyzing the Mass Spectrum.....	2-19
Spectrum Analysis description.....	2-19
Analysis Procedure.....	2-20
Pressure Reduction.....	2-20
Head Calibration and Security.....	2-20
Tuning the RGA Sensitivity.....	2-20
Adjusting the CEM Gain.....	2-21
Peak Tuning the RGA Head.....	2-22
Securing the RGA Head.....	2-23
RGA On-line Help.....	2-23
Help Search.....	2-23
Help Index.....	2-23
Commonly Asked Questions.....	2-24
Sample Scans.....	2-24

Overview

Program Structure

The RGA program is a fully interactive Windows program capable of managing several RGA Heads simultaneously. Fully interactive means that you can double-click on any graph object and the program responds by executing a specific command such as editing the color of a data line.

RGA was designed to handle data acquisition from multiple heads simultaneously by assigning one head for each window and by making all the windows independent from each other. Each window can be thought of as a separate RGA Head control & display file. This file, called an RGA file, stores all the information regarding the graph parameters, scan parameters, some head parameters, what port the head was connected to, etc.

It is not necessary for an RGA file window to be connected to a specific head at all times. You could, for example, open a file just to browse through a few dozen scans that were done overnight. You can also copy the graph to the clipboard so you can paste it into a word processor.

Once an RGA window is connected to a Head, you can start scanning (acquiring data) in any of the display modes available. When you are done scanning, you can either close the file which will automatically disconnect you from the head, or you can issue a disconnect command and keep the file open for further data analysis. You can even connect the same window to a different head on another RS232 port.

RGA Files

The RGA program is capable of saving files in a variety of formats. This section describes all the file formats and their different uses.

RGA files (.rga)

RGA files are the main files used in the RGA program. They are binary files that contain scan data with all the information on the graph parameters, scan parameters, scan schedule parameters, etc. When the RGA file is saved, it saves the last scan data along with all the setup parameters of that window. When the file is open again, it creates a window that has the same parameters as when it was saved including the data from the last scan.

RGA Scan log files (.ana .hst .tbl)

RGA scan log files are binary files that contain mostly raw data from multiple scans acquired over a period of time. These files do not have any of the RGA file setup parameters in them in order to save disk space. They contain the time and date for each scan and the minimum scan setup information to reconstruct the scan data graph. These log files are available for the Analog, Histogram, and Table modes.

RGA ASCII Data files (.txt)

The RGA program can save the last scan data in an ASCII format that is easily read by spreadsheet programs for data analysis. The file header contains the scan setup information followed by the scan data. The RGA program does not read these ASCII file, it only writes them.

RGA Graph Metafiles (.wmf)

RGA can also save the active graph as a Windows Metafile. Windows Metafiles are easily read by many word processing, page layout, and graphic programs. The graphs can be easily saved by RGA and then recalled by any of these programs for documentation and presentations.

System Requirements

The RGA program system requirements vary depending on the performance required of the RGA system and on how many heads are connected and run simultaneously. The RGA Head can scan data at different scan speeds that effect noise floor and averaging. If you choose to scan at the fastest speed and want the RGA program to "keep up" with the head, then a faster computer, i/o card, and graphics card might be required.

Following, is the **minimum** recommended system to run a SINGLE head system:

- IBM PC compatible machine with 64 Mbytes of RAM
- Mouse or equivalent pointing device
- Serial port and DB-9 to DB-9 RS232 cable, or serial to USB adapter if your computer does not have a serial port
- 100 Mbytes of free hard disk spaces (for RGA installation and runtime use) and CD drive (for the installation disk)
- Super VGA graphics card running in 800x600, 1024x768, 1280x1024, 1600x1280 with minimum 256 color mode
- A sound card if the audio features are needed
- Microsoft Windows 98 or later

Getting Started

The following sections describe how to launch the RGA program and start acquiring data from the RGA Head.

Note: For detailed information and command description of the RGA program please refer to the RGA On-Line Help files provided on the program CD. The RGA help system includes current and detailed description of all the features, procedures and commands available in the program.

Starting the RGA Software

To start the RGA software simply double-click on the RGA icon in the "SRS RGA" program group created by the RGA installation program. You may also type the full path name of the RGA program in the Run command from the Program manager.

The program also accepts a file on the command line. If a filename is specified, the program will open that file at startup. You can open the program by double clicking on any file with the .rga extension. You can open any .rga file from windows explorer by dragging it to the running program.

You can only run one copy of RGA at the same time. If you attempt to start another copy of RGA while it is already running, the existing copy is activated and brought to the front of the screen.

Connecting to a Head

Connecting to an RGA Head requires an available RS232 port on your PC and a full DB9-DB9 RS232 cable. To connect to an RGA Head do the following:

1. Connect the RS232 cable to the DB9 connector on the Head labeled "RS232/DCE/28.8k.Baud".
2. Connect the other end of the cable to the RS232 port on the PC side.
3. Turn On the RGA Head.
4. Start MS Windows and the RGA Program.
5. Select Connector List Setup from the Head menu.
6. Select the port to which the RGA head is connected.
7. Press the Connect button.

The connection is made when the connector icon turns green and the status of the instrument shows string "connected". After you close the Connector List Dialog, the toolbar GO button turns green, and the Scan and Head menu commands get enabled.

Shutting Down the RGA System

If the user simply exits the program, the RGA will be left in its current state. Disconnecting from the RGA will also leave the RGA setup unchanged. This means that the filament and CEM can remain on when the program is quit. This can be useful in some situations.

When the RGA is not in use, the filament and CEM should be turned off. This will extend their life. To accomplish this remember to explicitly turn off the filament and CEM before leaving the software. The entire ECU can be left on when the RGA is not in use. At idle the electronics draw minimal power.

The recommended shut-down procedure is:

1. Stop the scan if there is one in progress using the Stop Now command in the Scan menu.
2. Turn off the filament and CEM.
3. Save the RGA file you have been working on, using the Save or Save As command in the File menu.
4. Terminate the RGA program using the Exit command in the File menu.
5. Turn off the RGA Head.

Features and Operation

The RGA Window

The RGA window represents one SRS RGA Head operating in a specific display and scan mode. The RGA window does not need to be connected to a head at all times. It can be used to print graphs or to review some old scan logs. You may size, tile, minimize, or cascade several RGA windows together even while scanning.

When an RGA window is sized, all the graph objects in it are also sized down or up. For optimum viewing of a graph, maximize the RGA program window, and maximize the RGA file you wish to view.

Multiple Head Operation

The RGA program can monitor several SRS RGA Heads simultaneously. Each RGA window represents a separate RGA Head that is controlled independently from any other window/head combination.

To connect an RGA Head to an RGA window, use the RS232 Setup command to assign a port (that you know is attached to an RGA Head) to that window. The operation of the RGA program is unchanged whether you have one or several heads connected and scanning. The only difference you might see is a slowdown in display update, and that is dependent on the computer hardware you use.

Display Modes

There are seven distinct display modes in RGA along with split modes that consist of combinations of these modes.

Following are the seven distinct modes:

Analog (Mode Menu)

Analog mode is the spectrum analysis mode common to all Residual Gas Analyzers. The X-Axis represents the mass range chosen in the Mass Spec Parameters menu. The Y-Axis represents the ion current amplitudes of every mass increment measured.

Select the Schedule menu to set the scan trigger timing. Once the scan is in progress, the AutoScale menu may be used to scale the data.

The Analog Trace parameters such as color and width may be changed by either double clicking on a data point directly (if data is present) or by using the Traces command from the Graph menu.

In Analog mode the RGA Head scans from the start to the stop mass using the Points Per AMU variable specified in the Scan Parameters dialog box (Scan drop-down menu or click the Mass Spec Scan Parameters menu button on the toolbar). This Points Per AMU variable is used to determine the mass increments between data points. The time to acquire each partial pressure depends on the scan speed selected (the plotting speed depends on the user's computer).

The control view bar may be used to zoom, scroll and view all data, even if a scan in progress.

Histogram (Mode Menu)

Histogram mode displays the individual mass amplitudes for the selected scan range. In this mode the RGA head performs a peak-lock for each mass and calculates one amplitude per mass. This peak is then plotted as a bar at the appropriate mass. The X-Axis represents the mass range chosen in the Scan Parameters menu. The Y-Axis represents the ion current amplitudes of every mass measured. A mass index indicator is located at the left of the X-Axis. The index displays the mass that is currently being updated (assuming a live scan is in progress).

Use the Schedule command from the Scan menu to set the scan trigger timing. Once the scan is in progress, the AutoScale command (Graph menu) menu may be used to scale the data.

The Histogram Traces (bars) colors may be changed by either double clicking on the bars or selecting the Traces command from the Graph menu.

In Histogram mode the RGA Head scans from the start to the stop mass running 7 measurements per AMU. After performing a peak lock on each 7 points it then sends the maximum value to the RGA program. This results in one point per mass being plotted as a bar graph. The time to acquire each partial pressure depends on the scan speed selected (the plotting speed depends on the user's computer).

The control view bar may be used to zoom, scroll and view all data, even if a scan in progress.

Table (Mode Menu)

Table mode presents a tabular form readout of preselected gases along with alarm level warnings. The gas masses, names, and parameters can be set using the Scan Parameters command (Scan menu). The scan parameter dialog also can be evoked by clicking on the Mass

Spec Scan Parameters menu button on the toolbar

Table entries can be configured independently from each other. Some entries can use the Channel Electron Multiplier (CEM), while others can have different scan speeds with the CEM off.

The alarm control and level settings can be edited by either double-clicking on the Alarm text of the desired table entry, or by clicking on the 'Alarm X' (where X is the channel number) button for the appropriate table entry in the Table Parameters dialog box.

Select the Schedule command (Scan menu) to set the scan trigger timing and frequency. The Table Traces may be edited by either double-clicking on the text directly (except for the Alarm text), or by selecting the Traces command (Graph menu).

Important: Table mode, P vs. T mode, and Annunciator mode share the same table scan parameters, alarm parameters, and graph trace colors.

The data acquisition method for the table scan will vary depending on the display mode selected:

In Table mode or Table mode split with P vs. T mode, each table entry value (partial pressure) is acquired directly from the RGA head by individually querying the partial pressure for the appropriate mass. This is done for all the selected masses using the present scan schedule as a trigger. The time to acquire each partial pressure depends on the scan speed selected for that mass (the plotting speed depends on the user's computer).

In Table mode split with Analog or Histogram mode, the Table entry values are extracted from the Analog or Histogram spectrum. No individual mass query is performed. If a Table mass lies outside the Analog or Histogram mass range, its partial pressure will show a zero value with the alarm indicating the appropriate zero value warning. A table entry can be easily disabled using the Table Parameters dialog box.

P vs. T (Mode Menu)

Pressure versus Time mode is a scroll graph of up to ten gas masses in the same plot. The graph scrolls to the left as the data fills the screen and the old data is saved in a history buffer for review at any time. The gas masses, names, and parameters can be set using the Scan Parameters command from the Scan menu.

P vs. T entries can be configured independently from each other. Some entries can use the Channel Electron Multiplier (CEM) while others can have different scan speeds with the CEM off. When this mode is split with Table mode, the result is a wealth of information on the selected gases behavior. The Schedule command (Scan menu) may be used to set the scan trigger timing and frequency. The P vs. T Traces may be edited by either double clicking on them directly, or by selecting the Traces menu.

The control view bar may be used to zoom, scroll and view all data, even if a scan in progress. Note that the Table mode, P vs. T mode, and Annunciator modes share the same table scan

parameters, alarm parameters, and graph trace colors.

The data acquisition method for the P vs. T scan will vary depending on the display mode selected:

In P vs. T mode or Table mode split with P vs. T mode, each table entry value (partial pressure) is acquired directly from the RGA head by individually querying the partial pressure for the appropriate mass. This is done for all the selected masses using the present scan schedule as a trigger.

In P vs. T mode split with Analog or Histogram mode, the P vs. T entry values are extracted from the Analog or Histogram spectrum. No individual mass query is performed. If a P vs. T mass lies outside the Analog or Histogram mass range, its partial pressure will show a zero value. A table entry can be easily disabled using the Table Parameters dialog box.

Leak Test (Mode Menu)

Leak Test mode provides the most effective way to study the behavior of a single gas. This mode provides a scroll graph that monitors the gas trend over a period of time, an instantaneous partial pressure readout, a bar meter, and an Alarm message. An Audible beep with a pitch proportional to the partial pressure is also available if a sound card is installed. If the beep is disabled, an Audio message can be enabled to reflect the status of the Alarm levels.

The gas mass, name, and scan parameters may be configured from the Scan Parameters command (Scan menu). The Leak Trace, bar meter color, and text readout color can be edited by double clicking on them directly (if data is present) or by selecting the Traces command from the Graph menu. Only one color can be selected for all data objects. The Schedule command (Scan menu) may be used to set the scan trigger frequency. The scan parameter dialog also can be evoked by clicking on the tool button in the toolbar.

In Leak Test mode, the partial pressure for the specified gas is acquired by querying the RGA head for that specific mass only. The frequency of data acquisition is set in the Schedule setup. The time to acquire each partial pressure depends on the scan speed selected (the plotting speed depends on the user's computer). The Leak Test display mode cannot be split with other modes. The control view bar may be used to zoom, scroll and view all data, even if a scan in progress.

Annunciator (Mode Menu)

Annunciator mode provides an effective way to visually monitor gas warning levels from a distance. The graph is composed of large green panels each representing a gas and alarm level. The partial pressure value is clearly visible and so is the gas name. When an Alarm level is reached, the panel color changes to bright red, and the appropriate alarm message is shown. The gas masses, names, and parameters can be set using the Scan Parameters command from the Scan menu.

The Annunciator channels can be independently configured. Some channels can use the Channel Electron Multiplier (CEM) while others can have different scan speed with the CEM off.

The alarm control and level settings can be edited by either double clicking on the Alarm text of the desired Annunciator entry, or by clicking on the 'Alarm X' (where X is the channel number) button for the Annunciator channel in the Table Parameters dialog box.

The Schedule command (Scan menu) may be used to set the scan trigger frequency.

The Annunciator display mode cannot be split with other modes.

Important:

Table mode, P vs. T mode, and Annunciator mode share the same table scan parameters, alarm parameters, and graph trace colors.

In Annunciator mode each channel value (partial pressure) is acquired directly from the RGA head by individually querying the partial pressure for the appropriate mass. This is done for all the selected masses using the present scan schedule as a trigger.

Library (Mode Menu)

Library mode displays the selected library gas fragment patterns in a histogram graph. When split with a histogram or analog graph, the mass range of the library will automatically match that graph's range for easy comparison of gases. All library information is read from the "gaslib.dat ASCII file located in the same directory as "rga.exe". This file may be edited (with a text editor) to add, delete, or modify gases in the library. The exact library file format must be preserved for proper operation of this mode.

The Library Traces (bars) colors may be changed by either double clicking on the bars directly or by using the Traces command (Graph menu).

The library scan parameters (displayed mass range) may be changed using the Library Parameters command in the Scan menu. The cursor tool (Utility menu) can be used for the analog, histogram, PVST, leak and library modes.

Data Acquisition

The terms Data Acquisition and Scanning are used interchangeably in the SRS RGA documentation. A scan implies that the SRS RGA Head is performing ion current readings and sending the data over the RS232 cable to the PC running the RGA program at a fixed rate of 28.8 kBaud. This data is graphed using the currently active display mode chosen by the user. The speed of graphing depends on the hardware used and can vary with types of CPUs, video cards, Serial ports etc.

The main procedure for establishing a live scan is outlined below:

1. Turn on the SRS RGA Head.

2. Establish a connection between the RGA program and the Head (Connector List Setup in the Head menu, or Connector List button on the toolbar).
3. Select the desired display mode (Mode Menu).
4. Turn On the Filament (Head menu or Filament button).
5. Select the desired scan parameters (Scan menu).
6. Select the desired trigger rate (Scan menu).
7. Select the Start scan command (Scan menu or Start button).

Scan Data Logging

Scan Data logging (or scan logging) is used for saving raw scan data to disk without the overhead that comes with saving an RGA Head file.

Scan logging continuously saves scan data along with the time and date, with only the essential information about each scan. The user can easily browse through the scans after the scan logging is complete using the Next Item and Previous Item commands from the View menu.

Scan logging is implemented for all scanning modes. To save the data for the modes with time axis, simply select the Save command from the File menu. Scan logging is enabled by default to insure no data is every lost. Every scan mode has logging options. They can be changed buy selecting Scan Logging in the File menu. Spectrum Analysis can also be logged.

Graph Management

RGA is a fully interactive Windows program that allows the user to directly manipulate graphical objects on the screen by double-clicking on them with a point and click device such as a mouse or track ball.

Almost every graph object in every display mode may be edited by double clicking on it. The extent of the editing depends on the actual object. For example you may change the text color, font, and size of any graph title but you may only change the color of the bar graphs in Histogram mode. Some graph objects can be customized. Those objects can be relocated on the screen with a mouse by left clicking and dragging a cursor. Some of them also can be resized.

Every graph object that can be edited by double-clicking on it may also be edited by using an equivalent command from the Graph menu.

All graph parameters relating to graph objects are saved when the Save or Save As commands are used form the File menu.

Graph object parameters are local variables to the presently active display mode only. For

example, if the background mode in Analog mode is changed to yellow, the background mode of all the other modes remains unchanged. Also, any new file using the Analog mode still uses the default background color.

After an RGA file has been edited to have a desired look, it may be used as a template for new files by clearing its data using the Clear Graph Data command, saving it using the Save As command, and opening it again using the Open command.

Head Management

The SRS RGA Head has nonvolatile memory that stores most head variables such as sensitivity factors, Channel Electron Multiplier gain, high voltage, calibration factors, etc. When the RGA program connects to a head, all these variables are read from the head and stored temporarily in the program for use in the active file. When a head parameter is edited using the command in the Head menu, that parameter is stored back in the head immediately.

Saving RGA files does not save any of the head parameters to that file since each RGA Head has unique parameters due to minor variations in electronic and physical properties. Head parameters cannot be changed unless an SRS RGA Head is connected and turned on.

Protecting Your RGA

A Maintenance Schedule menu item lets you protect your RGA by automatically turning the filament or CEM off if the RGA is left to idle for a selected time.

Sensitivity Factors

The RGA Head uses two sensitivity factors stored in its non-volatile memory. The sensitivity factors, one for total pressure and one for partial pressure, are used as conversion factors between the ion currents received from the head and the pressure units selected by the user.

The sensitivity factors can be changed using the Sensitivity Tuning command in the Head menu. In order to set these factors, you need a reference ion gauge installed in the same vacuum system. The reading from the gauge is used to set the new sensitivity factor for the RGA Head.

Note: The pressure limits you may enter will change if you have the Pressure Reduction option enabled. If this option is enabled RGA lets you enter much higher pressure values.

Spectrum Analysis

Mass spectrum analysis takes you one step beyond visual analysis and Library lookup tables. RGA looks at the spectrum from 1 to 50 amu and uses a matrix inversion technique to analyze the composition of the residual gas and approximate its composition. Note that Analysis mode requires a minimum span of 1 to 50 amu. The span can be higher than 50 amu. Analysis data can also be logged by clicking the Enable Analyze Logging box in the Analyze Settings selection in the Utilities menu.

Background Data

This mode is helpful in providing the user with a clean baseline after the background data gets subtracted from newly acquired scans. This utility is available in Analog mode, Histogram mode, Table mode, and P vs. T mode. In Analog mode and Histogram mode the scan must be allowed to finish at the Stop mass before the data can be used as background. Use the Stop at End command from the Scan menu (if in continuous scan mode) to guarantee this condition.

In Analog and Histogram modes the full spectrum is subtracted from the newly acquired spectrum. In Table and P vs. T modes, only the last acquired partial pressure of each mass get used as a background data. When a Table or P vs. T mode is split with Analog or Histogram mode AND background is enabled, the data in the Table or P vs. T graph is extracted from the Analog or Histogram graph and NOT subtracted from its own previous data.

RGA Head and Scan Parameters

The following topics describe how a user might change any of the RGA Head or scan parameters. For specific command information please use the On-Line Help for the RGA Program.

Note: For detailed information and command description of the RGA program please refer to the RGA On-Line Help files provided on the program CD. The RGA help system includes a detailed description of all the features, procedures and commands available in the program.

Changing Scanning Parameters

Every display mode has scan parameters that are used to setup the display and to acquire data from the RGA head. Some modes such as the P vs. T, Table, and Annunciator modes share the same scan parameters. For example, if a scan parameter is changed in table mode, this change will be reflected in the P vs. T and annunciator mode when that mode is activated.

It is not necessary to be connected to an RGA Head to modify the scan parameters. The head will be updated when a connection is established.

To change the scan parameters do the following:

1. Select the desired display mode from the Mode menu.
2. Select the scan parameters command for the active display from the Scan menu. The scan parameter dialog also can be evoked by clicking on the tool button in the toolbar.

If the user accepts the new parameters, the display is recreated using the new parameters and, if an RGA Head is connected, its parameters get updated also.

Note: Changing scan parameters will result in loss of all displayed data on the screen. Use the File menu to save the data in one of the formats available before changing any scan parameters.

Changing Head Parameters

The head parameters menu items are available only when there is an SRS RGA Head connected and turned on. The head parameters are variables that depend on the actual RGA Head and reside in non-volatile memory in the RGA Head circuitry. These parameters are read from the Head when a connection is established and vary from one Head to another due to physical properties, electronic properties, and aging of the unit.

To change or view any of the Head parameters, do the following:

1. Connect to a head using the Connector List setup from the Head menu, or by clicking on the Connector List button on the toolbar.
2. Select an item from the Head menu.

If the operation is not canceled, the new parameters are stored in the Head and are used in subsequent operations.

Changing Scan Trigger Rates

The scan trigger rate (schedule) determines the frequency with which a scan is repeated. Not all display modes have the same schedule options. When changing trigger rates keep in mind the following:

- When a graph with a time axis is active, only timer triggered schedule is allowed.
- When a split mode is active, the graph with the more restrictive schedule is used for triggering scans.
- If a selected trigger period is smaller than the actual period of the scan, RGA will change the trigger period to the minimum value.

To change the scan schedule for a mode do the following:

1. Connect to an RGA Head.
2. Select the desired display mode.
3. Select the Schedule command from the Scan menu.
4. Select the trigger mode or rate you want.

IMPORTANT:

Since Windows can be running one of many applications at once, it is possible for the RGA program to miss a scan trigger while other applications are busy performing other tasks such as printing or file copying. These facts should be taken into account if optimum performance is desired when using Timer Triggered modes and display modes that use a time axis.

Scanning With The Filament Off

The software can run experiments with the filament off. This is useful only to researchers who perform experiments that generate their own source of ions.

The program will warn you if you start a scan without the filament turned on. This is done to prevent casual use and accidents. However advanced users who are going to use this mode frequently can disable the warning in the ionizer settings for a particular Rga Head, or just check the box "never ask me again" in the warning dialog.

Note: Using this mode presents some risk to the RGA hardware

With the filament off, the RGA has no method to detect total pressure. If the CEM is on, the RGA will not be able to detect a high pressure condition and will not automatically turn off the CEM. Without this protection, it is possible for the pressure to reach a level where a sustained electrical discharge will occur from the CEM to the surrounding wall.

Warning: The CEM will be destroyed by such a discharge.

The most likely situation during which this can occur is when shutting down a vacuum system. As the chamber is slowly vented, the pressure will reach the discharge region. Do not leave the RGA with the CEM on when a system is being shut down. Better yet, do not leave the RGA on at all when the vacuum chamber is being shut down.

This can also occur when power failures trip out the turbo pump of the vacuum system. As the pump coasts to a stop, the pressure rises to the discharge region. If you are going to use the RGA unattended with the CEM on, consider using an interlock to shut off power to the RGA if the turbo pump is not running. Many pump controllers have an outlet that is only powered when the pump is running. Plugging the RGA into this outlet would protect against this failure mode.

Note, with the filament off, the RGA will appear dead to a user who is expecting to run a normal experiment. The only indication that the filament is off, will be a lack of signal.

Because of these concerns, the "Filament On" mode is always initiated by default. Only a small number of users need this ability to operate without the filament on, and they must be fully aware that it is being enabled.

Display Modes

Note: For detailed information and command description of the RGA program please refer to the RGA On-Line Help files provided on the program CD. The RGA help system includes detailed description of all the features, procedures and commands available in the program.

Changing Display Modes

A display mode presents the user with a specific way to analyze the RGA data acquired. The RGA program has several display modes including a combination of those modes (split modes).

To change the present display mode to any other mode do the following:

1. Stop the scan if one is in progress.
2. Select the desired display from the Mode menu or click on one of the mode buttons in the Toolbar.

Running in Split Display Mode

Running in split display mode allows you to view scan data in two different formats or to scan two different sections of the mass spectrum with different scan parameter settings.

The following is a list of all the split display modes available:

- **Analog split with: Analog, Table, P vs. T, and Library**
- **Histogram split with: Histogram, Table, P vs. T, and Library**
- **Table split with : Analog, Histogram, P vs. T, and Library**
- **P vs. T split with : Analog, Histogram, Table, and Library**

You cannot split with Leak or Annunciator modes

To split a graph do the following:

1. Make sure you are running in any of the Analog, Histogram, Table, or P vs. T single graph modes.
2. Select any of the enabled graph modes from the Split Submenu of the Mode menu

Manual Scaling of Graphs

Manual scaling applies to graphs with an X-Axis, Y-Axis or Time-Axis. To manually scale a graph do the following:

1. Select the X-Axis, Y-Axis or Time-Axis by double-clicking on it or selecting X-Axis, Y-Axis or Time-Axis from the Graph menu.
2. Enter the new desired limits for the axis in the From and To parameters.
3. Select OK.

Using Scan Data as Background

This mode is helpful in providing the user with a clean baseline after the background data gets subtracted from newly acquired scans. This utility is available in Analog mode, Histogram mode, Table mode, and P vs. T mode.

To Enable the Background mode make sure the graph has valid data and the RGA head is connected. In Analog and Histogram mode the scan must be allowed to finish at the Stop mass before the data can be used as background. Use the Stop at End command (if in continuous scan mode) to guarantee this condition.

To Enable the Background:

1. If a scan is in progress, issue the Stop at End command from the Scan menu.
2. Select the Background Setup command from the Utilities menu.
3. Click on the Enable Background Mode check box to enable this mode.
4. Select the desired data subtraction mode.
5. Press OK.

The data gets cleared and the next scan will be the result of subtraction selected.

To Disable the Background:

1. Select the Background command from the Utilities menu.
2. Click on the Enable Background Mode check box to disable this utility.
3. Press OK.

When the background mode is disabled, the old background data reappears on the screen.

General Utilities

Note: For detailed information and command description of the RGA program please refer to the RGA On-Line Help files provided on the program CD. The RGA help system includes a detailed description of all the features, procedures and commands available in the program.

Using the Data Cursors

A real-time graphical cursor is available in all scanning modes. The cursor is on by default in all modes. When you select the cursor command (Utilities menu) in all modes except the Table or Annunciator mode a cursor appears on the graph. The vertical cursor can be moved to any point in the graph to identify the desired data value. In Analog or Histogram modes the cursor values are displayed in the text box on the right top portion of the graph. The cursor text box is an active graph object. Thus you can customize the position of the cursor box by selecting it and dragging it, or you can double-click on it to change the font or the size. The X and Y values of the cursor are updated every time the cursor is moved, or a new data value is acquired at the current cursor position.

In the Leak test mode the X value of the cursor text is displayed in time format.

In PvsT mode, the cursor values are displayed in the legend box. If the legend view is toggled off you cannot see the cursor values. This off-option can be useful if the legend box obscures some data points. You may move the cursor by either clicking on or near a data point of interest, or by clicking and dragging with the mouse with the left mouse button held down. You also can move the cursor incrementally by using the **LEFT** or **RIGHT** arrow keys.

In split mode, the cursor appears in both displays. You can move the cursor incrementally in the top display by using the **LEFT** or **RIGHT** arrow keys and in the bottom display by holding the **SHIFT** key down while using the **LEFT** or **RIGHT** arrow keys.

Scheduled Saving of Data

Logging Scans

Scan logging options are available for all scan modes. Scan logging is enabled by default. The logging settings are saved when a user exits the program.

To log scans to disk do the following:

1. Establish a connection between the RGA program and a Head.
2. Select a scan mode.
3. Customize the logging by selecting the “Scan Logging” command from the File menu or by clicking the “logging Folder” button in the toolbar. The logging directory must be selected for every scan mode or you can use default values assigned by the installation program. The log file name is created automatically. This saves valuable time for a user who always uses scan logging. If you don’t want to keep unnecessary data on your hard drive, you can periodically clean up the log dirs. You can select two different formats for the log file name. The first format file name is created by the concatenation of the title of the current document and the file timestamp. The second format file name is created by the concatenation of a user defined name and the file timestamp. The settings are stored, even if a user quits the program. More details can be found in the help menu.
4. Start a scan.

To disable scan logging, use the scan logging dialog box again.

Viewing Scans

To view a scan log, the active RGA display mode must be the same type of display mode that was used to log that scan.

To view the stored scans on disk do the following:

1. Select the Open Scan Logs from the File menu.
2. Select the desired scan log file (it must be the same type of scan as the currently active one).

3. Use the Next Item or Previous Item from the View menu to view the sequential logs (The time and date of the scan appears on each log).

Browsing Through the Gas Library

Library Browsing Description

There are several ways to browse through the gas library depending on the display mode and whether the Library Search utility is active. The Library display mode and search utility are linked together to provide an intuitive interface to locate and view any gas in the library file.

Library Display mode only:

1. Activate the Library mode by selecting the Library command from the Mode menu.
2. Use the Next Item and Previous Item in the View menu to plot the next and previous gases in the list (you may also use the left and right arrow keys).

Library Search utility only:

You may start this utility from any display mode

1. Start the search utility by selecting the Library Search command from the Utilities menu.
2. Press the Show All button to list all available gases.
3. Use the scroll bar, and/or the keyboard to search the list or use the Search Masses section to look for specific gases.

Library Display mode AND Search Utility:

The combination of these two modes provides a very quick way to look for gases.

1. Make sure both the Library mode and the Library Search utility are active (see procedure above).
2. If you want to plot a gas, double click on its name in the Search utility dialog box or click on it once (to highlight it) and press the plot button. The gas fragment pattern will then appear as a histogram in the Library display.

Analyzing the Mass Spectrum

Spectrum Analysis description

This utility provides the user with immediate analysis of residual gas based on a complete histogram or analog scan. Using a matrix inversion technique, the composition of the residual gas is analyzed and the best approximation to its composition is given in either pressure units or percentages. The user can enable up to 12 common gases for analysis.

Note: Analysis mode is only available in Analog mode or Histogram mode. The mass range must be at least from 1 to 50 amu.

Analysis Procedure

Make sure the RGA window is in either Analog mode or Histogram mode and connected to an RGA head. Set the scan range to be from 1 amu to at least 50 amu.

1. Select the Analyze command from the Utilities menu to bring up the Spectrum Analysis dialog box. You may place the dialog box anywhere on the screen.
2. Press the Setup button if you need to change the gas selection or the analysis units.
3. Select the Start command from the Scan menu (if not already scanning) to begin a scan.
4. When the scan is complete (the stop mass is reached) the analysis results will be displayed in the Spectrum Analysis dialog box. The analysis will be repeated every time the scan reaches the stop mass.

Note: You may enable or disable the analysis procedure even while the RGA Head is performing a scan.

The “Analysis Settings“ option (Utilities menu) allows customization of the Analyze mode. The list of 12 gases used in the Analyze mode can be changed interactively by the user directly from the program. A user also can enable/disable the logging of analysis data to the disk.

Pressure Reduction

If you purchased a pressure reduction system from SRS this feature allows you to display true pressure values using the pressure reduction factor that corresponds to your system. If pressure reduction is enabled, all pressure readings are multiplied by the pressure reduction factor before they are displayed.

IMPORTANT: Entering the wrong pressure reduction factor will result in erroneous measurements being displayed.

Head Calibration and Security

Note: For detailed information and command description of the RGA program please refer to the RGA On-Line Help files provided on the program CD. The RGA help system includes current and detailed description of all the features, procedures and commands available in the program.

Tuning the RGA Sensitivity

WARNING! The sensitivity tuning procedure should be performed by qualified personnel only. A mistuned RGA Head could give erroneous readings until it is retuned properly.

Please refer to the RGA Tuning Chapter for more information about tuning and calibration.

While performing the tuning procedure the total pressure in the vacuum chamber should be around 10E-6 Torr.

In order to set the sensitivity factors of the RGA Head you must have a reference pressure gauge installed on your vacuum system. There are two sensitivity factors, one for total pressure and one for partial pressure. Both factors are stored in non-volatile memory in the RGA Head.

To tune the sensitivity factors do the following:

Make sure you are connected to the head.

1. Select the Sensitivity Tuning command from the Head menu.
2. Select which sensitivity factor you would like to adjust from the Measurement Mode section (Partial or Total).
3. If you selected Partial Pressure then enter the mass whose pressure you will be measuring in the Mass Selection edit box.
4. Enter the pressure indicated by your pressure gauge in the Reference Pressure Reading.
5. Press the Measure button.
6. Press Accept to start using the new factor(s) or Undo to revert back to the old one(s).

Adjusting the CEM Gain

The CEM gain may be set to any desired value between 10 and 1,000,000. The RGA program will automatically search the required high voltage for such a gain if the Adjust button is pressed.

All data acquired while the CEM is ON gets divided by the gain automatically before it is displayed.

To change the CEM Gain do the following:

1. Connect to an RGA Head with a CEM option (Utilities menu).
2. Select the Channel Electron Multiplier command from the Head menu.
3. Select the Pressure Measurement Mode and the Partial Pressure Mass (if partial pressure is selected).
4. Enter the desired gain in the Gain edit box.
5. Press the Adjust button and wait for the procedure to finish.
6. Press OK.

Peak Tuning the RGA Head

WARNING!

The peak tuning procedure should be performed by qualified personnel only. A mistuned RGA Head could give erroneous readings.

Please refer to the RGA Tuning chapter of this manual for more information about tuning and calibration.

All the variables displayed are initially read from the SRS RGA Head when the dialog box is activated. When you are done with this procedure, the new parameters are stored in non-volatile memory in the RGA Head.

Activating this dialog box automatically puts the display mode in Dual Analog mode. The span is set to 10 amu with the two peak tuning gas masses set in the middle of each span. If you press Scan and you have sufficient gas amounts of each peak tuning gas, you should see the two peaks on the graphs. Use these peak for width and position adjustments.

Every time you make a change to any of the parameters, press the Scan button to see the effect of the change on the graph. Use the graph scaling command AutoScale to scale the data.

The peak tuning procedure must be performed in the order described below. You may repeat the entire procedure as needed until you are satisfied with the results.

To tune the RGA Head peaks do the following:

1. Select the two gases you are going to use for peak tuning. Use the Gas Selection command (Head Menu) to enter the gas names and masses.
2. Press Scan to see where the peaks are positioned. Rescale the graph as needed so you can see the gas peaks.
3. Enter a Position Shift value for the Low Mass Peak if the peak does not fall exactly at its required mass. Press Scan. Repeat this step as needed until the peak is at the correct mass.
4. Repeat step 3 for the High Mass Peak Position
5. Iterate between steps 3 and 4 as needed
6. Enter a Width Adjust value for the Low Mass Peak (if needed) and press scan (The full width of the mass peak at 10% of its maximum should be less than or equal to 1 amu).
7. Repeat step 6 for the High Mass Peak Width
8. Iterate between steps 7 and 8 as needed

When you are done you may:

- Press Done if you are satisfied with the results, or

- Press Undo ALL to revert to the initial settings, or
- Press Factory Settings to recall factory set values.

Securing the RGA Head

Use this feature in an environment where you would like to restrict access to the head parameters. When the RGA Head is locked, you cannot perform certain parameter editing procedures such as Peak Tuning, Sensitivity Tuning, and Ionizer parameter editing. The encrypted password is stored in the rga.ini file in the Windows directory.

To lock the head parameters do the following:

1. Select the Lock Head Parameters command from the Head menu or click on the Lock button in the main Toolbar.
2. Enter an alphanumeric password. The password is case sensitive.
3. Confirm the password exactly as entered above.
4. Press Lock.

To Unlock the head parameters do the following:

1. Select the Lock Head Parameters command from the Head menu or click on the Lock button in the main Toolbar.
2. Enter your password.
3. Press Unlock.

RGA On-line Help

The RGA Help system contains detailed information on the operation of the program that is not contained in this manual. Use the On-Line Help to get up to date detailed information on the RGA Windows program. The following sections describe the different ways to use the RGA Help system.

Help Search

You may search the RGA Help system for any topic or keyword. Once you have the RGA Help system window open, select the search command and enter any keyword to display that topic.

Help Index

Displays a comprehensive index to information contained in the RGA Help system.

To see the entries for a topic, click the first letter of the word you want to look up, or press TAB to select the letter and then press ENTER. Click on any entry highlighted in green and the topic for that entry is displayed automatically.

Commonly Asked Questions

A Q&A help file has been included with the RGA program. This file includes the most commonly asked questions about the SRS RGA system. Double click on the **RGA Q&A Help** Icon to view this file.

Sample Scans

The RGA Windows program includes several sample scan files that demonstrate some of the SRS RGA capabilities. The scan files are located in Scans subdirectory of the main RGA program directory. Double click on the **Sample Scans** Help Icon to view the description of the each scan file.

Chapter 3.

Measurement Techniques

This chapter discusses procedures to help the user make accurate measurements with the QMS. Several sections are devoted calibration and tuning procedures. The last sections discuss specific measurement techniques.

In This Chapter

Calibration	3-2
Effect of Total Pressure	3-3
Operating Off the Design Pressure	3-3
Total Pressure and Composition	3-4
Calibration of Partial Pressure	3-5
Initial Calibration	3-6
Basic Recalibration	3-7
Calibration for Multiple Operating Conditions	3-8
Calibration with Fixed Reservoir	3-8
Peak Tuning Procedure	3-8
General Procedure	3-10
Peak Position Tuning Algorithms	3-11
Peak Width Tuning Algorithms	3-12
Temperature Effects on the Mass Scale Calibration	3-14
Electron Multiplier Tuning Procedure	3-15
Techniques	3-16
Correcting for the Chamber Background	3-16
Correcting for Multiple Species	3-17
Operation with Condensable Gases	3-17

Calibration

The QMS has been calibrated at the factory to measure the partial pressure of nitrogen correctly. For many purposes this will be suitable. Overtime the calibration can change or operating conditions may change. There are many factors involved in calibrating the QMS and interpreting the mass spectra. To make accurate measurements, the following conditions need to be met:

- The total pressure needs to be known.
- The main sensitivity factor needs to be calibrated. Sensitivity factors change as a factor of time due to aging and periodic recalibration is necessary.
- For careful quantitative analysis, it is important that the sensitivity of the RGA be determined for every gas which may be a component of the system. Each gas component in the sample will fragment differently and will have slightly different sensitivities.
- Correct calibration of the mass scale is essential during qualitative analysis for the correct assignment of mass numbers to the different peaks. The mass scale will effect the peak height if it is more than 0.3 amu out of calibration.
- The mass resolution of the quadrupole mass filter, $\Delta m_{10\%}$, must be kept at or under 1 amu to avoid overlap between adjacent peaks. Changes in $\Delta m_{10\%}$ during the measurements (caused by aging, severe contamination and large temperature changes) will cause variations in the sensitivity of the instrument and the shapes of the fragmentation patterns of the molecules, affecting all quantitative measurements.
- The gain of the electron multiplier is mass dependent and needs to be determined prior to performing measurements with the device. The gain characteristics of the multiplier change with time and periodic recalibrations are very important.

The following sections of this chapter describe several procedures designed to assure that all the calibration conditions described above are satisfied prior to a set of partial pressure measurements. All tuning procedures can be executed from RGA Windows. Users writing their own programs can implement the procedures themselves, using the RGA Command Set and the instructions of this chapter.

All the tuning procedures require the ability to introduce pure gases (or a mixture of gases of known composition) into the system and a reference pressure gauge. All pressures are absolute; it is not possible to make measurements in gauge pressure.

Important: Tuning should only be attempted after the unit has been warmed up (with the filament on and under typical operating conditions) for at least one hour.

Effect of Total Pressure

Increasing the total pressure at the inlet of the capillary will increase the flow through the capillary. The higher flowrate in turn will increase the pressure at the RGA. This effect is not linear and in applications where the inlet pressure varies, the user needs to understand the flow at the inlet. The flowrate or throughput of the capillary is characterized by

$$Q = C(P_{in} - P_{out}) ,$$

where Q is the throughput (a mass flowrate), C is the conductivity of the capillary, and P_{in} & P_{out} are the pressures at the inlet and outlet of the capillary. The inlet pressure is much larger than the outlet pressure, which allows P_{out} to be approximated as zero. The conductivity is a function of the capillary dimensions, the viscosity of the gas, and the pressure drop across the capillary. This results in the throughput, Q , being proportional to the square of the inlet pressure. The diaphragm pump dictates the pressure at the outlet of the capillary according to

$$P_{out} = \frac{Q}{S_{DP}} ,$$

where S_{DP} is the speed of the pump. The speed of the diaphragm pump varies with throughput according to its characteristic curve, referred to as a speed curve. The speed curve is not linear. Because the pump has an ultimate vacuum it can achieve, the intercept of the curve is not even zero. The aperture and turbo pump respond linearly to P_{out} . Although all these factors can be modeled, the overall response of the QMS to total pressure is best characterized experimentally. A short experiment with the specific gas of interest, equipment and operating conditions will yield a curve describing how the pressure at the RGA varies with P_{in} .

Operating Off the Design Pressure

Each system is specified for one inlet pressure, the design point, which is atmospheric pressure for the standard capillary. The capillary accomplishes the first stage of the pressure reduction from the chosen design point to about 1 mbar. The aperture in the QMS is fixed, and designed to reduce the pressure from 1 mbar to about 5×10^{-6} mbar at the RGA. Each capillary is designed for the specific inlet pressure; mainly by choosing length and bore diameter. The inlet pressure to the capillary must always be such that the outlet pressure is less than 5 mbar. Operating the inlet at high pressures which would cause the outlet pressure of the capillary to exceed 5 mbar would cause two unacceptable effects: First, the turbo pump exhaust pressure would be excessive and slow the pump. The high pressure would increase the work load and cause excessive heating of the pump bearings. In the QMS, these fault conditions are prevented. The turbo pump contains a thermocouple which monitors the bearing temperature and shuts down the pump before it overheats. Also, the system microcontroller will shutoff the turbo pump and not restart it until the pressure is acceptable. The second effect is excessive pressure at the RGA, which can degrade the filament if it occurs for long periods. This fault condition is also prevented by two means. The RGA will shut off the filament when it senses the pressure is high and the system microcontroller will close the sample valve. These operating limits restrict the dynamic

range of the QMS with respect to increasing the inlet pressure above the design point. The instrument has little “head-room” and the capillary should be designed for the maximum expected pressure.

Below the design point, the QMS can tolerate large decreases in the inlet pressure. The ultimate vacuum of the diaphragm pump limits the lowest pressure at the outlet of the capillary, typically to 0.5 mbar. This pressure is the only operating limit; below it gas would flow out of the QMS. With respect to measurements, operating the outlet of the capillary near the ultimate vacuum of the diaphragm pump is inadvisable. At the ultimate vacuum, the flow through the pump is effectively zero. Operating the QMS with zero flow obliterates the fast response time of the instrument. While there are no physically harmful effects to operating below the design point, the ability to make measurements is lost at very low inlet pressures. Best performance of the system requires that the outlet of the capillary is between 1 to 3 mbar. The Technical Reference Manual discusses in greater detail the design of capillaries.

Total Pressure and Composition

The RGA measures **partial pressure** of the components in a gas stream. For ideal gases, the partial pressure is related to composition by

$$P_i = x_i P^T ,$$

where P_i is the partial pressure of the i -th component, x_i is the mole fraction of the i -th component and P^T is the total pressure. It is evident from this equation that a measurement of P_i cannot determine both x_i and P^T . To determine the composition, x_i , a value for P^T must be known. In many applications total pressure is constant and therefore partial pressure is proportional to mole fraction. When total pressure is not constant, a method of determining its value must be employed to allow composition to be determined.

In theory, the sum of the partial pressures determines the total pressure, *i.e.*

$$P^T = \sum_i P_i .$$

In practice, this summation requires care. For example, when using the P vs. t mode to acquire data, make sure to record all the major components of the gas being analyzed. Beware of overlapping peaks; these complicate the analysis. For example, consider a 50/50 mixture of nitrogen and carbon dioxide. The parent peaks for these gasses are at 44 and 28. Referring to the library in the software shows that nitrogen produces a peak at masses 28 and 14 that are 93% and 6% of the partial pressure and that carbon dioxide produces a peaks at masses 44 & 28 that are 78% & 9% of the partial pressure. For a 1000 mbar total pressure, the spectrum would show peaks at 28 & 44 with heights of 510 and 390 mbar. An error can be demonstrated by using these peak heights and reversing the calculation, while ignoring the interference. The carbon dioxide partial pressure would be correctly calculated as 500 mbar ($=390/0.78$), but the nitrogen would be erroneously calculated as 548 mbar ($=510/0.93$) mixture. The mixture appears to be present at a total pressure of 1048 mbar and a composition of 52/48. The correct calculation would first subtract the component of the peak at mass 28 which was caused by carbon dioxide, before calculating the nitrogen partial pressure. More discussion of the quantitative analysis of complex mixtures can be found in the texts listed in the Reference section.

Calibration of Partial Pressure

All quantitative calculations performed with the RGA rely on the assumption that there is a linear relation between the partial pressure and the corresponding RGA signals of the gases. Each gas ionizes differently, and its ions make it through the mass filter with different efficiencies. As a result the proportionality constant relating the ion current of a gas to its partial pressure is dependent on the specific gas.

The **partial pressure sensitivity** of the RGA to a gas g , S_g , is defined as the ratio of the change ($H-H_0$) in principal mass peak height to the corresponding change ($P-P_0$) in total pressure due to a change in partial pressure of the particular gas species. H_0 and P_0 are background values.

$$S_g = (H-H_0) / (P-P_0)$$

The units of S_g are of ion current per unit pressure (amp/Torr, for example).

The sensitivity of the RGA changes with time due to aging of the probe, and is a strong function of the operating conditions of the instrument. Careful quantitative analysis requires that the sensitivity factor, S_g , be determined for every gas which may be a component gas in the system being analyzed. The sensitivity factors must be obtained under the same operating conditions that will be used during general partial pressure analysis since they depend on many instrumental parameters, including: ionization energy, emission current, mass filter setting, type of detector, etc.

Important: In order to separate the gain of the electron multiplier from the intrinsic sensitivity of the RGA head, the sensitivity factors of the RGA are defined for Faraday Cup detection. A separate Electron Multiplier Gain Factor, is used to correct the ion signals when the electron multiplier is used. See the Electron Multiplier Tuning section for details.

Two calibration factors are used in the QMS system: the RGA sensitivity and the pressure reduction factor. The RGA sensitivity is the factor which converts the ion current that is measured by the electrometer to partial pressure at the ionizer. The pressure reduction factor accounts for the large pressure reduction performed by the two stage inlet (capillary and aperture). Determination of these factors requires comparing the system with a known-accurate pressure gauge and calculating the factor that makes the QMS agree with the standard. Calibration is not necessary on a frequent interval, but is required whenever operating conditions change.

The RGA intrinsically measures an ion current, which is proportional to the partial pressure at its ionizer. While the software can be set to report ion currents, most users will need to measure partial pressure at the inlet of the capillary. To convert between the two, the partial pressure reported by the software is calculated by the formula:

$$P_i = \text{ion current (A)} \times \frac{\text{pressure reduction factor}}{\text{sensitivity factor (A Torr}^{-1}\text{)}} = \text{ion current (A)} \times \text{overall factor (Torr A}^{-1}\text{)} .$$

The pressure reduction factor is a function of the capillary dimensions, the performance curve of the pumps, and the dimensions of the aperture. The sensitivity factor is a function of the precise dimensions of quadrupole and ion optics, the state of the detector, the ionizer filament, and the four parameters which

control the filter (electron energy, focus voltage, ionizer current, and ion energy). In the equation above, the two factors are unknown. During calibration only the standard partial pressure and measured ion current are known. Therefore, both factors cannot be determined; only the overall factor can be determined. Both factors can be determined if a second reference pressure gauge is introduced into the RGA chamber. While this approach would yield another reference pressure and allow both factors to be accurately determined, it has no practical benefit.

Because only the ratio of the two factors is relevant, strictly speaking, one of the factors could be chosen to be any number. An obvious choice is to make one of the factors equal to one and use only the other. Because the sensitivity factor is stored in the RGA, this choice causes practical problems. The RGA firmware limits the sensitivity factor to reasonable values. The sensitivity factor must be on the order of 10^{-4} to 10^{-5} A Torr⁻¹, which are typical values. The pressure reduction factor is stored by the software in each .RGA file. With the two values stored in different locations, there are benefits for using each to account for various components of the overall calibration factor.

Both factors cannot be determined; therefore, each time the instrument is calibrated, one of the factors will be assumed to be correct, and the other will be adjusted to make the measured and reference values agree. The strategies for using each value are discussed in the following sections, starting with the basic technique that was performed at the factory.

Initial Calibration

Initially, a default value is stored in the RGA for its sensitivity factor. This factor is displayed by selecting the “Head|Get Head Info...” menu item in the software. This value was determined at the factory using a reference ion pressure gauge. Users can resort to this default value when they wish to completely recalibrate the instrument. The pressure reduction factor is calibrated using the partial pressure of nitrogen present in air using the following steps:

1. Determine the barometric pressure, which is typically reported in “in Hg”. Example: on a typical clear day the pressure is 29.95 in Hg or 761 Torr (1 in Hg = 25.4 Torr).
2. Nitrogen is naturally present at 78.1% of total pressure. Multiply by this factor to yield the partial pressure. Example: on that day nitrogen is present at 594 Torr.
3. Gases break into molecular fragments in the ionizer. For common gases, fragmentation factors exist that indicate what fraction of the molecules remain intact. For nitrogen 92.6% of the molecules will remain intact and will be measured at mass 28. Multiply the partial pressure by this fraction to determine the reference value. Example: the reference value would be 550 Torr.
4. With the pressure reduction factor disabled (or set to 1), measure the peak at mass 28. Example: the system indicates 1.3×10^{-6} Torr at mass 28.
5. The pressure reduction factor is the reference value divided by the measured value. Example: the factor is calculated to be 4.2×10^8 for this instrument.
6. Enter this number in the pressure reduction factor dialog box and check the enable box.

This completes the calibration. All modes of the software will now report partial pressure at the inlet to the capillary. Be sure to record these values as they can be used to diagnose system performance. The pressure reduction factor is saved in the .RGA file; make sure to select File|Save to record the new pressure reduction factor.

Basic Recalibration

Some situations will require recalibration of the instrument. For example:

- aging of the diaphragm pump and ionizer filament
- small changes in the total pressure at the capillary inlet
- small dimensional changes to capillary and aperture

For users of one capillary and one input stream, an easy method of making small changes to the calibration values is available with the Sensitivity Tuning feature of the software. Under this method, we assume that the pressure reduction factor is correct and change the RGA sensitivity factor.

Nitrogen is the most common recalibration gas, and in this example, we assume that the partial pressure of nitrogen in air is used as a reference. While air is convenient, the recalibration can be performed with any test gas as a reference. Follow these steps to recalibrate the QMS:

1. Make sure that the pressure reduction factor is enabled and correct in the dialog box that appears under the “Utilities|Pressure Reduction...” menu item.
2. Setup the QMS to sample the reference gas.
3. Choose the “Head|Sensitivity Tuning...” menu item to make the Sensitivity Tuning dialog box appear. Make sure the Measurement Mode is set to Partial Pressure and that the Mass Selection is set to the parent peak of the reference gas.
4. Enter a value in the Reference Pressure Reading edit box that is the expected value for the pressure at the capillary inlet. This value should be adjusted for the fragmentation factor as done above (92.6% for peak 28 from nitrogen). As in the example in the previous section, the reference reading is 550 Torr for nitrogen in air at a barometric pressure of 29.95 in Hg.
5. Observe the value in the Sensitivity Factor text box and then press the Measure button. A new value will be displayed in the text box, which should be close to the old value.
6. Press the Accept button to store the newly calculated value into the RGA or the Undo button to restore the previous button.

The instrument is now recalibrated. Note that the new sensitivity factor is only correct when used with .RGA files that contain the matching pressure reduction factor. This procedure can be repeated frequently to make minor adjustments to the overall sensitivity factor. Because the range of the RGA sensitivity factor is limited by firmware, this procedure cannot be used to account for large changes in the overall sensitivity factor.

Calibration for Multiple Operating Conditions

The QMS capable of being used over a variety of operating conditions, which in turn require different overall sensitivity factors. Examples are:

- one QMS system used with multiple capillaries
- measurements of gas streams at different total pressure, temperature, or composition
- measurements at multiple ionizer conditions

The RGA sensitivity factor is not meant to be directly adjusted by the user. The software only allows this value to be changed via the Sensitivity Tuning dialog box using a reference gauge reading. Users cannot type a new value into the Sensitivity Factor text box. Instead, the Pressure Reduction Factor feature is provided to account for widely varying operating conditions.

The Pressure Reduction Factor is stored in the .RGA files. When using the QMS with various operating conditions, one .RGA file can be made for each set of conditions. Each of these files will contain a different pressure reduction factor. The procedure to determine the pressure reduction factor is the same as used in the Initial Calibration section above. Briefly: disable the pressure reduction factor, compare the measured value with a reference, and calculate a new pressure reduction factor. When determining the pressure reduction factor for each set of conditions, make sure that the RGA sensitivity factor has not been changed.

To use the QMS at one of the multiple conditions, simply open the appropriate .RGA file and connect the window to the ECU (if the ECU is already connected to another window, disconnect from that window first). The software will now be ready to make measurements.

It is worth restating that the pressure reduction factor is only accurate when used with the matching RGA sensitivity factor. The value in the RGA electronics can be changed by other users, so the RGA sensitivity factor should be recorded or locked using the security feature of the software.

Calibration with Fixed Reservoir

Air is a convenient calibrant gas for the QMS, but only provides nitrogen as a useful reference. The other major components, *e.g.* oxygen, water, and carbon dioxide, are not present at reliable concentrations. For more precise calibrations a reservoir and pressure gauge can be used as a calibrant. When using this method, be aware that the QMS continuously draws 1-5 milliliter per minute of gas, depending on the capillary. The reservoir should be large or the total pressure will change quickly.

Peak Tuning Procedure

When analyzing a sample, you expect the peaks of the different gases to be displayed at their correct mass-to-charge ratio values and the peak widths to be less or equal than 1 amu at 10% of peak height. The correct location of the peaks is essential for accurate qualitative analysis, and unity resolution ($\Delta m_{10\%}=1$ amu) minimizes the overlap between adjacent peaks. Both the calibration of the mass scale and the widths of the peaks can vary with time due to aging of the head. Changes in resolution are particularly serious since they affect the sensitivity of the RGA and introduce errors in the partial pressure measurements.

The Peak Tuning procedures described in this section allow the user to calibrate the mass scale and the resolution, $\Delta m_{10\%}$, of the mass spectrometer. The RGA has a very solid design and this type of tuning procedures should rarely be needed.

WARNINGS

The peak tuning procedures should be performed by qualified personnel only. A mistuned RGA Head will give Erroneous Readings until it is retuned properly.

Peak Tuning should only be attempted after the unit has been warmed up (with the filament on and under typical operating conditions) for at least a one hour.

Peak Tuning requires a mixture of gases whose mass spectra is well known. In general, a two gas mixture, one with low mass peaks and one with high mass peaks, is sufficient. The sample is introduced into the vacuum, and the quadrupole mass filter parameters, referred to as Peak Tuning parameters, are adjusted based on the sample analog spectra. The mass scale is adjusted so that all peaks are displayed at their correct mass-to-charge values, and the peak widths, $\Delta m_{10\%}$, are adjusted to unity (or smaller) values. The two tuning procedures are referred to as Peak Position and Peak Width Tuning, respectively.

Note: A mixture of He, Ar, Kr and Xe inert gases is used at SRS to Peak Tune the RGA's. The resolution is adjusted to 1 amu and peak tuning parameters are saved into the RGA ECU before shipping. The inert gases cover a broad spectral range, and being inert they do not interact with the RGA probe and do not contribute to its aging.

Peak tuning can be easily performed with RGA Windows using the Peak Tuning command of the Head Menu. The program provides password protection for locking out the Peak Tuning Parameters so that casual users cannot alter the mass scale calibration or the spectrometer's resolution.

An extra copy of the tuning parameters determined at the factory for the mass filter is saved in the RGA Head before shipping, and those values can be retrieved at any time in case they are necessary. Consult the RGA Windows chapter of this manual or the RGA On-line Help Files included with the program for details.

Note to Supervisors: A calibration disable jumper (JP100) can be configured to block any attempt to change the value of the mass filter settings in the RGA Head. The jumper is located on the top electronics board of the ECU box, next to the microprocessor chip (i.e. biggest component on the board), and its two settings are clearly indicated as CAL DIS and CAL EN. Supervisors may use this feature to prevent accidental changes in the calibration parameters by inexperienced operators. Peak tuning is completely disabled when the jumper is configured to the CAL DIS setting.

Tip: Virtually every vacuum system will have detectable amounts of hydrogen (2 amu), water (18 amu), carbon monoxide (28 amu) and carbon dioxide (44 amu). Become familiar with these species and their fragmentation patterns, and use their peaks to quickly verify the correct performance of the instrument (i.e. mass scale calibration and mass resolution) while operating the RGA.

General Procedure

Peak tuning is a simple procedure that requires the introduction of two known gases into the vacuum system. A low mass gas (1-20 amu recommended) is used to adjust the low end of the mass axis, a high mass gas, with a mass-to-charge ratio close to the upper limit of the instrument's mass range, is used to adjust the high end of the mass scale.

Several analog scans are performed on the sample and the peak positions and widths are checked and adjusted as necessary. Changes in resolution affect the sensitivity of the RGA, and a Sensitivity tuning procedure should always be performed at the end of the peak tuning process.

The entire procedure can be carried out with the help of the Peak Tuning command (Head Menu) of RGA Windows. The program guides you through the calibration procedure and automatically updates the Peak Tuning Parameters in the RGA Head based on the results of the calibration.

The overall adjustment procedure is very simple and must follow the order described below:

1. Low mass peak position adjustment
2. High mass peak position adjustment
3. Repeat 1 & 2 in that order one or two more times until no more changes in peak positions are observed.
4. Low mass resolution adjustment
5. High mass resolution adjustment
6. Repeat 4 & 5 in that order until no more changes in peak width are observed.
7. Repeat 1 & 2 in that order one or two more times in the case steps 4 & 5 caused changes in peak positions.

Important: Collect a fresh analog scan for each step. The peak positions are adjusted such that all peaks throughout the scanning range of the RGA fall within +/- 0.25 amu of their known mass-to-charge ratio (This is needed to make sure the Peak-locking algorithm used for single mass measurements always finds the mass peak within its search window). The peak width, $\Delta m_{10\%}$, must be a constant, and less than 1 amu throughout the whole scan range.

Example: The following figure shows the result of peak tuning the RGA based on the $^{18}\text{H}_2\text{O}^+$ (low mass= 18 amu) and $^{86}\text{Kr}^+$ (high mass=86 amu) calibration peaks. All peaks are at their correct mass settings and show absolute resolution values of about 0.9 amu. Also note a 20 amu peak in the low mass spectrum corresponding to $^{40}\text{Ar}^{++}$ at 20 (i.e. 40/2) amu.

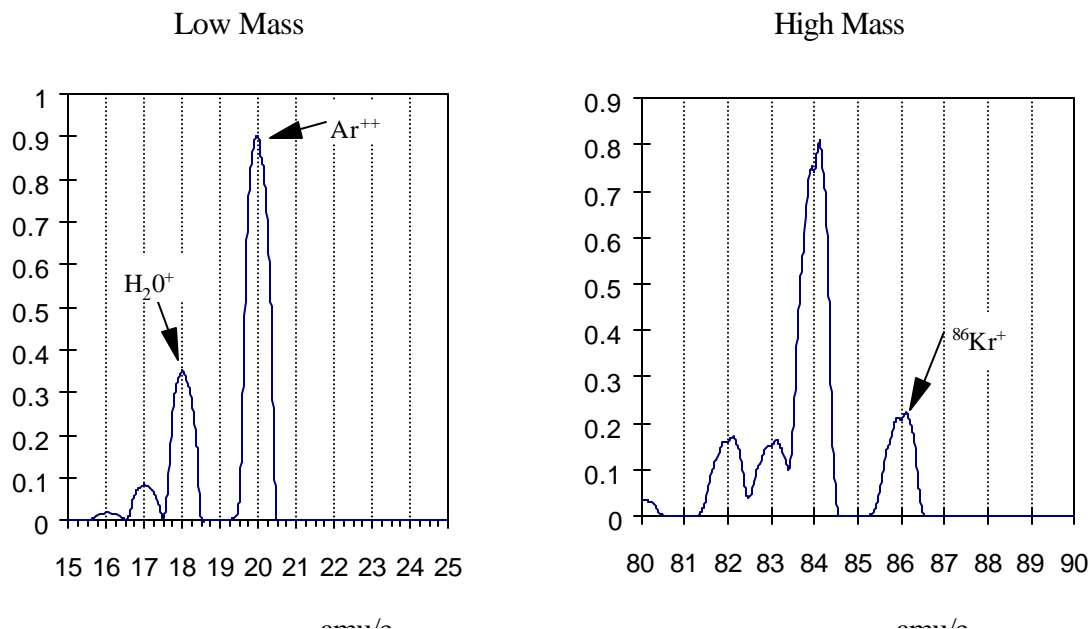

Users writing their own computer code can write Peak Tuning Commands for their own programs using the Tuning Commands of the RGA Command Set and the instructions of the following two sections.

Peak Position Tuning Algorithms

The magnitude of the RF determines the mass-to-charge ratio of the ions that can pass through a quadrupole mass filter without striking the rods (i.e. with stable oscillations). A linear relationship between mass and RF amplitude is one of the most attractive features of these type of filters. The regulated output of the RF source that powers the RGA's quadrupole rods is controlled by, and linearly related to, the voltage output of an RF Driver circuit. The RF Driver uses an 18 bit digital-to-analog converter and some additional electronics to program its output voltages.

The purpose of the Peak Position Tuning Procedure is to determine the voltages that the RF Driver must output at 0 and 128 amu so that all the peaks in an analog spectrum appear in the right place in the mass axis.

The calibrated voltage settings, in mV, are saved in the non-volatile memory of the RGA Head (RI and RS commands respectively) and used by the firmware to generate the internal scan parameters used to step the RF during scans and single mass measurements. Please consult the Tuning Commands List in the RGA Programming chapter of this manual for details on the RS and RI commands.

As described above, the peak position tuning procedure requires the introduction of two known gases into the vacuum system. A low mass gas (1-20 amu recommended) is used to adjust the low mass end of the mass axis, a high mass gas, with a mass-to-charge ratio close to the upper limit of the scanning range of the RGA, is used to adjust the high mass end of the mass scale. Several analog scans are performed, and the values of RI (RF Driver output @ 0 amu) and RS (RF Driver output @ 128 amu) are adjusted until all mass peaks appear at the correct position in the mass

scale. An increase in RI causes the low end of the analog spectrum to displace towards lower masses (A small effect is seen at the high masses). An increase in RS results in the spacing between peaks in a scan to decrease (with the largest effect seen at the high mass end).

The formulae used to correct the calibration parameters during peak position adjustment are presented next:

Low Mass Peak Position Adjustment: To displace a low mass peak by a distance Δm amu in the mass axis the value of RI must be modified from its original value RI_0 according to:

$$RI = RI_0 - \Delta m \cdot (RS / 128)$$

Notes:

- The new RI value must fall within the acceptable parameter range of the RI command.
- This change mostly affects the position of the peaks at the low end of the spectrum.
- A decrease in RI shifts the low mass peaks to the right (peaks show up at higher masses) , an increase in RI shifts the same peaks to the left (peaks show up at lower masses).

High Mass Peak Position Adjustment: To displace a high mass peak, m_0 , by a distance Δm amu in the mass axis modify the value of RS from its original value RS_0 to:

$$RS = RS_0 \cdot [m_0 / (m_0 + \Delta m)]$$

Notes:

- The new RS value must fall within the acceptable parameter range of the RS command.
- Modifying RS affects the spacing between peaks in the spectrum. An increase in RS results in the peaks getting closer together, and a decrease in RS results in the peaks getting further apart from each other.
- The effect is more significant at the higher masses and should have very little effect on the position of the low mass peaks (that is why you do this adjustment second).
- The lower the mass-to-charge ratio of the low mass gas the less this adjustment will effect the position of its peak.
- See that a decrease in RS results in the high mass peaks moving to higher masses (right shift), and vice versa.

Iterations: In most cases it will be necessary to repeat the two position adjustments one or two more times until both low and high mass peaks show up at their known positions.

Peak Width Tuning Algorithms

Constant absolute resolution ($\Delta m_{10\%}$) in a quadrupole mass filter requires DC voltages linearly related to the mass, with a slight negative offset at low masses (i.e. negative intercept).

The RGA Head adjusts the DC levels of the quadrupole filter during measurements so that constant mass resolution is automatically available throughout the entire mass range of the spectrometer. The bulk of the DC voltage is supplied by a DC power supply whose output is linearly related to the RF amplitude. The rest of the DC voltage (DC_Tweak) is provided by the output of an 8 bit digital-to-analog converter (DAC). The firmware uses two Peak Tuning Parameters : DI (Intercept) and DS

(Slope), stored in the non-volatile memory of the RGA, to calculate the 8 bit settings of the DAC according to the linear equation:

$$\text{DAC8}(m) = \text{DS} \cdot m + \text{DI} \quad (\text{DC_Tweek}(m) = (\text{DAC8}(m) - 128) \cdot 19.6 \text{ mV})$$

where m is the mass in amu, and $\text{DAC8}(m)$ is the 8 bit setting at that mass.

The purpose of the Peak Width Tuning Procedure is to determine the values of DI and DS so that all the peaks in an analog spectrum have the desired peak width (typically $\Delta m_{10\%} = 1$ amu). The calibrated parameters are saved in the non-volatile memory of the RGA Head (DI and DS commands, respectively) and used by the firmware to generate the internal scan parameters used to adjust DC_Tweek during scans and single mass measurements. Please consult the Tuning Commands List in the RGA Programming chapter of this manual for details on the DS and DI commands.

Note: The sensitivity of the peak widths to the DC_TWEEK voltage can accurately be approximated to: -1 amu per 550mV (28 bits). In other words, a 550 mV increase in DC_Tweek voltage causes a 1 amu decrease in the width of any peak. The DC_Tweek voltages span from -2.5 to +2.5 V with increments of 19.6 mV per bit (255 total bits). This corresponds to a peak width adjustment range of +/- 4.5 amu and minimum increments of 0.036 amu per bit.

As described above, the peak width tuning procedure requires the introduction of two known gases into the vacuum system. A low mass gas (1-20 amu recommended) is used to adjust peak widths at the low end of the mass scale, a high mass gas, with a mass-to-charge ratio close to the upper limit of the scanning range of the RGA, is used to adjust the widths at the high end of the mass scale. Several analog scans are performed on the sample and the values of DI (nominally 128) and DS (nominally 0) are adjusted until all peaks appear at their correct setting. The formulae used to correct the calibration parameters during peak position adjustment are described next:

Low Mass Peak Width Adjustment: To increase the low mass peak width by an amount Δm AMU's modify the value of DI from its original value, DI_0 , to:

$$\text{DI} = \text{DI}_0 - \Delta m * 28$$

Notes:

- The new DI value must fall within the acceptable parameter range of the DI command.
- A change in DI affects the width of all the peaks in the spectrum.
- A decrease in DI results in broader peaks at a rate of 0.036 amu per bit removed.

High Mass Peak Width Adjustment: To modify the high mass peak width by an amount Δm AMU's, modify the value of DS from its original value DS_0 to:

$$\text{DS} = \text{DS}_0 - 28 * (\Delta m) / m_0$$

Notes:

- The new DS value must fall within the acceptable parameter range of the DS command.
- Modifying DS affects the width of peaks at the higher end of the spectrum. An increase in DS results in the peaks getting sharper, and a decrease in DS results in the peaks getting broader

- The effect is more significant at the higher masses and that is why we do this adjustment second after the width has already been modified by the change in DI.
- If the mass-to-charge ratio of the low mass gas is real low this adjustment will have a small effect on the width of its peak.

Iterations: In most cases it will be necessary to repeat the two width adjustments one or two more times until both low and high mass peaks show the desired widths.

Note: Changes in the peak positions will also be observed, at a rate of -0.40 amu per amu of increase in peak width, and a Peak Position Tuning procedure will be needed to put the peak positions back where they belong.

Important: The Peak Width Tuning Procedure can be used to adjust the resolution of the RGA to the ultimate theoretical limit of the mass filter. See the Quadrupole Mass Filter section of the RGA Probe chapter of this manual for details on that limit.

Temperature Effects on the Mass Scale Calibration

As the temperature of the RGA Head changes two different effects affect the calibration of the mass scale:

- **For small temperature changes:** Drift in the voltage output of the RF Driver that controls the RF power supply can cause the mass peaks to shift their position in the mass spectrum. In order to correct against this effect, the RF driver output is checked at the beginning of each analog and histogram scan at 0 and 128 amu. The internal calibration parameters, used by the firmware to step the RF during scans, are updated so that the control levels specified by the RI (0 amu) and RS (128 amu) parameter values are correctly set at the present temperature.
- **For large temperature changes:** The sensitivity of the RF power supply to its controlling voltages might be affected or, more fundamentally, the relationship between mass and RF levels in the filter might change. In this case a Peak Tuning procedure will be necessary to reestablish the mass axis scale.

Electron Multiplier Tuning Procedure

Accurate quantitative measurements with the electron multiplier detector require the determination of the CDEM gain for all the ion peaks being measured. Frequent recalibrations are recommended to correct against aging of the device.

The gain of the electron multiplier (CDEM) in the RGA is defined relative to the Faraday Cup output (which is assumed to be mass independent). It can be programmed anywhere from 1 to 10^7 adjusting the high voltage applied across the device, is highly mass dependent, and changes with time due to aging.

The electron multiplier gain is easily calibrated in the RGA since it is possible to measure the same ion current with and without the CDEM. The common method of calibrating the electron multiplier gain for a given mass peak is to measure the peak intensity with the Faraday cup, and then repeat the same measurement with the electron multiplier without changing anything else. The gain of the multiplier is the ratio of the multiplier output current to the Faraday cup output current. (Note that there is no need to change the sign of the electron multiplier signal prior to the division since the firmware automatically reverses its sign before transmitting the value.)

The RGA Head can store a single set of [High Voltage, Gain] values for the electron multiplier in its non-volatile memory. RGA Windows uses the voltage value to bias the CDEM and the gain value to divide the ion currents when the CDEM is turned on. See the HV, MV and MG commands in the RGA Command set for details on the command-level implementation of this procedure.

RGA Windows can automatically program the gain of the electron multiplier for any mass using the automatic Electron Multiplier Gain Adjustment function of the Electron Multiplier command (Head Menu). Select a gain value between 10 and 1,000,000, choose a mass value for partial pressure measurements, and the RGA program automatically calculates the required high voltage setting when the Adjust button of the Electron Multiplier Window is pressed. The HV and gain settings are saved into the RGA Head and used every time the CDEM is turned on. All data acquired while the CDEM is on gets divided by the gain automatically before it is displayed.

Techniques

Correcting for the Chamber Background

Even with the sample flow and capillary flow valves closed, there will be a noticeable background in the mass spectrum. This background in the analyzer chamber is caused by outgassing from the chamber surfaces, backstreaming through the turbomolecular pump, and gas production from the ionizer of the RGA. These three processes account for the ever present background of hydrogen, water, nitrogen, oxygen, and carbon dioxide seen in high vacuum. The outgassing of water can be minimized by extensive pumping with both valves closed; typically the system can achieve water partial pressures around 1×10^{-8} mbar. The other two processes (backstreaming and ionizer) are fundamental and cannot be reduced. The ultimate vacuum of the turbo pump causes nitrogen to be present at no lower than 2×10^{-9} mbar and oxygen at 1/4 of that level. Carbon dioxide from the ionizer will be present at levels from 10^{-9} to 10^{-7} mbar. The software contains a background subtraction feature that allows the chamber background to be removed from the mass spectrum.

The background spectrum is correctly measured with the sample valve closed and the capillary flow valve open. When the capillary flow valve is open, the pressure at the exhaust of the turbo pump is the same as it will be when the sample is measured. Thereby, the backstreaming component of the mass spectrum will be the same as in the sample measurement. The software can only subtract two spectra when they cover the same mass range. Set the software to acquire the spectrum (either histogram or analog) at the speed, range, and schedule you require. To obtain a background subtracted spectrum, follow these steps:

1. Measure one complete analog or histogram mode spectrum with the sample valve closed. If the software was set to scan on a continuous schedule, you can select “Stop at End” from the “Scan” menu to stop when the current scan in progress is complete. The data displayed must be a complete scan, and be measured with the same parameters as the scans to follow.
2. Under the Utilities menu, select “Background” and select “Scan Data - Background” from the dialog box. Check the box next to “Enable” and select “OK” to close the dialog box. This makes the current spectrum the background and all spectra displayed subsequently will have this spectrum subtracted from it.
3. Open the sample flow valve and start the scan with the “GO” button. The newly acquired spectra are the background corrected result.

The ability to subtract background is limited by signal proportional noise, which is typically present at between 1-10% of the signal magnitude. Because this noise originates in the ionizer of the RGA, subtraction cannot remove much more than 90% of the background. This limits the ability to see small changes of less than 1% at the same mass as peaks present in the background.

Correcting for Multiple Species

As discussed above, the QMS is calibrated at one mass number. Because every gas behaves differently, analog scans can only show peak heights that are correct at the one mass number. It is not possible to correct the analog and histograms at every mass number. The RGA would have to know what species was causing the ion current at each mass. As an example: is ion current at a m/z of 16 caused by a fragment of H_2O (O^{+1}), a fragment of O_2 (O_2^{+2} , or O^{+1}), or CH_4^{+1} . Many of the peaks in a mass spectrum have multiple sources. To demonstrate this to yourself, use the library search on almost any single mass number. Except for a few values, the search will retrieve multiple species for almost all the low mass peaks. Without knowledge of what species is causing what peak, the correction cannot be made automatically. Practically, this is not a problem; the histogram and analog modes are intended to show qualitative composition.

The table modes (table, P vs. t, and annunciator) contain a calibration factor for each species. These factors are provided to resolve the problem with the mass spectrum just discussed. The user can use these factors to tell the software how to correct for each peak. To determine the correct calibration factor to use, you must know (or assume) what species is causing each peak and choose masses that are not complicated by other species. Choosing the correct peaks is complicated and requires understanding of the mass spectrum. For instance in a 50/50 mixture of nitrogen and carbon dioxide, you cannot use mass 28 to measure the nitrogen. With this mixture, about 10% of the peak at 28 would be caused by a CO^+ fragment. A better choice would be to use the peak at 14 to measure nitrogen. Once you have chosen a mass that is representative of each species of interest, you then refer to published fragmentation factors (see references) to determine how to correct back to the parent peak. Even if the instrument was calibrated for nitrogen, it was likely calibrated on the peak at 28. The peak at 14 will not be correct; it will be about 7% of the correct value. Entering 14.2 (1/0.07) as a calibration value in the table parameters allows the software to correct the partial pressure reading. Similar calibration factors are entered for each species being measured. A calibration gas of known composition makes process of determining factors easy. First make a measurement of the standard with all the factors set to 1. From this measurement, a correction for each species can be calculated and entered into the tables. The references listed at the end of this manual contain discussions about how to interpret mass spectra from RGA's.

Operation with Condensable Gases

The QMS is designed to sample gases that are nominally at room temperature. Under these conditions, any species that is a gas in at inlet conditions can be expected to travel through the instrument without condensing. Without a heat input, a gas will cool as it expands through a capillary and pressure reduction aperture (according to its Joule-Thompson coefficient). In the QMS system, the absolute pressure difference across the aperture is small and the flow rate is small; under these circumstances the interior metal surfaces can provide sufficient heat to the expanding gas to keep it from condensing. If problems due to condensation are suspected, the capillary can be wrapped with heating tape to test for condensation. The goal of heating the capillary is to increase the heat transfer rate to the sample gas.

When the gas being measured is significantly hotter than the QMS system, condensation is likely and presents a problem. If the species at the inlet are gases only at temperatures above room temperature, they can condense when they reach the QMS. The condensed material will continually build up in the QMS and cover the valve seats and aperture. Two approaches can prevent this problem: control the location of condensation or prevent condensation. The first approach can be very simple: place screens or metal plates before the inlet to provide sacrificial surfaces for condensation. The sacrificial surfaces should have good thermal connections to the outer walls so that they stay at room temperature. These surface will act like a trap and prevent the unwanted materials from passing into the QMS. The second approach involves operating the entire QMS inlet above the condensation temperature of the condensable material. This may be feasible if the operating temperature is below 100 °C. All the tubing components in the inlet can be heated to 100 °C or more. The electronics and pumps cannot operate at elevated temperatures. This approach (keeping the tubing hot and electronics cool) is a difficult task and therefore is not recommended.

Glossary

The following is a listing of some of the most important terms used throughout the SRS RGA Operations Manual. For a more complete listing of terms relevant to partial pressure analyzers in general, refer to:

“A Dictionary of Vacuum Terms used in Vacuum Science and Technology, Surface Science, Thin Film Technology and Vacuum Metallurgy”, edited by M. S. Kaminsky and J. M. Lafferty, published by the American Vacuum Society, 1979.

A. Basford et. al., J. Vac. Sci. Technol. A 11(3) (1993) A22-40: “Recommended Practice for the Calibration of Mass Spectrometers for Partial Pressure Analysis. Update to AVS Standard 2.3”.

Anode Grid (Ionizer Component): Positively biased grid cage of the ionizer within which the ionization of the gas molecules takes place. **Note:** In the SRS RGA, the voltage bias of the anode grid, in Volts, sets the ion energy (in eV) for the spectrometer.

Atomic mass unit (abbreviation: amu). A unit of mass equal to one twelfth the mass of a neutral carbon atom having six protons and six neutrons (^{12}C); equivalent to $1.660566 \cdot 10^{-27}$ kg.

Background signal, H_0 . Output signal, measured with respect to baseline, which is obtained before the introduction of any gas in the chamber.

Base pressure (also Background pressure). Total pressure before introduction of any gases into a vacuum system. Usually, the base pressure is the lowest pressure that is typically achieved in the vacuum chamber.

Baseline. The output signal from the RGA when no ions are arriving at the detector.

CDEM. Abbreviation for the type of electron multipliers known as: Continuous Dynode Electron Multiplier.

CF Nipple. A short section of vacuum pipe terminated with a standard Conflat flange connector at each end.

CF. Abbreviation for Conflat type flange.

Charge, Q . The electron charge of an ion. Ion charge occurs in multiples of the electron charge, e^- .

Cleanup time - is a measure of how quickly the response returns to zero when a gas is removed from the inlet (not necessarily equal to response time).

Delay time - is a measure of the time between when a step change is presented at the inlet and the response is first seen at the QMS (can be very long without degrading the response time).

Drift. A change in time in the average output signal at constant partial pressure.

ECU. Abbreviation for electronics control unit.

Electron emission current. The electron current from the filament to the grid in milliAmperes.

Electron emission. The release of electrons from the heated filament in the ionizer. The electrons are accelerated into the **anode grid** where the ionization of the gas molecules occurs.

Electron Energy. The kinetic energy of the electrons (in eV) used for electron bombardment in the ionizer. **Note:** In the SRS RGA the Electron Energy is equal to the voltage difference (in Volts) between the filament and the anode grid.

Electronics Control Unit (abbreviation: ECU). Electronics box that attaches directly to the probes feedthrough flange and contains all the necessary components to operate the quadrupole mass spectrometer and communicate with a host computer.

Faraday Cup. A charged particle detector, consisting of a metal electrode, for the direct collection and detection of charged particles. **Note:** Typical designs are cup shaped to minimize secondary electron losses.

Filament (Ionizer Component). The source of the ionizing electrons. Thin, thoria coated, Iridium wire that operates at a negative potential relative to ground and is resistively heated to incandescence with an electrical current from the emission regulator. The thermionically emitted electrons are accelerated towards the anode grid which is positively charged with reference to the filament and ground.

Focus Plate (Ionizer component). Ionizer's electrode plate that serves the double purpose of drawing the ions away from the anode grid, and containing the ionizing electrons inside the source.

Fragment ion. An ion of mass smaller than that of the original parent molecule.

Fragmentation (or cracking) pattern. The fragment distribution of ionic species which results from dissociation and ionization of multi-atomic molecules of given species in the ionizer.

Fragmentation factor. The fragmentation factor of gas g at mass M is defined as the ratio of ion signal at mass M to the ion signal at the principal mass peak of gas g .

Fragmentation of molecules: The breaking of multi-atomic molecules into units of fewer atoms, some of which are usually electrically charged.

Head (also RGA Head). The combination of the Probe and the Electronics Control Unit.

ID - inside diameter

Inert Gas. A gas that does not normally react chemically with other substances. Example: He, Ar, Kr and Xe. Typically used for calibration purposes in RGA's.

Ion current signals scale linearly with the electron emission current. **Note:** The available emission current range in the SRS RGA is 0 to 3.5 mA.

Ion current. The rate of ion flow into the detector. Usually expressed in units of amps.

Ion Energy. The kinetic energy of the ions as they move down the quadrupole mass filter, and expressed in eV. **Note:** In the SRS RGA the Ion Energy is equal to the voltage biasing of the anode grid in Volts and has two possible settings (i.e. Low and High).

Ion. An atom or molecule which has gained or lost one or more electrons and therefore has a negative or positive charge. Note: Most RGA's use electron bombardment to ionize molecules and detect only positive ions.

Ionization efficiency. The ionization probability normalized to the probability of ionization of a reference gas.

Ionization Potential. The minimum energy per unit charge (often in eV) required to remove an electron from an atom (or molecule) to infinite distance. **Note:** In the SRS RGA the Electron energy must be set above the ionization potential of the molecules for ionization to occur.

Ionization probability. The number of ion pairs (equal amounts of positive and negative charges appear as ions) produced by an electron traveling a unit distance (typically 1 cm) through a gas at unit pressure (typically 1 mTorr). It depends on the ionization potential of the electrons used for bombardment.

Ionization. The process that results in the formation of ions from neutral atoms or molecules. During ionization, electrons are added or removed from the molecules to form negative or positive ions respectively. **Note:** In the SRS RGA the ionization is caused by electron bombardment; outer electrons are removed by the impact of energetic electrons on the molecules.

Ionizer (Probe Component). The portion of the mass spectrometer probe that generates the ions and accelerates them as a beam. **Note:** The components of the SRS RGA ionizer are: anode grid, repeller, focus plate, and filament.

Linear response range. The partial pressure range over which linearity in the signal response is observed. See linearity.

Linearity. The extent to which the change in output signal of the RGA is proportional to the corresponding change in partial pressure.

Mass analyzer (Probe component). The portion of the mass spectrometer probe that separates the ion beam into its various mass-to-charge ratio components. Also referred to as Quadrupole mass filter.

Mass Number, M. The mass number, M, is the sum of the number of protons and neutrons in an atom or molecule.

Mass peak. The ion current pattern in the vicinity of maximum amplitude by scanning through a small portion of the mass range containing ions of a single mass-to-charge ratio. Very often, the term “mass peak” refers to the signal developed from singly charged ions. For example, nitrogen is said to have a “mass 28 peak”.

Mass Range. The range of mass numbers defined by the mass number of the lightest and the heaviest singly charged ions which can be detected by the RGA.

Mass spectrometer. An instrument which produces a beam of molecular ions from a sample, separates the resulting mixture of ions according to their mass-to-charge ratios, and provides output signals which are measures of the relative abundances of the ionic species present.

Mass spectrum. A graph of ion abundance vs. mass-to-charge ratio.

Mass-to-charge ratio: The mass-to-charge ratio, M/Q , is defined as the ratio of the mass number M of the ion to its charge Q, measured in units of the electron charge e^- . For example: doubly charged ions of argon isotope 36 ($^{36}\text{Ar}^{2+}$) and singly charged ions of water, $^1\text{H}_2^{16}\text{O}^{1+}$, have $M/Q = 18$, and

cannot be differentiated from each other with most mass spectrometers. **Note:** Mass spectrometers do not actually measure the molecular mass directly, but rather the mass-to-charge ratio of the ions. For singly charged ions, the mass to charge ratio is numerically equal to the mass of the ion in atomic mass units (amu).

Minimum Detectable Partial Pressure change (MDPP). The partial pressure change corresponding to the smallest signal change which can be distinguished from noise. A common prescription is, $\Delta p_{\min} = \sigma/S_g$, where σ is the noise and S_g is the partial pressure sensitivity for the gas being measured.

Noise. Random fluctuation in the output signal unrelated to a change in the partial pressure of the gas from which the signal is derived. The appropriate measure of noise is the standard deviation σ_N of N independent determinations of the average output signal obtained at constant partial pressure.

Open Ion Source (Also Nude Ion Source). An ionizer with electrodes of high transparency to gases.

Outgassing. The evolution of gas molecules from the internal wall surfaces of the vacuum system.

Parent ion. An ion of the same mass as that of the original parent molecule.

Partial Pressure Analyzer (abbreviation: PPA). A compact mass spectrometer used to analyze the residual gas composition in a vacuum system.

Partial Pressure. The pressure of a designated component of a gaseous mixture within a system as it is exerted on the chamber walls. The sum of the partial pressures of all the kinds of gases gives the total pressure.

Peak height (also peak intensity). The maximum ion signal developed in the RGA for a given mass-to-charge ratio peak.

Peak width ($\mathbf{DM}_{v\%}$). The difference between the mass-to-charge ratio values on either side of a mass peak at which the signal has dropped to $v\%$ of the peak height, H . See also Resolution.

Principal mass peak. The most intense peak in the fragmentation pattern of any molecule.

Probe (also RGA Probe). Quadrupole mass spectrometer sensor consisting of an ionizer, a mass analyzer and a detector (Faraday cup or optional electron multiplier).

QMS - quadrupole mass spectrometer

Repeller (Ionizer Component). The repeller grid cage completely encloses the ionizer, is biased negative relative to the filament, and prevents the loss of electrons from the ion source.

Residual Gas Analyzer (abbreviation: RGA). A compact mass spectrometer used to analyze the residual gas composition in a vacuum system (same as Partial Pressure Analyzer).

Resolution, or Absolute Resolution, $\mathbf{DM}_{10\%}$. The width \mathbf{DM} of the pass band of the filter, defined as the full width at which the ion current falls down to 10% of the maximum value. In mass-to-charge ratio units. See also Peak width.

Resolving Power: $R = M/\mathbf{DM}_{10\%}$: Ratio between a particular mass-to-charge ratio M and the resolution, $\mathbf{DM}_{10\%}$, at that mass. Dimensionless ratio.

Response time - is a measure of the steepness of the response when a step change is presented at the inlet.

RGA - residual gas analyzer (a class of QMS)

RGA Cover Nipple. CF Nipple that covers the RGA Probe.

Scan Speed (mass spectrometer). The speed at which the RGA scans through a range of successive mass numbers.

Scanning. The procedure of continuously changing the mass tuning of the quadrupole mass spectrometer to bring successive mass numbers into tune.

Sensitivity calibration. The act of establishing a correspondence between the change in ion current and the corresponding change in partial pressure of the gas from which the ion is produced. The correspondence might be represented graphically or as a table of values. See also Sensitivity.

Sensitivity.

Partial Pressure: The partial pressure sensitivity of the RGA to a gas g , S_g , is defined as the ratio of the change $(H-H_0)$ in principal mass peak height to the corresponding change $(P-P_0)$ in total pressure due to a change in partial pressure of the particular gas species. H_0 and P_0 are background values: $S_g = (H-H_0) / (P-P_0)$. The units of S_g are of ion current per unit pressure (amp/Torr, for example).

Total Pressure: The total pressure sensitivity of the RGA to a gas g , is defined similarly as the ratio of the change $(H-H_0)$ in total ion current to the corresponding change $(P-P_0)$ in total pressure due to a change in partial pressure of the particular gas species. H_0 and P_0 are background values.

Space charge. The electrical charge carried by a cloud of free electrons or ions. Space charge can cause serious changes in the potential distributions of the ionizer, and ultimately limits the pressure operating range of all RGA's.

STP. Standard temperature, 273.15 K, and pressure, 1.01325 bar, for gasses. Volume alone is insufficient to describe the flow of gasses. When temperature and pressure are also defined, the state is completely defined.

Total Pressure. The average normal force per unit area exerted by all the gas molecules impacting on the internal surfaces of the vacuum chamber. Units are typically Torr, mbar or Pascal. Note: The SRS RGA is capable of collecting total ion currents that can be turned into total pressure measurements with the help of gas dependent total pressure sensitivity factors.

UHV. Abbreviation for Ultra High Vacuum. Pressure $< 10^{-9}$ Torr.

References

General RGA information

Dawson, "Quadrupole Mass Spectrometry and Its Applications", AIP Press, NY, 1995.

Drinkwine and D. Lichtman, "Partial Pressure Analyzers and Analysis", AVS Monograph Series published by the Education Committee of the American Vacuum Society

Basford et. al., *J. Vac. Sci. Technol.*, A 11(3) (1993) A22-40: "Recommended Practice for the Calibration of Mass Spectrometers for Partial Pressure Analysis. Update to AVS Standard 2.3".

Batey, *Vacuum*, **37** (1987) 659-668: "Quadrupole Gas Analyzers"

Fu Ming Mao et. al., *Vacuum*, **37** (1987) 669-675: "The quadrupole mass spectrometer in practical operation"

Dawson, *Mass Spectrometry Reviews*, 5 (1986) 1-37: "Quadrupole mass analyzers: Performance, design, and some recent applications"

Vacuum Diagnosis

Studt, *R&D Magazine*, October 1991, p. 104: "Design Away Those Tough Vacuum System Riddles"

Applications of RGAs to process control

O'Hanlon, *J. Vac. Sci. Technol.* A 12 (4), Jul/Aug 1994: "Ultrahigh vacuum in the semiconductor industry"

Vic Comello, *R&D Magazine*, September 1993, p. 65: "Process Monitoring with "Smart" RGAs"

Waits, et. al., *Semiconductor International*, May 1994, p. 79: "Controlling your Vacuum Process: Effective Use of a QMA"

Rosenberg, *Semiconductor International*, October 1995, p. 149: "The Advantages of Continuous On-line RGA Monitoring".

Lakeman, *Semiconductor International*. October 1995, p. 127: "Increase overall Equipment Effectiveness with In Situ Mass Spectrometry".

Quantitative measurements

Bley, *Vacuum*, 38 (1988) 103-109: "Quantitative measurements with quadrupole mass spectrometers: important specifications for reliable measurements"

Cowen, et. al., *J. Vac. Sci. Technol.* A 12(1), Jan/Feb 1994: "Nonlinearities in sensitivity of quadrupole partial pressure analyzers operating at higher pressures"

Multiple linear regression analysis algorithms

William H. Press, et. al., 1992, *Numerical Recipes in C, The Art of Scientific Computing, Second Edition*, Cambridge Univ. Press, section 15.4, page 671.

Bevington, P.R., 1969, *Data Reduction and Error Analysis for the Physical Sciences*, New York, McGraw-Hill, Chapters 8-9.

Technical Reference Manual

QMS 100 Series Gas Analyzer



Certification

Stanford Research Systems certifies that this product met its published specifications at the time of shipment.

Warranty

This Stanford Research Systems product is warranted against defects in materials and workmanship for a period of one (1) year from the date of shipment.

Service

For warranty service or repair, this product must be returned to a Stanford Research Systems authorized service facility. Some components may be serviceable directly from the supplier. Contact Stanford Research Systems or an authorized representative before returning this product for repair.

Trademarks

Ultra-Torr[®], Swagelok[®] and VCR[®] are registered trademarks of Swagelok Co.

Tygon[®] is a registered trademark of Norton Co.

All other brand and product names mentioned herein are used for identification purposes only, and are trademarks or registered trademarks of the respective holders.

Information in this document is subject to change without notice.

Copyright © Stanford Research Systems, Inc., 1996, 2006, 2012. All rights reserved.

Stanford Research Systems, Inc.
1290-D Reamwood Avenue
Sunnyvale, California 94089
408 744 9040

Printed in USA

Table of Contents

Safety	iv
Specifications	v
Materials List	vii
Command List	viii
Chapter 1. Principles of Operation	1-1
Internal View	1-2
Overall System	1-3
Pressure Reducing Inlet	1-5
Capillary Design	1-10
Chapter 2. Quadrupole Spectrometer	2-1
Introduction	2-2
ECU	2-3
Electrometer	2-4
Mass Filter Power Supply	2-6
Ionizer	2-7
Quadrupole mass filter	2-11
Ion Detector	2-16
Chapter 3. Programming the RGA	3-1
Introduction	3-3
The RGA COM Utility	3-4
Command Syntax	3-5
Communication Errors	3-7
Programming the RGA ECU	3-9
RGA Command Set	3-25
Error Byte Definitions	3-64
Chapter 4. Trouble Shooting	4-1
System Problems	4-2
Internal Error Detection in the SRS RGA	4-4
Windows Software Error Codes	4-8
Chapter 5. Service	5-1
Warnings!	5-2
Component Notes	5-3
Accessing Internal Components	5-7
General Checks	5-11
Cleaning	5-13
Component Replacement	5-20
Replacement Parts	5-28
Factory Service	5-29
Appendix A. System Electronics	A-1
Description of Schematics	A-2
Parts List	A-4
Appendix B RGA Circuit Description	B-1
Overview of the RGA	B-3
Circuit Description	B-4
Description of Schematics	B-6
Parts Lists	B-18
Appendix C. Drawings & Schematics	C-1

Safety

Line Voltage

The QMS system is specified for power line of either 110 V / 60 Hz or 220 V / 50 Hz. The diaphragm pump will only operate on the specified voltage. Operating at other voltages will damage the motor. For 110 V operation use one 3 A fuse. For 220 V operation, two 1.5 A fuses must be used in the power entry module.

Exhaust

As shipped, the QMS system exhausts to the atmosphere. If the system is analyzing hazardous gases, the user must make provisions to handle the exhaust from the system. A standard 1/4 inch connection is provided for this purpose.

Ventilation

The QMS system **requires** forced air cooling to operate at a reasonable temperature. Do not block the air inlet or exhaust on the back of the unit. Components will fail without this cooling.

Elastomer Seals

Silicone has been reported to react adversely and irreversibly with the glass contained in an electron multiplier. In systems containing an RGA w/electron multiplier, do not use silicone greases or oils on seals; use only hydrocarbon based materials.

Lifting

The QMS system is heavy. Two people are recommended for lifting the system. The handle is provided for occasional use and short periods. Do not hoist or hang the system by the handle.

Specifications

Inlet

Type	capillary: available in stainless steel, PEEK, and glass lined plastic
Flowrate	1 to 10 milliliter per minute at atmospheric pressure
Response time	<400 ms
Pressure	selectable from 10 mbar to 1 bar

Mass Spectrometer

Operational:

Mass filter type	Quadrupole (Rod diameter: 0.25", rod length: 4.5")
Detector type	Faraday cup (FC) - standard Electron multiplier (CDEM) - optional
Resolution (per AVS standard 2.3).	Greater than 0.5 amu @ 10% peak height Adjustable to constant peak width throughout the entire mass range.
Sensitivity (A/Torr)*	$2 \cdot 10^{-4}$ (FC) <200 (CDEM). User adjustable throughout high voltage range.
Minimum detectable partial pressure (MDPP)*	$5 \cdot 10^{-11}$ Torr (FC). $5 \cdot 10^{-14}$ Torr (CDEM). * Measured with N ₂ @ 28 amu with 1 amu full peak width @ 10% height, 70 eV electron energy, 12 eV ion energy and 1 mA electron emission current.
Operating pressure range	10^{-4} Torr to UHV (FC) 10^{-6} Torr to UHV (CDEM)
Max. bakeout temperature (without ECU)	350 C (FC) 300 C (CDEM)

Recommended bakeout temperature 100 - 250 C

Ionizer:

Design Open ion source. Cylindrical symmetry
Operation Electron impact ionization.
Material SS304 construction
Filament Thoriated Iridium (dual) with firmware protection. Field replaceable.
Degas 1 to 10 W Degas ramp-up.
Electron energy 25 to 105 V, programmable.
Ion energy 8 or 12 V, programmable.
Focus voltage 0 to 150 V, programmable.
Electron emission current 0 to 3.5 mA, programmable.

System

Pumps hybrid turbomolecular/drag pump, 70 liter/s, ultimate pressure 2×10^{-9} mbar
diaphragm pump with ultimate pressure less than 1 mbar
protection class IP44

Materials construction: SS304 and SS316
(see full materials list for details) insulators: alumina, ceramic
seals: Viton, buna-N, and nitrile butyl rubber
misc: aluminum, Tygon

General

Startup time 2 minutes from full stop
Max. Ambient Operating Temperature 35 °C
Power requirement either 110 V / 60 Hz or 220 V / 50 Hz (not field selectable) less than 600 W total
Dimensions 44 cm H × 20 cm W × 61 cm D (17 in H × 8 in W × 24 in D)
Weight 34 kg (75 lb.)

Materials List

SRS receives many requests for information about corrosion compatibility. It is our policy not to state the compatibility of our system with various corrosive environments. We simply cannot test the myriad combinations of environments that our customers use.

We do provide a list of *all* the materials exposed to the gas being introduced into the system. Our expectation is that users who need to measure corrosive environments already have some type of system that creates, handles and contains the corrosive gases. Given that they have designed and operate said system, they are the best people to decide the compatibility of the materials in our system with the specific corrosive environment.

The QMS system contains the following materials:

Body

- 304 stainless steel - high vacuum tube
- 316 stainless steel - quarter inch tube and fittings
- molybdenum - electrical feedthrough
- ceramic - electrical feedthrough
- AgCuIn - braze material on feedthroughs
- alumina - contained in the spectrometer
- aluminum - body of diaphragm pump

Replaceable Components

- glass - body of electron multiplier
- chromium - surface of the electron multiplier
- IrO₂·ThO₂ - filament of analyzer (can be substituted with tungsten)

Seals

- copper - seals in the CF high vacuum flanges
- 316SS - major component of VCR[®] seals
- silver - a thin layer on the VCR[®] seals to prevent gauling
- Viton - o-ring seal in the inlet fitting (can be substituted)
- buna-N - seals in the valves
- neoprene - diaphragms in diaphragm pump
- nitrile butyl rubber(NBR) - diaphragm pump valves - backing line
- Tygon[®] - exhaust from diaphragm pump (can be substituted)

Command List

Initialization

Name	Description	Parameters	Echo
ID	Identification Query	?	ID String
IN	Initialization	0,1,2	STATUS Byte

Ionizer Control

Name	Description	Parameters	Echo
DG	Degas Ionizer	0-20, *	STATUS Byte
EE	Electron Energy	25-105, *, ?	STATUS Byte or query response
FL	Electron Emission Current	0-3.50, *, ?	STATUS Byte or query response
IE	Ion Energy	0, 1, *, ?	STATUS Byte or query response
VF	Focus Plate Voltage	0-150, *, ?	STATUS Byte or query response

Detection Control

Name	Description	Parameters	Echo
CA	Calibrate All	none	STATUS Byte
CL	Calibrate Electrometer	none	STATUS Byte
HV	CDEM's High Voltage	0-2490, *, ?	STATUS Byte or query response
MO	Multiplier Option	?	CDEM option
NF	Noise Floor	0-7, ?	Query response

Scan and Measurement Control

Name	Description	Parameters	Echo
AP	Analog Scan Points	?	Query response
HP	Histogram Scan Points	?	Query Response
HS	Histogram Scan Trigger	0-255, *, none	Ion Currents
MF	Final Mass	1-M_MAX, *, ?	Query response

MI	Initial Mass	1-M_MAX, *, ?	Query response
MR	Single mass measurement	0, M_MAX	Ion Current
SA	Steps per amu	10-25,*,?	Query response
SC	Analog Scan Trigger	0-255,*, none	Ion Currents
TP	Total Pressure measurement	0, 1, ?	Ion Current

Parameter Storage

Name	Description	Parameters	Echo
MG	CDEM gain storage	0.0000-2000.0000,?	Query Response
MV	CDEM Bias Voltage storage	0-2490, ?	Query Response
SP	Partial Pressure Sensitivity	0.0000-10.0000,?	Query response
ST	Total Pressure Sensitivity	0.0000-100.0000, ?	Query response

Mass filter control

Name	Description	Parameters	Echo
ML	Mass Lock	0.0000-M_MAX	none

Tuning

Name	Description	Parameters	Echo
CE	Calibration Enable Query	?	Query response
DI	DI parameter (Peak Width Tuning)	0-255, *, ?	Query response
DS	DS parameter (Peak Width Tuning)	-2.5500-2.5500, *, ?	Query response
RI	RF_Driver @0 amu (Peak Position Tuning)	-86.0000-86.0000, *, ?,none	Query response
RS	RF_Driver @ 128 amu (Peak Position Tuning)	600.0000-1600.0000, *, ?,none	Query response

Error Reporting

Name	Description	Parameters	Echo
ER	STATUS Byte Query	?	Query response
EP	PS_ERR Byte Query	?	Query response

ED	DET_ERR Byte Query	?	Query response
EQ	QMF_ERR Byte Query	?	Query response
EM	CEM_ERR Byte Query	?	Query response
EF	FIL_ERR Byte Query	?	Query response
EC	RS232_ERR Byte Query	?	Query response

Note: M_MAX= 100 for RGA100, 200 for RGA200 and 300 for RGA300.

Chapter 1.

Principles of Operation

The QMS consists of two main subsystems: the gas handling inlet and the mass spectrometer. These two subsystems operate independently of each other. The gas handling subsystem delivers the sample to the spectrometer chamber. It has no control of the spectrometer or communications with it. The spectrometer only analyzes the sample. It has no knowledge of the pressure reduction or the gas handling subsystem. This chapter describes the overall instrument and the components that are responsible for delivering the sample gas to the mass spectrometer. The next chapter contains a detailed discussion of the spectrometer.

In This Chapter

Internal View	1-2
Overall System.....	1-3
Power.....	1-3
Controller	1-3
Structure.....	1-4
Exhaust.....	1-4
Pressure Reducing Inlet	1-5
Flow Calculations	1-6
Diaphragm Pump	1-8
Turbo Pump	1-9
Capillary Design	1-10
Length & Bore.....	1-10
Materials and Fittings	1-12
Extensions.....	1-13

Internal View

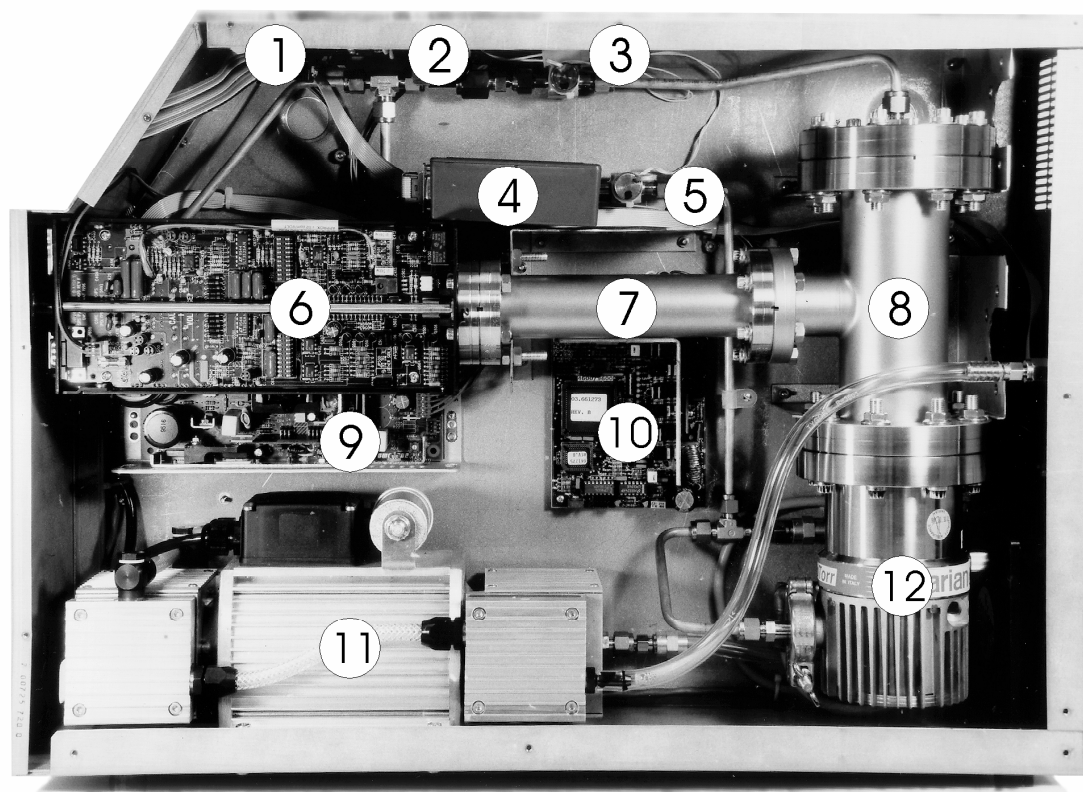

Figure 1. Main components of the QMS are labeled:

- 1. microcontroller
- 2. aperture
- 3. sample valve
- 4. pressure gauge
- 5. bypass valve
- 6. quadrupole electronics
- 7. mass spectrometer
- 8. analyzer chamber
- 9. 24V power supply
- 10. turbo pump controller
- 11. diaphragm pump
- 12. turbo pump

Overall System

The QMS was designed to be a self contained instrument. Only line power is required to operate the instrument. One serial cable between the instrument and a computer is required to run the software. No ancillary gas supplies are necessary.

Power

Internally the QMS uses line power (110 or 220) and 24 VDC. The line power is distributed to the 24 V power supply and a relay connected to the diaphragm pump. When the main power switch is turned on, 24 V becomes available throughout the instrument. The turbo pump, spectrometer, control electronics and fan use 24 V. The fan will operate whenever the main power switch is on.

Whenever main power is on, the mass spectrometer is active. As soon as the instrument is powered, programs can communicate with the spectrometer. If the pumps have not been activated, then only a limited number of the spectrometer's commands will be operable. Most commands, *e.g.* turn on the filament, will only work when the pumps are active. The identification command (ID?) can be used to determine the presence of an active spectrometer. Because the spectrometer uses hardware handshaking, programs can also check the serial port to determine the presence of an active spectrometer.

The microcontroller is active as soon as the main power is on. It has control of the two pumps, two valves, and the front panel.

Controller

The two valves and two pumps are directly controlled by the microcontroller. The microcontroller considers the four switches on the front panel to be requests to turn on or off the associated component. The rules programmed into the controller determine whether the request will be performed or rejected.

The two valves are actuated with 24 V solenoids, which are normally closed. The controller sends these valves power when they need to be opened. The valves can only be fully open or fully close. To limit the sudden inrush of high pressure gas when the capillary flow is started, the controller opens the valve in short pulses.

A three phase motor drives the turbo pump. A separate turbo pump control board synthesizes the motor drive from the 24 V supply. The microcontroller sends a signal to the turbo pump control that indicates on or off. The turbo pump control responds with a signal that indicates that the pump is at full speed, which the microcontroller monitors. The turbo pump control also outputs a current monitor that indicates how much power the pump is consuming. This signal is displayed on the front panel as a rough indicator of the pump power. The display is not intended to be analytic.

The diaphragm pump operates on line power. The microcontroller actuates the relay to turn the pump on or off.

The pressure gauge operates on 15 VDC, which is provided by the microcontroller. The gauge has on-board electronics that provide a setpoint comparison. The setpoint check is used by the microcontroller to determine if the system is operating acceptably. The gauge also outputs an analog signal related to the pressure. This signal is displayed on the front panel. The output of the gauge is not linear, and thereby the spacing of the numbers on the display is irregular. The front panel display is too coarse to be used analytically.

Structure

The QMS is built with a thin aesthetic skin surrounding a structural steel chassis. Figure 1 shows the instrument with the skin, bezel, and main side panel removed. (The Service chapter discusses dis-assembly.)

As seen in Figure 1, most of the components are attached to the left wall of the chassis (as viewed from the front). Because of this, if the instrument is to be laid on its side, the left side is preferred; the weight of the components is directly supported.

For mounting the instrument, the feet and handle can be removed. The threaded inserts provide convenient mounting locations. The handle holes accept 1/4-20 bolts and the feet accept 6-32 screws. Note that the inserts only support tension; they will push-out if large thrust loads are applied. Do not permanently hang the instrument from the handle mounts, support the weight from the bottom. There are components behind the threaded inserts. Do not use screws that extend more than 1/2 inch into the chassis.

Exhaust

The exhaust connection on the back panel is provided for handling hazardous gases. The connection is a 1/4 inch Swagelok tube stub. The slight indent is intended to provide a perfect seal to other Swagelok tube fittings. Use with other brand tube fittings cannot be recommended.

The exhaust can also be used to operate the QMS in a closed loop configuration, *i.e.* the exhaust stream is returned to the supply. The closed loop operation is feasible because the QMS does not significantly change the sample gas. The amount of the sample that is ionized by the mass spectrometer is microscopic, less than 1 nanoliter per minute (STP). The ionizer produces a microscopic amount of CO₂, typically less than 50 nanoliters per minute (or 26 ml per year). No air leaks into the system and no carrier or detector gases are added to the sample. Applications like glove box monitoring are well suited to closed loop operation, because the instrument does not require a continuous bleed from the box.

Pressure Reducing Inlet

The gas handling subsystem is designed to achieve several goals:

- reduce the pressure of the sample gas to the operating range of the mass spectrometer ($<10^{-5}$ mbar)
- provide a quick response time to changes of sample composition at the inlet
- allow for easy connection to system being measured
- use conventional materials

If only the first goal were important a single stage pressure reduction would be suitable.

For example, about 50 cm of 50 μm capillary would perform the required pressure reduction. In a single stage design, all the gas that enters the capillary is delivered to the spectrometer chamber. For a 70 l s^{-1} pump, the flowrate at the capillary inlet is 70 ml s^{-1} ! The velocity of the gas near the capillary inlet is very small. To demonstrate, the figure at the right shows the end of a 1/16 OD capillary and a hemi-spherical boundary of the same diameter. The time it would take to drain the volume inside the boundary is a measure of the response. For the small volumetric flowrate in this example, it would take 30 seconds to drain the tiny volume. This low speed implies that the capillary relies on diffusion or forced convection to respond to concentration changes.

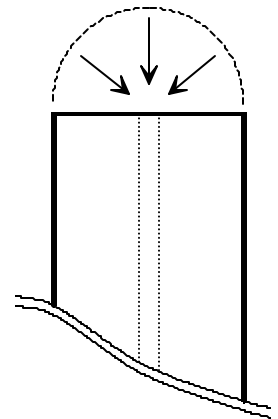

The effect of a low flowrate on leak detection is catastrophic. Imagine trying to locate a leak by moving the capillary tip around a fitting on a gas line. With the capillary in the example above, you could be 1/16 of an inch away from the leak source and not detect it for 30 seconds. To locate the leak, you would either have to move incredibly slow, or be exactly at the leak.

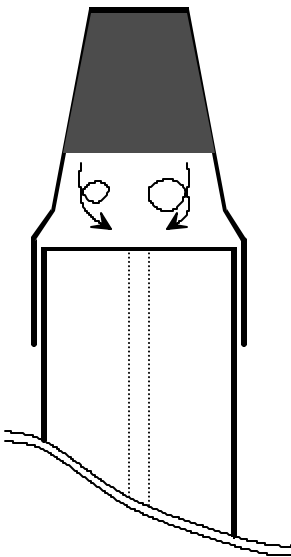

Low flowrates also severely restrict the inlet. At the left is shown a capillary with a syringe tip filter installed. The gap between the filter element and the end of the capillary (about 1/16 inch in this example) creates a dead volume. If this volume is approximated to be well mixed, the time constant is over 5 seconds. The time constant relates to the rate at which a system responds to a step change and is characterized by the familiar $1 - \exp[-t/t_c]$ response. In this example, a sudden change outside the filter would not be completely detected for over 15 seconds.

To achieve fast response, the QMS uses a bypass flow configuration, which draws 200-1000 times larger flowrates through the capillary. The same amount of sample is delivered to the spectrometer. As the name implies, most of flow is bypassed around the spectrometer. Also the pressure drop across the capillary is now only a factor of 1000 (as opposed to 1 billion). This means the capillary can either have a larger bore or be shorter than in a single stage system. The lower pressure drop makes feasible many capillary materials commonly used in gas chromatography. The following sections discuss details of the flow of the sample gas within the instrument.

Flow Calculations

The pressure and flowrates of the sampled gas can be calculated with simple formulas. The calculations here assume that gases behave ideally, which is a reasonable approximation at the temperatures and pressures involved. Actual system performance compares well with these simple calculations.

The pressure drop across a length of tube is related to the flowrate and dimensions by:

$$Q = C(P_{in} - P_{out}) = C \Delta P \quad (1)$$

where Q is the throughput, C is the conductivity, and ΔP is the pressure drop. Throughput is a measure of mass flowrate commonly used in vacuum systems. Typical units for Q are mbar liter s^{-1} , which unless stated otherwise, implies a standard temperature. At STP (273.15 K and 1013.25 mbar) 1 mbar liter s^{-1} is equal to 1.013 $cm^3 s^{-1}$ (sometimes abbreviated sccs). The conductivity of various geometries is calculated with the standard formulas available in texts discussing vacuum (see References).

The pressures and flow at every point in the system is determined by applying equation 1 to each section of tube. A simplified flow schematic of the QMS is shown below.

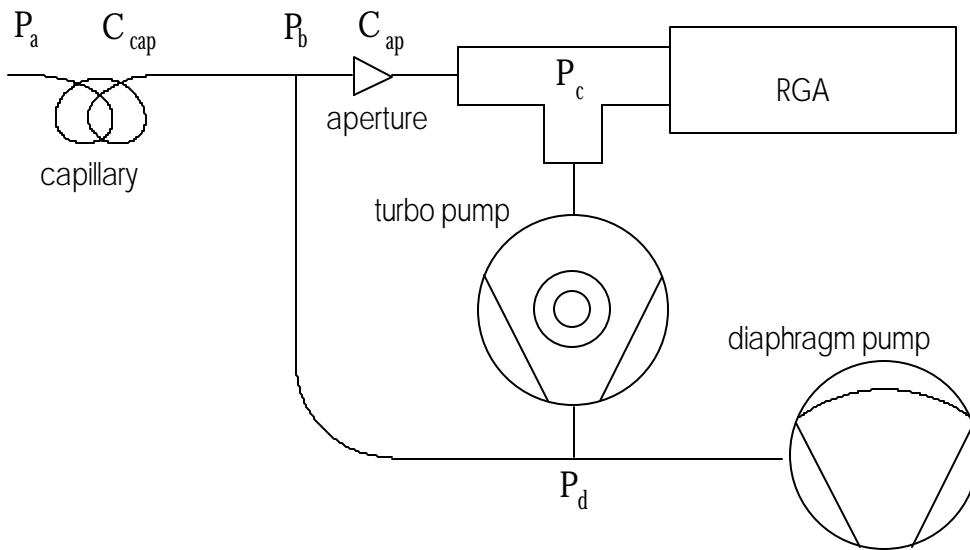

Figure 2. Schematic of key components of system.

For this example there are four points at which the pressure is unknown, P_a , P_b , P_c , and P_d . Applying equation 1 between each pair of points will yield a set of equations to solve. First all the sampled gas flows through the capillary:

$$Q_{total} = C_{cap} (P_a - P_b) \cong C_{cap} P_a \quad (2)$$

Because $P_a \gg P_b$, the approximation can be made. When the flow reaches the tee it is split into two streams, bypass and sample. The sample flow is a small fraction of the total flow, so we can assume that the bypass flow is equal the total and write the equation from the tee to the diaphragm pump as:

$$Q_{total} = C_{bd} (P_b - P_d) \quad (3)$$

where C_{bd} is the conductivity of the tube from the tee to the diaphragm pump. The flow through the aperture is:

$$Q_{sample} = C_{ap} (P_b - P_c) \cong C_{ap} P_b , \quad (4)$$

where again the large pressure drop allows the approximation to be used. The turbo pump is an active component that is characterized by

$$P_c = Q_{sample} / S , \quad (5)$$

where S is the speed of the pump and has the same units as conductivity (liter s^{-1}). For the pump in the QMS, the speed is a constant at 70 liter s^{-1} (except for He and H_2). Lastly, the diaphragm pump equation is

$$P_d = Q_{total} / S_{DP} . \quad 6$$

The speed of the diaphragm pump is not a constant; it is a function of the inlet pressure. A typical speed curve is shown in the graph below.

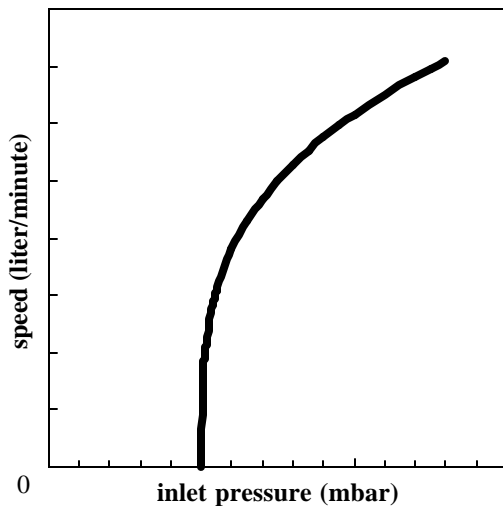

Figure 3. Speed curve for a diaphragm pump.

The curve shows an important feature: the speed goes to zero at a finite pressure. This pressure is the ultimate pressure of the pump. At this pressure, gas travels backward through the pump at the same speed at which it is being pumped forward. Therefore, even though the pump is still operating, it effectively has no speed.

Equations 2 to 6 completely describe the system. Solution of the entire set would determine all the unknowns, except that there are more unknowns than equations. Typically, the inlet pressure is known and the desired pressure at the spectrometer is known. The tubing dimensions determine C_{bd} leaving 6 unknowns. To simplify the calculations, P_d is chosen to be an acceptable value and the remaining values are solved for.

These equations demonstrate some important characteristics of the QMS.

- The pressure in the spectrometer chamber is directly proportional to the pressure at the exit of the capillary and largely controlled by the aperture. Choosing a different aperture has insignificant effect on the remainder of the system.
- The mass flowrate through the capillary is insensitive to changes in pressure at the exit of the capillary. This characteristic is very helpful to predicting the performance of different capillaries. If this were not true, the exit pressure of the capillary would be complexly related to the speed curve of the diaphragm pump. (This can happen when designing capillaries for low pressure).
- The pressure at the exit of the capillary is dominated by the speed curve of the diaphragm pump and the mass flowrate through the capillary.

These last two characteristics greatly simplify the selection of alternate capillaries and is discussed later in this chapter.

Diaphragm Pump

A measured speed curve for the diaphragm pump is shown in the figure at the right. The speed is the volumetric flowrate at that pressure. Because mechanical pumps have much lower flowrates than turbo pumps, the speed is usually expressed in volume per minute. A pressure of 1 mbar is a typical operating point for the QMS, which means the pump speed is 1.5 liter min^{-1} . The mass flowrate at the diaphragm pump and capillary inlet are the same. At the higher pressure of the capillary inlet, 1000 mbar, the corresponding volumetric flowrate is 1.5 milliliter min^{-1} . The simple relation

$$P_1 V_1 = P_2 V_2$$

is a good approximation as long as temperature is constant. The speed is 2.6 liter min^{-1} at 5 mbar, which corresponds to 13 milliliter min^{-1} at 1000 mbar. The turbo pump only operates with exhaust pressures up to approximately 5 mbar, which limits the useful range to that shown in Figure 4. Thereby, capillaries are always chosen to draw volumetric flowrates of 1-10 ml min^{-1} . The complete speed curve would keep increasing up to the pumps specification of 13 liter min^{-1} at atmospheric pressure.

The ultimate pressure of the diaphragm pump can age, mainly by degradation of the valve seats. This aging will shift the zero intercept of the speed curve (Figure 4) to higher pressures. For many operating pressures the effect is minimal, but pressures near the ultimate pressure will show drastic speed changes. The implication is that operating the QMS near the ultimate pressure of the diaphragm pump requires careful monitoring and should be avoided when feasible.

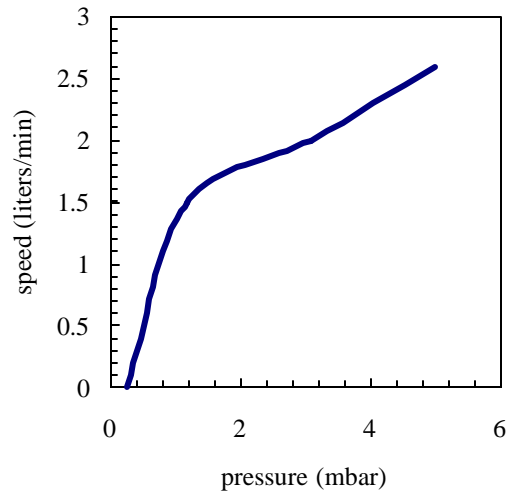

Figure 4. Measured pumping speed vs. the pressure at the pump inlet for the pump in the QMS.

Turbo Pump

The pump attached to the spectrometer chamber is hybrid turbomolecular/drag pump. The hybrid design of this pump allows it to exhaust at high pressure (relative to conventional turbomolecular pumps). The pumping speed is constant at the nominal value of 70 l s^{-1} over a large range of exhaust pressures. As the exhaust pressure approaches the maximum value, the speed begins to drop. Figure 5 shows a representative turbo pump speed curve, overlaid with the speed curve of the diaphragm pump. The two curves overlap for a small region of pressures, which determine the operating range of the system.

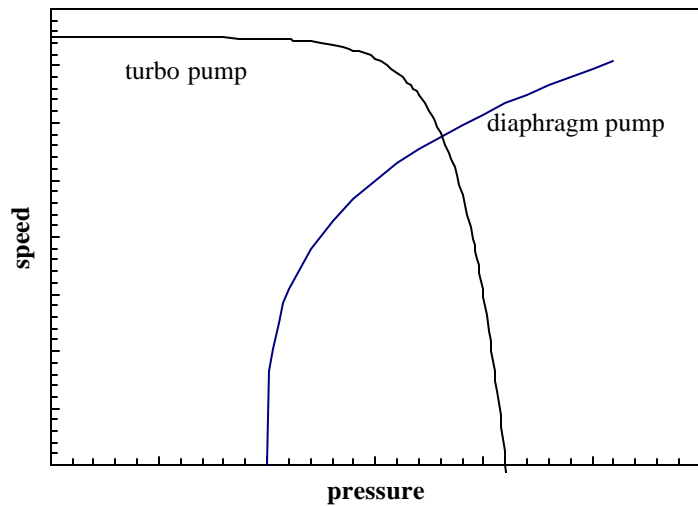

Figure 5. Representative speed curves for two pumps. The speed values have been scaled to show both pumps on the same graph. The pressure is the exhaust of turbo and the inlet of the diaphragm pump.

In the case the QMS, the overlapping region is 1-5 mbar. As the turbo pump exhaust pressure increases approaches 5 mbar, the work it performs will increase. The current monitor display on the front panel is a good indicator of the power consumed by the pump. Running the pump near its limit mainly causes the bearing temperature to increase. The turbo pump controller will detect if the bearings are overheating and avoid damage by shutting down the pump. Long term operation near the temperature limit mainly will age the bearings more quickly. The only advantage to operating the turbo pump at higher exhaust pressures is an increase in the flow rate through the capillary. The higher flowrate can help response time, but given the cost of a turbo pump rebuild, response time is better addressed through capillary design.

Capillary Design

The inlet uses a bypass configuration that results in a fast response time. A large flow is drawn through the capillary tube, which drops the pressure 3 decades. The typical capillary used at atmospheric pressure has a bore diameter of 0.125 mm and a length of 0.7 m. Any number of combinations of length and bore diameter can achieve the same flowrate and pressure drop. Capillaries are available in several materials. The factors affecting the choice of capillary are:

- inlet pressure
- required response time
- distance to sample point
- material restrictions
- cost

The possibilities for capillary choice are numerous, and SRS offers only a few types. The standard capillary shipped with the QMS is mainly provided to test the system and provide a reference. The following sections contains some guidelines to designing a capillary suited to the users application.

Length & Bore

To choose the dimensions of the capillary, three parameters must be fixed: the inlet pressure, exit pressure, and flowrate. These three values allow the conductivity to be determined (equation 1). A typical design point is an exit pressure of 1-2 mbar and a corresponding flow rate of 1.5 to 3.5 milliliter min^{-1} (see figure 4). The inlet pressure is determined by the users application. The capillary conductivity is a function of the geometry, pressure, temperature, and gas properties. A common formula for air flowing through a tube at 20°C is

$$C = 135 \frac{d^4}{L} \frac{P_1 + P_2}{2} , \quad (7)$$

where C is the conductivity in l s^{-1} , d and L are in cm, and the pressures are in mbar. More general formulas including temperature and viscosity are contained in the texts listed in the references. This formula also assumes laminar flow.

There are many approximations used in equation 7 and users may be concerned about its accuracy. The formula shows that the conductivity is a strong function of diameter. As a practical consequence, this strong dependence means the standard manufacturing tolerances on bore diameters will cause more uncertainty than the formula itself. A typical 0.005 inch bore capillary might have a $\pm 10\%$ tolerance. While it is reasonable that the bore could vary from 0.0045 to 0.0055 inch, this uncertainty causes the conductivity to vary by about $\pm 40\%$. Use the standard formulas as a guide, but cut the capillary long to begin with. Measure the actual performance and trim as necessary.

The chromatography industry uses a large variety of capillaries, from which we can select capillaries for the QMS. The figure below shows the conductivity for several commonly available bore diameters.

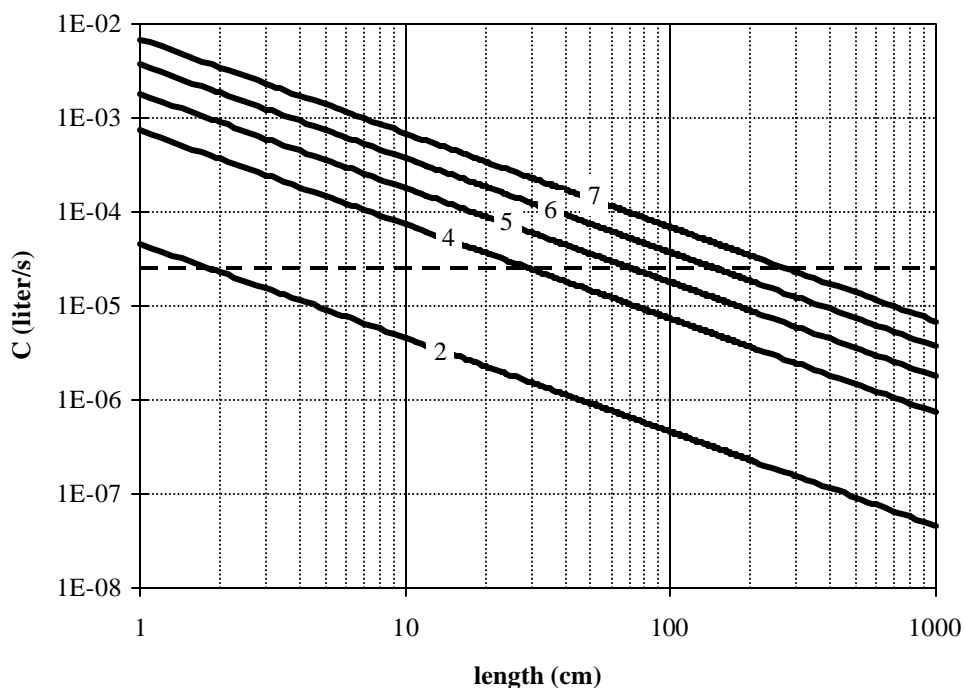

Figure 6. Conductivity of five different capillaries as a function of length. The curves are labeled with the bore diameter in thousandths of an inch. Both axis are logarithmic.

As an example, consider a capillary for atmospheric pressure and an capillary exit pressure of 1 mbar. From the speed curve for the diaphragm pump, the throughput, Q , is 2.5×10^{-2} mbar liter s^{-1} ($Q = P S$) and the required conductivity is 2.5×10^{-5} liter s^{-1} . The horizontal dotted line in figure 6 shows that for each capillary diameter there is an appropriate length. The application dictates which bore diameter is appropriate. If the system being measured was far away from the QMS, 3 meters of the 7/1000 capillary would be best. On the other hand, for something close 0.7 meters of 5/1000 would be less expensive. The gas velocity through the capillary quickly reaches the speed of sound. Thereby, until the capillary becomes **very** long, it is not an important contributor to the response time of the QMS.

Materials and Fittings

Users will find vendors of gas chromatography supplies a good source for capillaries and fittings. Capillaries are available in many materials. No material is ideal for all applications. The following table list features of several materials

material	min. bore diameter	advantages	disadvantages
stainless steel	0.005 in	<ul style="list-style-type: none">· rugged· high temperature· durable connections	<ul style="list-style-type: none">· difficult to cut without clogging the bore· marginal flexibility
PEEK	0.005 in	<ul style="list-style-type: none">· highly flexible· can be cut by user	<ul style="list-style-type: none">· weaker connections
glass lined plastic	0.002 in	<ul style="list-style-type: none">· smallest bore	<ul style="list-style-type: none">· cost· not flexible· low temperature

Three conventional methods are available for making connections to the capillaries: metal compression fittings, graphite seals, and o-ring seals. Metal compression fittings are suitable for stainless steel tube. The steel is capable of deforming to make the seal. The outside diameter of plastic capillaries is not round enough to make a good seal to metal ferrule. Graphite ferrules in a metal fitting are a better choice. The graphite will conform to any irregularities in the surface of the capillary. In addition, the graphite ferrule does not permanently deform the capillary as a steel ferrule would. O-ring seals, *e.g.* Ultra-Torr, make good seals. They only lack in the ability to operate at high temperature.

Extensions

As discussed in the previous section, the capillary can be designed to any length necessary by choosing an appropriate bore diameter. The cost of material might warrant the use of an extension of another material, *e.g.* common vinyl tubing. This can be accomplished as long as the extension is added to the vacuum side of the capillary:

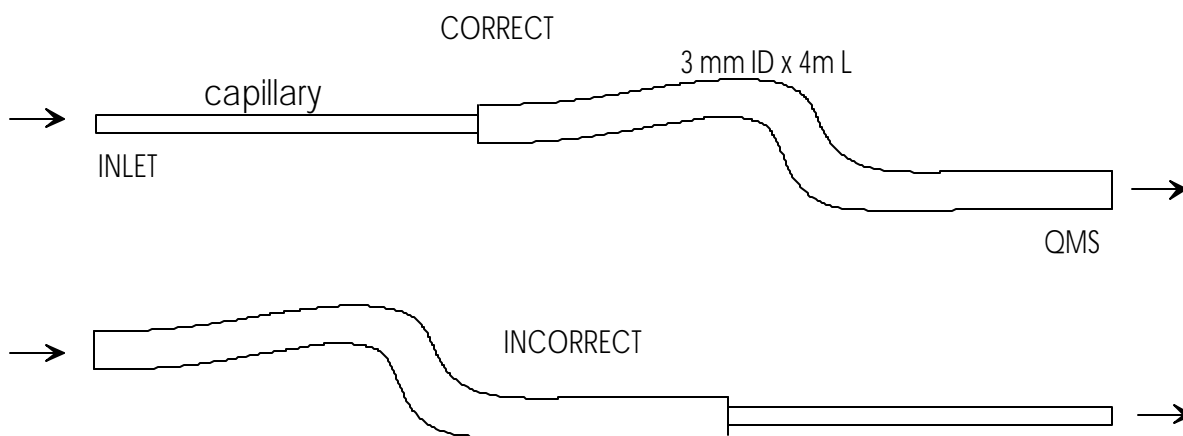

Figure 7. Good and bad methods of adding an extension of vinyl tubing to the capillary.

The incorrect approach above will destroy the response time of the instrument. At 1 ml per minute, it would take 33 minute for gas to travel from the inlet to the QMS. The correct approach would take less than 2 seconds. The decrease in pressure causes the volumetric flowrate to increase 1000 times as the gas travels through the capillary. The flow in the extension is viscous, which implies that only diffusion will cause mixing in the axial direction. Sudden changes in composition at the inlet will be detected as sudden changes at the QMS. The response is simply delayed by the amount of time it takes to traverse the extension. Only very long extensions should show any mixing. For extensions, the general rule is to get the beginning of the capillary as close to the sampling point as possible.

Chapter 2.

Quadrupole Spectrometer

This chapter describes the design and principles of operation of the components of the RGA quadrupole probe.

In This Chapter

Introduction	2-2
ECU.....	2-3
RS232/DCE/28.8k Connector.....	2-3
Calibration Lockout.....	2-3
Electrometer.....	2-5
Detection limit vs. scan rate.....	2-5
Adjusting the Zero of the Ion Detector.....	2-6
Mass Filter Power Supply	2-7
Ionizer.....	2-8
Description	2-8
Principle of operation.....	2-9
Parameter Settings.....	2-10
Quadrupole mass filter.....	2-12
Description	2-12
Principle of operation.....	2-13
Mass Range, Resolution and Throughput.....	2-14
Zero Blast Suppression	2-16
Ion Detector.....	2-17
Description	2-17
Faraday Cup operation	2-18
Electron Multiplier Operation	2-18

Introduction

The SRS RGA is a mass spectrometer consisting of a quadrupole probe, and an Electronics Control Unit (ECU) which mounts directly on the probe's flange and contains all the necessary electronics for operating the instrument.

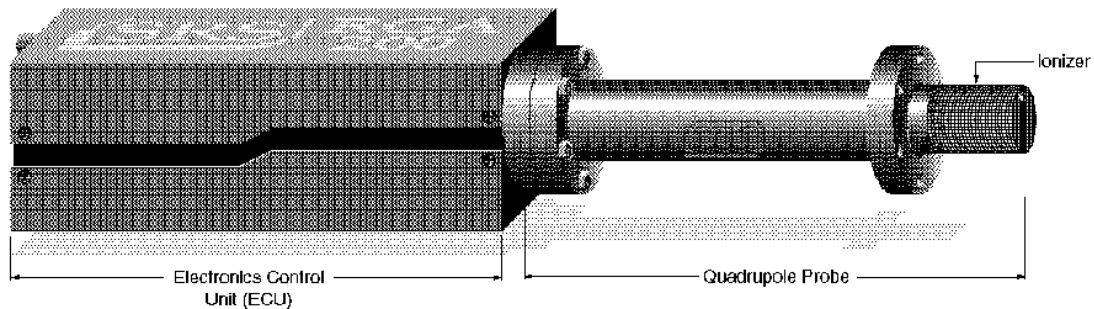

Figure 1 Quadrupole Head Components

The probe is a specially engineered form of quadrupole mass spectrometer sensor. It is mostly constructed out of type 304 stainless steel and high purity alumina. It analyzes residual gases ionizing some of the gas molecules (positive ions), separating the resulting ions according to their respective masses and measuring the ion currents at each mass.

The total probe equipment consists of three parts: the ionizer, the quadrupole filter and the ion detector. All of these parts reside in the vacuum space where the gas analysis measurements are made.

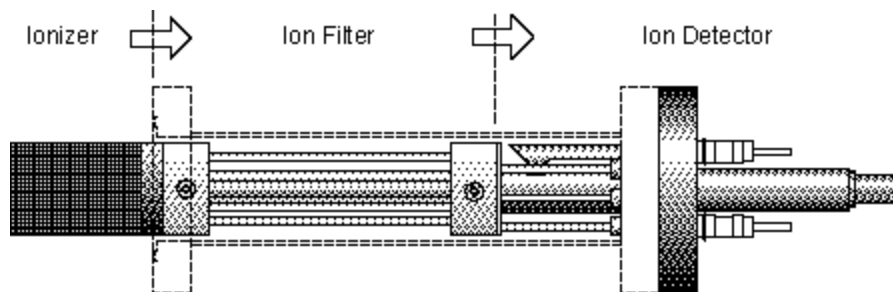

Figure 2 Probe Components

A stainless steel tube (RGA cover nipple) covers the probe assembly with the exception of the ionizer. A high vacuum environment (10^{-4} Torr or less) is required for operation.

ECU

Independently from the gas handling subsystem, the ECU completely controls the operation of the spectrometer, handles its data and transmits it to the computer for analysis and display.

The ECU is a densely packed box of electronics (3"x4"x9") that connects directly to the probe's feedthru-flange and also to a host computer. It includes several regulated power supplies, a built-in microprocessor, control firmware, and a standard RS232 communications port. It is powered by either the external 24VDC (@2.5Amps) power supply.

Warning

The ECU does not have any serviceable parts and does not require any routine maintenance. All calibration procedures should be done using the RS232 interface and the RGA calibration command set.

During normal operation of the RGA, regulated power supplies built into the ECU set the electron emission current, the voltage levels on the ionizer electrodes, and the high voltage across the electron multiplier. RF/DC levels for each mass are also set and regulated by the ECU, based on internal mass calibration parameters permanently stored in non-volatile memory. A built-in, logarithmic electrometer detects the ion currents collected by the FC, or electron multiplier, and converts them to voltage signals that are read by a built in A/D converter. The microprocessor automatically compares those signal voltages against an internal calibration and calculates the magnitude of the ion currents. The ion currents are then averaged as needed, offset corrected and transmitted to the host computer over RS232 for immediate display.

Several built-in checks constantly monitor the operation of the probe and its operating environment. For example, the filament emission, and the electron multiplier, are immediately turned off in the case of accidental overpressure.

RS232/DCE/28.8k Connector

Use this connector to interface the RGA to a computer. The RS232 interface connector of the RGA is configured as a DCE (transmit on pin 3, receive on pin 2) with full RTS/CTS handshaking enabled. Use a straight through RS232 cable with 9-pin, type D connectors to connect the computer (usually DTE) to the ECU. The communication parameters are **fixed** at: 28,800 baud rate, 8 databits, no parity, 2 stop bits.

Calibration Lockout

A calibration disable jumper (JP100) can be configured to block any attempt to change the value of the mass filter settings in the RGA Head. The jumper is located on the top electronics board of the ECU box, next to the microprocessor chip (i.e. biggest component on the board), and its two settings are clearly indicated as CAL DIS and CAL EN. Supervisors may use this feature to prevent accidental

changes in the calibration parameters by inexperienced operators. Peak tuning is completely disabled when the jumper is configured to the CAL DIS setting.

Electrometer

Detection limit vs. scan rate

A unique, temperature-compensated, logarithmic picoammeter built into the ECU box measures the ion currents collected by the Faraday cup (FC), or electron multiplier (CDEM). The output voltage of the electrometer is equal to the logarithm of the ion current so that several decades of signal can be read on the meter without any gain switching being necessary. The microprocessor automatically configures the electrometer and connects its input to the correct signal based on the type of detector being used.

The electrometer is completely autoranging and measures both positive and negative currents with the same accuracy and resolution. Its operating range covers current magnitudes between 1.32×10^{-7} and 10^{-15} A.

The accuracy of the measurements is insured by an internal calibration procedure that calibrates the output of the electrometer against input current over its entire operating range, and stores a calibration table in the non-volatile memory of the RGA Head. *Instead of simply relying on the intrinsic logarithmic I-V behavior of the electrometer, a digital logarithmic interpolation algorithm calculates the currents from the calibration curve.*

The I-V response of the electrometer can be recalibrated at any time through a single command (CL) supported by the RGA Windows software (Calibrate Detector option in the Head menu), making it possible to generate accurate readings under different operating conditions.

Excellent resolution is achieved using a 16 bit A/D converter to digitize the output of the electrometer. The bandwidth and detection limit of the logarithmic electrometer are fully programmable. This programmability is achieved biasing the electrometer with extra current from a microprocessor-controlled current source. The biasing current is added to the ion current and sets the gain and bandwidth of the electrometer during measurements. An increase in the biasing current results in lower I-V gain and larger bandwidth, but also means increased baseline noise due to the additional shot noise introduced by the extra current. During regular mass scans the RGA automatically adjusts the scanning rate and averaging to match the bandwidth of the detector. The microprocessor calculates the total current flowing into the meter using the interpolation algorithm described above, and subtracts the biasing current from the total to provide the actual ion current values used for averaging. Obviously, the amount of biasing current must be chosen keeping in mind the strong interplay between bandwidth (i.e. acquisition rates) and baseline noise (i.e. minimum detectable partial pressures).

The single command NF (Noise Floor), supported by the RGA Windows program, is used to program the electrometer's response. Histogram scans, analog scans, single-mass measurements and total pressure measurements all share the same NF setting during measurements. A decrease in the Noise-Floor setting reduces the biasing current resulting in longer measurement times with cleaner baselines and lower detection limits. As mentioned above, the NF parameter value must be chosen keeping in mind the compromise between detection limit and acquisition speed.

When using the RGA Windows program to operate the RGA, the Scan Speed parameter setting available in the Scan Parameter Setups of the Scan menu is used to set the NF parameter value in the RGA Head according to the equation: $NF = \text{ScanSpeed} - 1$.

The following table summarizes the performance of the RGA electrometer during mass measurements as a function of the Scan Speed and NF settings. Please refer to this table to estimate minimum detectable partial pressures and scan rates for different scanning conditions.

Scan Speed parameter	NF parameter	Scan rate (msec/amu)	Single mass meas. time (msec)	Baseline noise ^(a) (std.dev.)(Amps)
1	0	2000	2200	7e-15
2	1	1000	1100	1e-14
3	2	400	440	1.5e-14
4	3	200	220	2e-14
5	4	126	139	4e-14
6	5	45	50	1.2e-13
7	6	30	33	2.5e-13
8	7	15	16.5	5e-13

(a) The values in this column are the result of averaging a large number of data points from several different units. Use this values *for reference only*. Variations are to be expected from unit-to-unit, as a function of operating conditions and even as a function of time.

Adjusting the Zero of the Ion Detector

The zero of the ion detector is automatically readjusted at the beginning of each analog and histogram scan so that the baseline is always centered around zero. The zero can also be readjusted at any time with the command CA. In both zeroing procedures, the output of the electrometer is measured in the absence of input ion current and stored, as a current value, in the RGA's memory. The current value (called offset correction factor) is then automatically used by the firmware to offset-correct all ion currents measured (i.e. including those from single mass and total pressure measurements) under the same detector settings. The detector settings are the electrometer's noise floor parameter value and the type of detector (i.e. FC or CDEM) in use at the time the zeroing is performed. Offset correction factors for all the possible combinations of detector settings can be generated and accumulated in the RGA's memory. However, all offset correction factors are cleared after a recalibration (CL) of the electrometer is performed, and when the unit is turned off.

Please consult the RGA Command Set section for details on the CL and CA commands.

Mass Filter Power Supply

All the necessary electronics required to power up the quadrupole mass filter during mass measurements are built into the ECU box. The RF/DC levels for each mass are set and regulated from the ECU, under microprocessor control, and based on internal calibration parameters permanently stored in non-volatile memory.

The difference between the three spectrometer models (100, 200 and 300) is given by the maximum supply voltage available to the rods. For example, the maximum RF amplitude delivered to the probe in the RGA300 is 1284 V (2568 Vpp) and corresponds to ions with mass of 300 amu (8.56Vpp/amu). The corresponding DC potential is a maximum of about 430 VDC for masses of 300 amu (+215 Vdc on one rod pair, and -215 Vdc on the other).

The frequency of operation of the mass filter is the same for all models and is fixed at 2.7648 MHz by an internal clock.

The rod structures in the mass filter are primarily capacitive, so to reduce the circuit drive requirements, the rod reactance is resonated with an inductance. The advantages of this resonant drive circuit is the primary reason for operation at a fixed frequency.

The internal calibration parameters used by the microprocessor to set the RF/DC levels during scans and measurements, are pre-programmed at the factory as part of the test and calibration procedures performed on the instrument before shipping. However, the parameters can be readjusted easily and whenever necessary using the Peak Tuning procedures described in the User's Manual.

Ionizer

Positive ions are produced in the ionizer by bombarding gas molecules with electrons derived from a heated filament. The ions are then directed toward the entrance of the ion filter where they are separated based on their mass-to-charge ratio.

Description

The SRS RGA ionizer is of an open design (wire mesh construction) with cylindrical symmetry and mounted co-axially with the filter assembly. The open configuration provides unrestricted communication between the vacuum environment and the ionizing region. The entire assembly is built out of type 304 stainless steel for complete vacuum compatibility. The simple mesh design is very clean (low outgassing) and easy to service.

The principle parts of the ionizer are: the repeller, the anode grid, the filament and the focus plate.

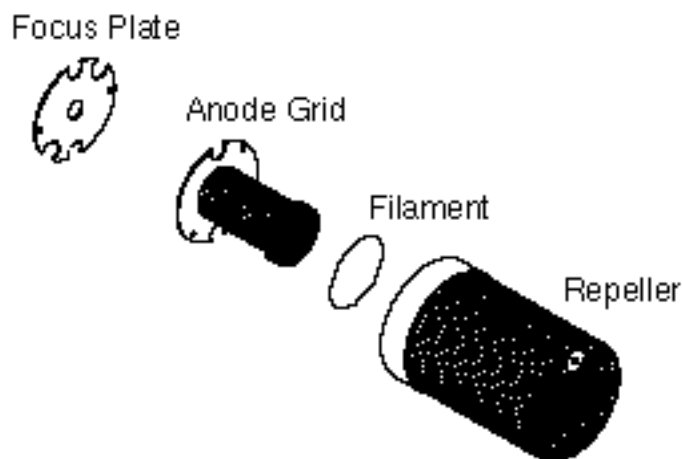

Figure 3 Ionizer Components

The filament is made out of oxidation-resistant thoria coated iridium wire, which operates at low temperature and can be exposed to atmosphere without the risk of burn-out. The circular construction consisting of two ThO_2/Ir wires surrounding the anode grid preserves the cylindrical symmetry of the ionizer. Both filaments operate simultaneously under normal operation, and service is not interrupted if a single filament burns out (i.e. the emission regulator automatically readjusts the temperature of the remaining filament to restore the electron emission current). Once they wear out, the filaments can easily be replaced in the field (Please see the Service chapter for details). A firmware driven filament-protection feature constantly monitors (675 Hz) for overpressure. If overpressure is detected the filament is immediately shut off, preserving its life.

Principle of operation

The principle of operation of the ionizer is similar to the Bayard-Alpert gauge, except there is no central wire collector, and the electron repeller has been added.

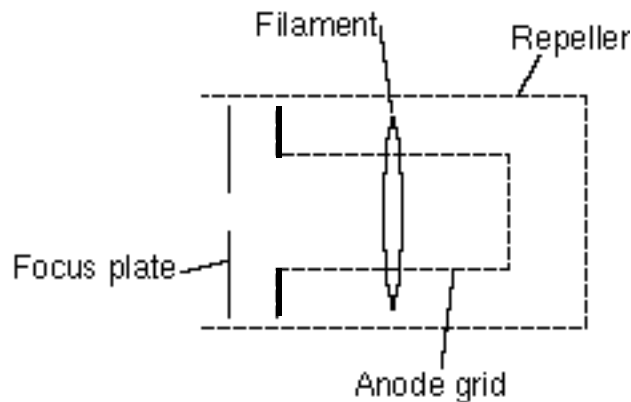

Figure 4 Ionizer Schematic

The filament is the source of the electrons used in ionizing the gas molecules. It operates at a negative potential relative to ground and is resistively heated to incandescence with an electrical current from the emission regulator. The thermionically emitted electrons are accelerated towards the anode grid which is positively charged with reference to the filament and ground. Because of the open (i.e. wire mesh) design of the anode grid cage, most electrons do not strike the anode immediately, but pass through the cage where they create ions through electron impact ionization. Electrons which do not strike a grid wire or ionize any molecules, pass through the grid volume into the region between the anode grid and the repeller. There they decelerate and re-accelerate back toward the grid because of the electric field created between the repeller and the anode grid. Electrons continue circulating in this fashion until they are collected by the grid or are lost by recapture. The multiple passes increase the ionization efficiency of the electron current relative to single pass configurations. Within the anode grid volume, ions are attracted to the center by the negative potential produced by an increasing electron density toward the center. Hence, the ions, once formed, tend to stay within the anode grid structure, and the ion distribution is more localized along the axis. The ions formed within the anode grid volume, are extracted from the ionizer by the electric field produced by the difference in voltage bias between the anode grid and the focus plate. The focus plate is kept at a negative potential (relative to ground) and its function is to draw the ions out of the anode cage and focus them into the filter section. The repeller, which completely encloses the ionizer, is biased negative relative to the filament and prevents the loss of electrons from the ion source. **The Repeller Grid and the Focus Plate are only biased while the filament is emitting electrons.**

The technique of electron impact ionization requires low pressure for the efficient production of electrons and the subsequent formation of ions. The ionizer is best suited for operation in the high and ultrahigh vacuum range (10^{-4} to 10^{-14} Torr). Non-linearities in the ion currents, attributed mostly to space charge effects, are to be expected at pressures above 10^{-5} Torr. Non-linearity effects can be minimized operating at reduced electron emission current settings.

Parameter Settings

The parameters that affect the ionization efficiency of the ionizer are: electron energy, ion energy, electron emission current and focusing voltage. The general principles by which they affect the performance of the source are well understood.

The ECU contains all the necessary high voltage and current supplies needed to bias the ionizer's electrodes and establish an electron emission current. The ionizer settings can be directly controlled and monitored by the user through the RGA's high level command set.

The following table summarizes the ionizer settings available to the user, including default factory values, parameter ranges and minimum acceptable increments:

Ionizer settings:

	Units	Default	Range	Min. Incr.
Ion Energy	eV	12	8(low) or 12(high)	n.a.
Electron Energy	eV	70	25 to 105	1
Focus Voltage	V	-90	0 to -150	1
Emission Current	mA	1.00	0 to 3.5 mA	.02

The average **electron energy**, expressed in eV, is equal to the voltage difference between the filament and the anode grid and can be set anywhere in the range of 25 to 105 eV. For electrons to produce ionization of gas molecules by bombardment, they must have a certain minimum kinetic energy. This minimum energy is called the **ionization potential** and is different for every molecule. Above the threshold, the ionization efficiency increases linearly with the electron energy until a maximum is reached. For most molecules, this maximum is in the range of about 50 -100 eV, and for electron energies above the maximum, the ionization efficiency slowly decreases with electron energy.

The kinetic energy of the ions as they move down the ion filter, simply referred to as the **ion energy**, and expressed in eV, is equal to the voltage biasing of the anode grid. Two ion energy settings (i.e. anode grid voltages) are: 8 (low) or 12 eV (high). The ion energy setting affects the magnitude of the ion signals collected (i.e. sensitivity of the spectrometer) and limits the ultimate resolution of the mass filter. Newly formed ions are attracted by the negative potential of the focus plate and passed to the ion filter where they are decelerated by the ground potential at the central axis of the quadrupole rod assembly. Hence, the anode grid voltage defines the kinetic energy of the ions as they enter the ion filter. Ion energy determines the time spent by the ions in the filter and hence, limits the resolution that can be obtained. It is well established that the resolution limit is governed by the number of cycles of RF field to which the ions are exposed before they reach the detector. In practice, the minimum resolution, $\Delta m_{10\%}$, is mass independent, linearly related to the ion energy, and inversely proportional to the square of the product of the quadrupole length and frequency. The two available ion energy settings correspond to ultimate resolutions of approximately 0.3 and 0.5 amu (well under the 1 amu factory default setting).

Ion energy also determines the time spent by the ions in the fringing fields at the entrance and exit points of the filter. Ions passing through the fringing fields can collect high transverse velocities and are more likely to collide with the quadrupole rods and never be collected at the detector. As a result, ion signals (i.e. sensitivity) generally increase with ion energy.

The **focus plate** negative potential can be adjusted to any value within the range of 0 to -150 V. In general, the voltage is selected so as to optimize the ion signals. The plate serves the double purpose of drawing the ions away from the anode grid, and containing the ionizing electrons inside the source. Electron leakage into the filter is only detectable at low mass settings (1 to 10 amu) and can easily be eliminated biasing the focus plate at least 30V more negative than the repeller.

The **electron emission current** is the electron current from the filament to the grid. The available emission current range is 0 to 3.5 mA.

When an electron emission current is requested, the RGA biases the ionizer's electrodes and activates the filament's heater until the desired emission current is achieved. A "**Background Filament Protection**" Mode is automatically enabled to monitor the performance of the filament while it is emitting electrons. The Filament LED remains on as long as the filament is emitting electrons. If a problem is detected in the operation of the filament (i.e. burnt filament or overpressure), the heater is immediately shut down and the problem is reported by the LED's. If a current of 0 mA is requested, the filament's heater is shut down, the repeller and focus plate are biased to ground, the CDEM is turned off (if necessary), and the Filament LED is turned off to indicate the absence of emission in the ionizer.

The electron emission current is very tightly regulated by a feedback control loop which dynamically adjusts the operating temperature of the filaments to keep the total emission current constant. The emission of electrons from the filaments is limited by space-charge effects (Child's Law limitations). The maximum current attainable is a function of the grid-to-repeller spacing and its potentials. Ideally, the rate of formation of ions should be proportional to the electron emission current. In practice, the exact dependence between ion signal and electron emission current in small ion sources is complicated by space-charge effects and only general trends can be predicted. Greater ionization efficiency is to be expected as the electron emission current increases.

Quadrupole mass filter

Positive ions are transferred from the ionizer into the quadrupole where they are filtered according to their mass-to-charge ratios. Ions that successfully pass through the quadrupole are focused towards the detector by an exit aperture held at ground potential.

Description

The quadrupole mass filter is an electrodynamic quadrupole operated by a combination of DC and RF voltages. It is constructed of four electrically-conducting, cylindrical rods accurately held in place by a set of two high-purity alumina insulators.

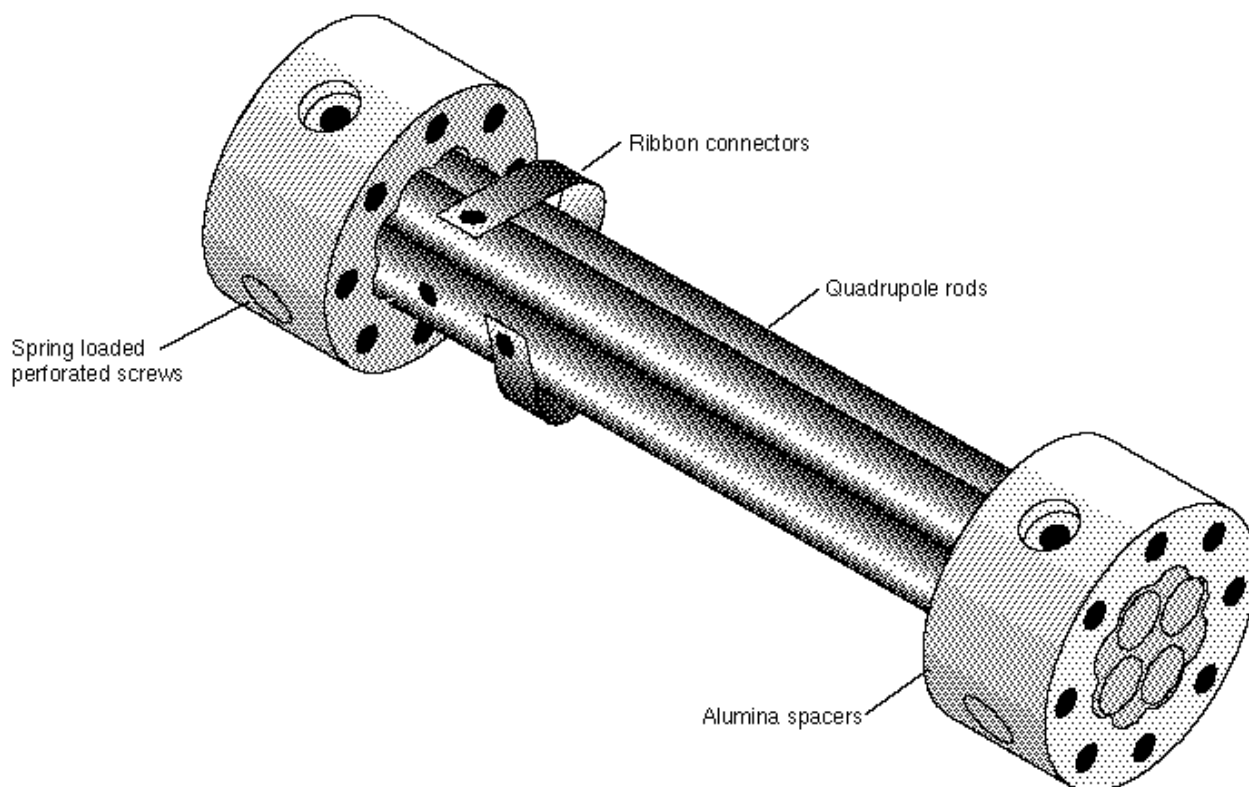

Figure 5 Quadrupole Mass Filter Components

In modern RGA's, round electrodes are a common replacement for hyperbolic ones and result in reduced cost and ease of construction. The stainless steel (type 304) rods are 4.5" long, have a 0.250" diameter (100 μ m tolerance) and are held in quadrature and parallel to each other, to tolerances better than 300 μ m, by the precision ground alumina spacers. Spring loaded, perforated screws fasten the rods to the spacers. The whole assembly is self-aligning, can easily be taken apart for cleaning and it can withstand repeated cycling to 350°C for bakeout. The exact placement of the rods is optimized to minimize the distortion of the electrodynamic quadrupole field by canceling higher order (multipole)

potential terms. The radius of the circle inscribed by the rods is 0.109". The frequency of operation is $f=2.7648$ MHz.

Principle of operation

The following figure schematically represents the quadrupole mass filter and its connections.

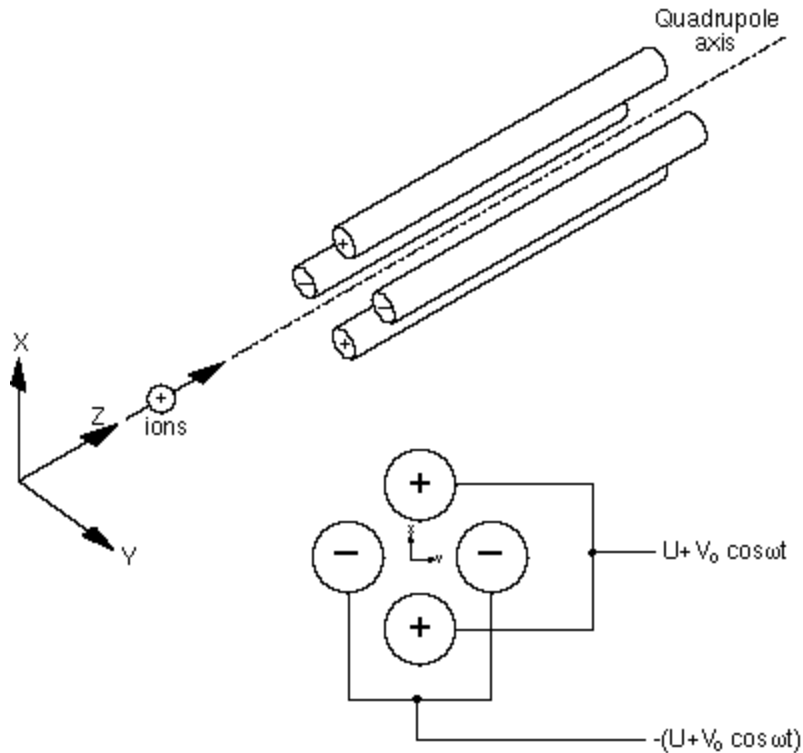

Figure 6 Quadrupole Connections

During operation, a two dimensional (X-Y) quadrupole field is established between the four cylindrical electrodes with the two opposite rods connected together electrically. Ions enter the filter along the Z-axis and start oscillating in the X- and Y- directions. The ions are separated based on their mass-to-charge ratio by lateral forces resulting from the electric potentials applied to the rods. A combination of DC and RF voltages control the quadrupole filter operation. Successful separation of a specific mass species requires setting the RF and DC values such that only the ions of interest have stable trajectories down the quadrupole rod assembly. By simultaneously varying the amplitude of the DC and RF voltages an entire mass spectrum can be scanned.

The RGA is completely calibrated at the factory so that the ECU automatically programs the RF and DC voltages on the rods to the necessary levels during scans or individual mass measurements. The calibration parameters can be accessed and modified by the user in case recalibration or a change in resolution is required. (Please see the RGA Tuning chapter for details.)

The quadrupole mass filter must be operated in a vacuum. Linear operation can be expected up to pressures of the order of 10^{-4} Torr. In general quadrupoles can be operated at relatively high pressures

compared to other types of analyzers. The upper limit of useful operation is determined by the collisions between the ions and the neutral gas molecules. In order to avoid collisional scattering it is necessary to maximize the mean free path of the ions.

The general principle of operation of the filter can be visualized **qualitatively** in the following terms: One rod pair (X-Z plane) is connected to a positive DC voltage upon which a sinusoidal RF voltage is superimposed. The other rod pair (Y-Z plane) is connected to a negative DC voltage upon which a sinusoidal RF voltage is superimposed, 180 degrees out of phase with the RF voltage of the first set of rods. The potentials are represented by the expression:

$$V_{x/y} = \pm (U + V_0 \cos \omega t)$$

where,

U is the magnitude of the DC voltage applied to either pair of rods,

V_0 is the amplitude of the RF voltage applied to either set of rods, and

ω is the angular frequency ($=2\pi f$) of the RF.

Light ions (low mass-to-charge ratio) are able to follow the alternating component of the field. For the **X direction**, those ions will stay in phase with the RF drive, gain energy from the field and oscillate with increasingly large amplitudes until they encounter one of the rods and are discharged. Therefore, the X direction is a **high-pass mass filter**: Only high masses will be transmitted to the other end of the quadrupole without striking the X electrodes. On the other hand, in the **Y direction**, heavy ions will be unstable because of the defocusing effect of the DC component, but some lighter ions will be stabilized by the alternating component if its magnitude and amplitude are such as to correct the trajectory whenever its amplitude tends to increase. Thus, the Y direction is a **low-pass mass filter**: Only low masses will be transmitted to the other end of the quadrupole without striking the Y electrodes.

The two directions together give a **mass filter suitable for mass analysis**: By a suitable choice of RF/DC ratio the filter can be made to discriminate against both high and low mass ions to the desired degree.

The RF voltage magnitude and frequency determine the mass of the ions that undergo stable trajectories down the filter. As the RF amplitude increases, heavier ions start to oscillate in phase with the RF and collide with the rods. The DC/RF ratio determines the filter selectivity. As the DC increases (at constant RF) heavier ions are defocused by the negative DC component.

The attractive features of the quadrupole as a mass analyzer are evident from the above discussion: **The quadrupole provides a convenient filter which can be tuned to the desired mass by varying the amplitude of the RF voltage; the mass selectivity (i.e. resolution) can also be varied electronically by simply adjusting the DC/RF ratio.** Simultaneously varying the amplitude of the DC and RF voltages allows entire mass spectra to be scanned.

Mass Range, Resolution and Throughput

The most important characteristics of a quadrupole are the **mass range**, its **ultimate resolution** and its **throughput** characteristics.

The **mass range** is the range of masses defined by the lightest and the heaviest singly charged ions which can be detected by the mass spectrometer. The spectrometer is offered in three different models with mass ranges of 1 to 100, 200, and 300 amu. The main difference between the three models is given by the maximum supply voltage available to the rods.

The terms **Resolution** and **Resolving Power** are often used by mass spectroscopists to express the ability of a mass filter to **resolve** ions having different masses:

Resolution, or Absolute Resolution = $DM_{10\%}$: The width DM of the pass band of the filter, defined as the full width at which the ion current falls down to 10% of the maximum value. Units = amu.

Resolving Power: $R = M/DM_{10\%}$: Ratio between a particular mass M and the resolution, $DM_{10\%}$, at that mass. Dimensionless ratio.

It is common practice in modern RGA's to keep $\Delta M_{10\%}$ constant at a value which insures adequate separation of masses that are 1 amu apart. The SRS RGA quadrupole operates in that "Constant Resolution" or "Constant Δm " mode. $\Delta M_{10\%}$ is preset at the factory to 1 amu, but it can easily be adjusted by the user all the way to the theoretical ultimate resolution of the filter.

The following figure illustrates the resolution concepts explained above, using a Krypton mass spectrum as an example. The different isotopes of the gas are well separated from each other, and a 1 amu peak width ($=\Delta m_{10\%}$) is measured on the ^{86}Kr peak at 10% of its peak height. Also notice the 20% valley between the ^{82}Kr and ^{83}Kr peaks.

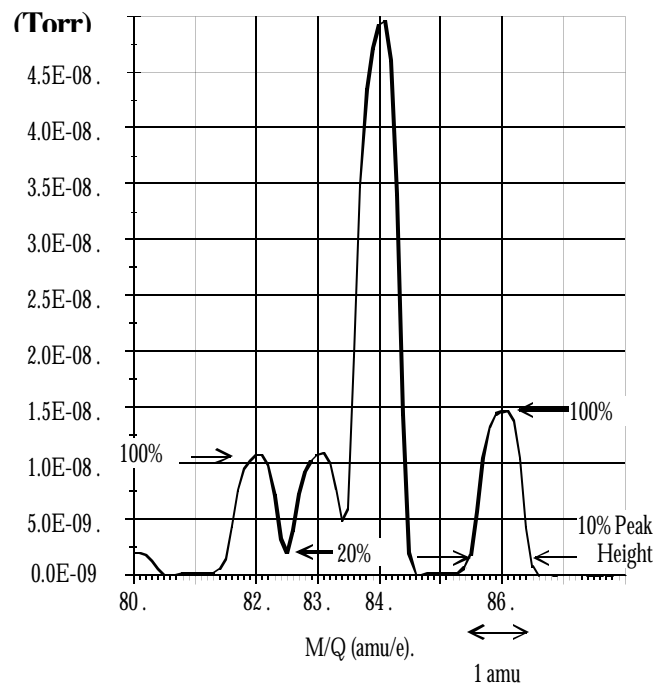

Figure 7 Peak Width Measurement

It is well established that the resolution attainable by a quadrupole is limited by the number of cycles of RF field to which the ions are exposed before they reach the detector. In practice, the minimum resolution ($\Delta M_{10\%}$) value attainable is mass independent, linearly related to the ion energy, and inversely proportional to the square of the product of the quadrupole length and frequency. The two available ion energy settings of the RGA correspond to **ultimate resolution** values of approximately 0.3amu (8 eV) and 0.5 amu (12eV) which are well under the factory default setting, and more than adequate to separate ions which differ in mass by 1 amu or less.

The resolving power, R, at a mass M is strictly related to the DC/RF voltage ratio. An increase in the resolving power usually results in a decrease in the effective **throughput** of the filter. As the DC/RF ratio is increased the amplitude of the ion oscillations within the filter increase and a greater fraction of the ions are lost to collisions with the analyzer rods. The throughput of the quadrupole affects the overall **sensitivity** of the spectrometer to the mass being filtered. The exact relationship between resolution and sensitivity is very complex as it depends on the concentration and divergence of the ion beam leaving the source. It is complicated further by the defocusing action of the fringing fields between the ion source and the rods. However, as a general rule of thumb **Sensitivity decreases at 1 to 1.5 times the rate of resolving power increase.**

The inverse relationship between sensitivity and resolving power is also responsible for a very important feature of quadrupole mass filters operated at constant resolution: **The throughput of the analyzer decreases with mass.** (Since $\Delta M_{10\%}$ is constant, the resolving power, $R = M / \Delta M_{10\%}$, increases with mass reducing the effective throughput of the filter for high masses. This effect must be taken into account when calculating partial pressure sensitivities from ion currents.)

Zero Blast Suppression

When the applied potentials are small (or zero) as at the beginning of a scan, ions entering the filter may be transmitted even though their trajectories are mathematically unstable, just because of the weakness of the fields and the finite length of the filter. This gives rise to an output signal at the beginning of mass scans called the "Zero Blast". In the SRS RGA the Zero Blast is suppressed preventing the DC voltage from reaching zero under 1.5 amu.

Ion Detector

Positive ions that successfully pass through the quadrupole are focused towards the detector by an exit aperture held at ground potential. The detector measures the ion currents directly (Faraday Cup) or, using an optional electron multiplier detector, measures an electron current proportional to the ion current.

Description

The following figure describes the detector assembly including the electron multiplier option.

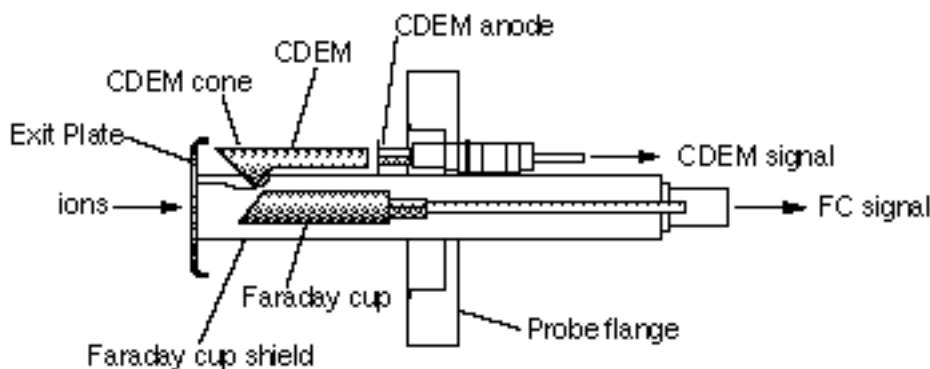

Figure 8 Detector Components

The **Faraday Cup (FC)** is a small stainless steel (type 304) metal bucket located on-axis at the end of the quadrupole. It is shielded from the intense RF and DC fields of the quadrupole by the grounded **exit plate**, which also provides some focusing of the ions into the detector. A cylindrical tube (**FC Shield**) encloses the FC, protecting it from the strong electrodynamic potentials of the adjacent rods and from collecting ions originated at sources other than the ionizer. The signal is carried to the electrometer through a coaxial feedthru which extends into the ECU box and efficiently shields the small ion currents. The FC is attached to the center feedthru with a push-on connector and can easily be pulled out for cleaning or modification.

Notice that an electron suppressor electrode (commonly found in several commercially available RGA's) is not part of this detection setup since the large aspect ratio (length-to-diameter) of the FC assures efficient recapture of secondary electrons.

The **electron multiplier** is a state-of-the-art **Macro Multi-Channel Continuous Dynode Electron Multiplier (CDEM)**. It consists of a straight, four-channel tube made out of a special resistive glass (i.e. high secondary electron emission yield) with a cone of the same material attached to the front end. It is placed upright, next to the FC, and away from the axis of the analyzer (**off-axis configuration**). It is held safely in position by a clamp and a clip. The clamp is connected to the neighboring rod that carries the voltage from the High Voltage power supply, and is responsible for biasing the cone as well as assuring its correct placement next to the FC. A hole on the side of the FC Shield allows space for

mounting the CDEM cone very close to the top of the FC. The clip anchors the CDEM glass tube to the side of the FC Shield and holds the lower end of the tube at ground. Chrome electrical coatings, deposited at both ends of the tube provide the necessary electrical contacts. A plate (CDEM Anode) mounted at the exit of the CDEM collects the secondary electrons. The resulting electron current flows into the electrometer through a separate feedthru of the flange.

The entire setup is **self-aligning** and easily serviced by the user in the field. For example, removing the screw that fastens the clamp to the HV rod is all that is needed to replace the CDEM (Please see the Maintenance chapter for details.)

Faraday Cup operation

The Faraday Cup (FC) detector, measures the incident ion current directly. Positive ions enter the grounded detector, strike a metal wall, and are neutralized by electron transfer from the metal to the ion. The electrons given up in this process establish an electrical current that has the same intensity as the incoming ion current.

Since the nominal sensitivity of the RGA is in the order of 10^{-4} Amps/Torr, the currents measured are very small: 10^{-9} to 10^{-15} Amps for pressures in the order of 10^{-5} to 10^{-11} Torr, respectively. Minimum-detectable-partial pressures as low as $5 \cdot 10^{-11}$ Torr are possible with the FC. However, in real-time applications, FC detectors are rarely used to measure partial pressures below 10^{-9} Torr. At pressures below that value, the CDEM option becomes a much better alternative allowing for faster scan rates and improved signal-to-noise ratios.

The best characteristics of FC detection are: simplicity, stability, large dynamic range and lack of mass discrimination. **All ions are detected with the same efficiency regardless of their mass.**

The ECU automatically connects the FC electrode to the electrometer input upon power-on reset, and whenever the electron multiplier is not turned on.

Electron Multiplier Operation

Macro Multi-Channel Continuous Dynode Electron Multipliers are used in the SRS RGA. They consist of a straight four-channel tube made out of a special resistive glass (i.e. high secondary electron emission yield) with a cone of the same material attached to the front end. The extruded channels run along the length of the device and are twisted at the time the part is drawn to eliminate ion feedback. Each CDEM is placed upright next to the FC and away from the line of sight of the ionizer (i.e. off-axis configuration). When the cone is biased negatively (-1000 to -2500V) relative to the back end, positive ions are very efficiently attracted away from the FC and strike the cone at high velocity producing electrons by secondary electron emission. The secondary electrons are subsequently accelerated down the four channels and produce more secondary electrons. For each ion entering the cone of the CDEM, and depending on the bias voltage applied, up to 10^7 electrons come out at the back end and are picked up by a grounded plate (the CDEM anode). The resulting electron current is proportional to the ion current and is measured by the same logarithmic electrometer used in the FC measurements. The sign

of the electron multiplier currents is reversed before the current value is sent out over RS232 so that the computer does not need to do any sign flipping on the currents received when the CDEM is activated.

The gain of the electron multiplier in the RGA is a function of the bias voltage and is measured relative to the FC signal. The following figure shows a typical “**gain characteristic**” (i.e. gain vs bias voltage) curve obtained for H_2O^+ ions at 18 amu.

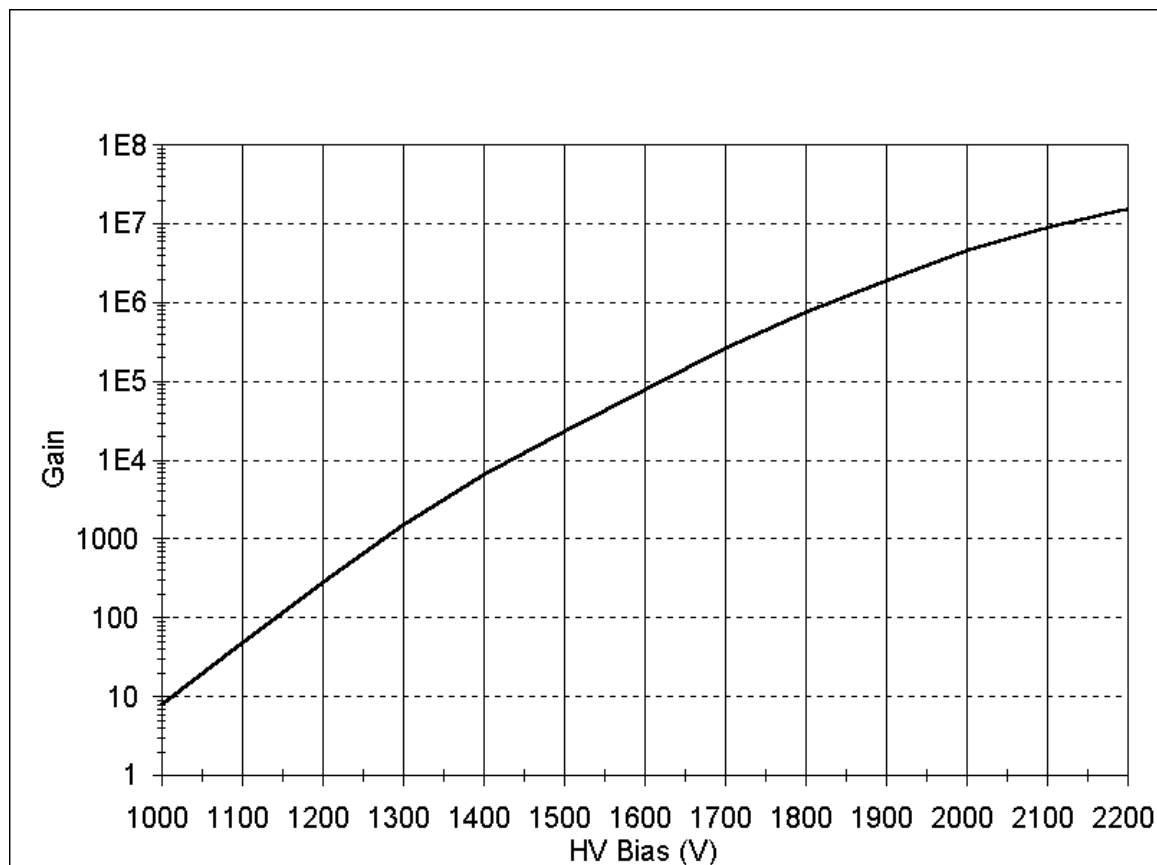

Figure 9 Typical CDEM Gain Characteristic Curve

Very high gain values can be obtained and controlled with voltages smaller than -2500 Volts. **The sensitivity of the spectrometer increases with the gain of the electron multiplier.** Higher sensitivities provide lower minimum detectable partial pressures and faster spectral scans. Minimum detectable partial pressure limits as low as $5 \cdot 10^{-14}$ Torr are commonly achieved.

However, the increase in sensitivity is obtained at the price of limited dynamic range, mass discrimination effects, gain instabilities and finite lifetime of the device. A good understanding of these limitations is very important to assure accurate quantitative measurements.

The **dynamic range** of electron multipliers is determined by their dark current at the low end, and by the bias current value at the high end.

The **bias current** is established by the external voltage drop along the resistive glass tube and flows

along the channel walls replenishing their charge as secondary electrons are emitted. **Channel electron multipliers, operate linearly in the analog mode until the output current is approximately 10% of the bias current.**

The **dark current** of a multiplier is the electron current measured at its output in the absence of an input ion current. **The minimum output current that can be accurately measured with the multiplier is equal to the dark current noise.**

Example: For a typical resistance of 200 M Ω , and a bias voltage of -2000V, the bias current is 10 μ Amps and the output current must be kept under 1 μ Amp. Since the gain at that voltage is roughly 10^6 , the maximum input current at which the output current behaves linearly is 10^{-12} Amps (1 μ Amp / 10^6). Typical dark currents are lower than 10^{-13} Amp, and the minimum input current that can be detected is 10^{-19} Amps. For a sensitivity of 10^{-4} Amp/Torr, this corresponds to a lower and upper limits of 10^{-15} and 10^{-8} Torr, respectively, and 7 orders of magnitude of dynamic range.

The total gain of electron multipliers varies as a function of the mass of the incident ions. As a rule of thumb, and for small molecules, **the gain decreases as mass increases**. This mass discrimination effect is caused by the dependence of ion-electron conversion efficiencies on the velocities of the ions entering the detector. For example, an inverse relationship with the square root of the mass has been reported for monoatomic ions of the same energy. For accurate quantitative measurements, it is essential to calibrate in advance the gain of the multiplier for the specific ionic species being detected.

An important problem when working with multipliers is that their gain changes with time. **Gain degradation** is unavoidable, and particularly serious just after the detector has been exposed to air, or after high quantities of reactive gases have been introduced into the vacuum system. The increased surface area provided by the extra channels in the multi-channel devices reduces this problem; however, frequent calibration of the multiplier gain against the FC output is recommended for reliable quantitative measurements. This is done automatically with the RGA Windows™ software.

Gain degradation limits the **lifetime** of all electron multipliers. Eventually the gain drops to unacceptable values and the multiplier needs to be replaced. As a rule of thumb, **the multiplier should be replaced when the required gains can no longer be achieved by increasing the bias voltage**. The lifetime of electron multipliers is ultimately dependent upon the accumulated charge drawn from the multiplier (**Gain degradation typically starts at accumulated output current values of a few thousand μ Amp-hr**). However, the lifetime also depends critically on the residual gas environment and the duration of transient signals. Contamination by organic compounds (i.e. diffusion or mechanical pump oil) and the interaction with highly reactive gases must be avoided at all times.

It has been found that, in many cases, channel multipliers may be successfully **refreshed** by cleaning them in high purity isopropyl alcohol. The procedure is described in the RGA Maintenance chapter (CDEM Refreshment section) and, even though **it is not guaranteed to always work**, it is worth trying as a last resort before discarding a multiplier.

Channel electron multipliers have a history of high performance and dependability in mass spectrometry

applications. However, in order to achieve maximum useful lifetime and optimum performance, it is very important to handle them very carefully. Please read the **CDEM Handling and Care** section in the Service chapter to familiarize yourself with some of the basic procedures that must be followed for the correct operation of the multipliers.

Chapter 3.

Programming the RGA

This chapter describes how to program the RGA ECU from a host computer using the RGA Command Set and an RS232 Link.

In This Chapter

Introduction	3-3
The RGA COM Utility	3-4
Command Syntax.....	3-5
Examples of command formats.....	3-5
Programming tips	3-6
Communication Errors	3-7
Command errors	3-7
Parameter errors	3-7
Jumper Protection Violation.....	3-8
Troubleshooting the RGA communications.....	3-8
Programming the RGA ECU.....	3-9
Initializing the RGA ECU	3-9
Programming the Ionizer.....	3-10
Programming the Detector.....	3-11
Setting up Analog Scans.....	3-13
Setting up Histogram Scans.....	3-14
Single Mass Measurements.....	3-16
Total Pressure Measurements	3-18
Storing Information in the RGA ECU.....	3-19
Programming the Quadrupole Mass Filter.....	3-20
Error Checking the RGA	3-21
RGA Command Set.....	3-25
Initialization Commands.....	3-26
ID?	3-26
IN0, IN1, IN2.....	3-26
DGparam, param: 0 - 20,*	3-28
EEparam, param: 25 - 105, *, ?.....	3-29
FLparam, param: 0.00 - 3.50, *, ?.....	3-30
IEparam, param: 0,1, *, ?	3-31
VFparam, param: 0 - 150, *, ?.....	3-32
Detection Control Commands.....	3-34
CA.....	3-34
CL.....	3-35
HVparam, param: 0 - 2490, *, ?.....	3-36
MO?.....	3-38
NFparam, param: 0 - 7, *, ?	3-38
Scan and Measurement Commands.....	3-40
AP?	3-40
HP?	3-40
HSparam, param:0 - 255,*	3-41
MFparam, param: 1 - M_MAX, *, ?.....	3-43

MIparam, param: 1 - M_MAX, *, ?	3-44
MRparam, param:0 - M_MAX.....	3-44
SAParam, param: 10 - 25, *, ?.....	3-46
SC[param], param: 0 - 255, *	3-47
TP?, TP0, TP1	3-49
Parameter Storage Commands.....	3-51
MGparam, param: 0.0000 - 2000.0000,?.....	3-51
MVparam, param: 0 - 2490,?.....	3-51
SPparam, param:0.0000 - 10.0000, ?.....	3-52
STparam, param:0.0000 - 100.0000, ?.....	3-53
Mass Filter Control Commands.....	3-54
MLparam, param: 0.0000 - M_MAX.....	3-54
Error Reporting Commands.....	3-55
EC?	3-55
ED?	3-55
EF?.....	3-56
EM?	3-56
EP?.....	3-57
EQ?.....	3-57
ER?	3-58
Tuning Commands.....	3-60
CE?	3-60
DIparam, param: 0 - 255, *, ?.....	3-60
DSparam, param: -0.8500 - +0.8500, *, ?	3-61
RIparam, param: -86.0000 - +86.0000, *, ?, none.....	3-63
Error Byte Definitions.....	3-66

Introduction

The RGA comes standard with an RS232 communications port. A host computer interfaced to the RGA can easily configure, calibrate, diagnose and operate the quadrupole mass spectrometer using ASCII commands. The RGA ECU executes the commands in the order received and, when information is requested, data is quickly returned to the computer for analysis and display.

The fast exchange of data between the host computer and the RGA provides dynamic information about the status of a vacuum process or system. This Command Set facilitates integration of all the RGA functions into any processing or diagnostic program.

The RS232 interface connector of the RGA is a standard 9 pin, type D, female connector configured as a DCE (transmit on pin 3, receive on pin 2) with full RTS/CTS handshaking enabled. The CTS signal (pin 8) is an output indicating that the RGA is ready, while the RTS signal (pin 7) is an input that is used by the host computer to control the RGA's data transmission.

The communication parameters are fixed at: 28,800 baud rate, 8 databits, no parity, 2 stop bits.

Cable connection: Use a straight through RS232 cable with 9-pin, type D connectors to connect the computer (usually DTE) to the ECU. The DB9 to DB25 adapter (provided with the unit) will be needed if the computer has a 25 pin Type D connector.

Important: If you use your own RS232 cable check the connectors to make sure all the necessary handshaking lines are connected correctly.

The RGA COM Utility

The RGA Com Utility is a simple Windows™ OS communication program that allows you to communicate with the RGA ECU directly by typing valid RGA commands on your keyboard. The program functions like any common terminal program where the typed characters are sent directly to the serial communications port and any received characters are displayed immediately on the screen.

The RS-232 communication parameters of RGA Com are fixed to be compatible with the RGA ECU. The only variable that may be selected is the communications port. A list of up to nine com ports is available to connect to the RGA ECU.

RGA Com Fixed parameters:

- 28.8k Baud rate
- 8 Data bits
- No Parity
- 2 Stop Bits

To connect to an RGA ECU do the following:

1. Start the RGA Com program.
2. Select the “Select Com Port...” command from the “COM port Setup” menu.
3. Select the Com port you want (usually COM2) from the list box and press OK.
4. Select the “Connect” command from the “COM port Setup” menu.
5. Begin typing commands, press “Enter” after each command to validate it.
6. When you are done select the “Disconnect” command and exit the program

Tip

- When you first connect to the ECU (step 5 above), send the ID? command to verify the connection with the RGA ECU. This command will return the model number, serial number, and firmware version of the RGA unit you are connected to.

Important

- If you make typing error the RGA’s Error LED will blink. Press “Enter” and retype the command, the Backspace character is not processed.
- When you are done using RGA Com you must disconnect the COM port or exit the program, otherwise no other Windows program can communicate with the open COM port.

Command Syntax

The RGA commands are ASCII character strings consisting of a two letter (case insensitive) **command name**, a **parameter**, and a **carriage return** terminator.

Note: The carriage return character, decimal ASCII value=13, is represented throughout this manual with the symbol <CR>. All command strings must be terminated with this character in order to be acknowledged by the RGA.

Valid **parameters** are:

Numbers: Numbers are the most common type of parameter used to program the RGA. Number parameters must be within a command-specific range and must not conflict with any pre-existing parameter values of the ECU. Only Decimal format is accepted. The fractional parts are truncated to four decimal places before being stored in memory. The '+' sign is optional for positive numbers. A zero in front of the period is optional in fractional numbers with magnitude less than one.

Asterisk “*” (default): A single asterisk indicates that the default parameter value (stored in the RGA ECU’s permanent memory) is to be used for command execution. The asterisk must be strictly followed by a <CR>.

Question mark “?” (Query): Query commands are used to read error bytes, to measure total pressure and to confirm internal parameter values. The question mark must be strictly followed by a <CR> terminator. With a few exceptions, the data returned by most query commands is a string of ASCII characters terminated by a linefeed (<LF>, decimal ASCII value=10) and a <CR> terminator: string<LF><CR>.

No parameter: Some commands do not require a parameter.

The RGA assumes a *potential* command-string has been received over RS232 when a <CR> character is detected in the serial interface. A command handler immediately analyzes the string, and if everything checks, the command is executed. However, if a problem is encountered a communication error is reported and no command execution takes place.

The RGA has a 140 character input buffer and processes commands in the order received. If the buffer fills up, the RGA will hold off handshaking on the RS232 interface using the CTS line. Similarly, the RGA has a 32,000 character output buffer to store outputs until the host computer is ready to receive. If either buffer overflows, the buffer is cleared and the error is reported. Linefeed characters (<LF>, decimal ASCII value=10) and single carriage returns (<CR>, decimal ASCII value=13) are ignored by the serial interface.

Examples of command formats

The following list of commands activates the ionizer and triggers a single analog scan from 1 to 100 amu at the default scan rate setting. Note that each one of the command character strings must be strictly followed by a <CR> character in order to be detected by the RGA’s command handler.

ID?	RGA Identification Query.
MI1	Set initial scan mass to 1 amu.
MF100	Set final scan mass to 100 amu.
FL1.0	Turn on the filament to a 1.0 mA emission current.
NF*	Use default noise floor setting. (sets scan rate and averaging.)
AP?	Query the number of scan points to be received by the computer.
SC1	Trigger a single analog scan.

Programming tips

- Whenever possible, immediately follow a command that **sets** a parameter value with one that **queries** the parameter setting in the RGA memory. For example, the second command in the list above should be followed by a MI?, and a number 1 should be echoed by the RGA.
- Whenever practical, check for errors at the end of command execution to make sure “everything went well”.
- Even though the RGA ECU can store multiple commands in its receive buffer, it is highly recommended that the host computer wait for the response of a query before a new command (especially a new query) is transmitted to the RGA. This simplifies the communications and also eliminates buffer overwrites.
- Commands that involve hardware control (such as turning the filament or the CDEM on) trigger diagnostic checks on the hardware as they are executed. Since the command execution time can be rather long, the RGA prompts the end of execution by sending back the value of the STATUS byte to the computer. Always check the value of the STATUS Byte returned for possible errors. In cases where a hardware error is reported retry the command one more time before declaring a hardware problem.
- With the exception of the ion current values, the output of the RGA are ASCII character strings terminated by a <LF><CR> terminator. Ion signals are represented as integers in units of 10^{-16} Amps, and transmitted directly in hex format (four byte integers, 2’s complement format, Least Significant Byte first) for maximum data throughput.

Communication Errors

Communication errors are signaled to the user flashing the Error LED a few times, setting Bit 0 of the STATUS error byte and setting the error-specific bits of the RS232_ERR error byte .

Many different circumstances can result in a communication error being reported after a command string is received by the RGA. Some problems are detected early by the command handler and result in the command never being executed. Other errors are found later, during the actual command execution, and they result in the execution being immediately halted.

The following is a list of the communication errors that might be encountered during the analysis and execution of a command, including the specific ways in which they are reported:

Command errors

Bad Command Name : The first two characters in a command string must be letters (case insensitive) and must be part of the Command Set, otherwise the Error LED is flashed, Bit 0 of RS232_ERR and Bit 0 of STATUS are set, and no command is executed.

Command-too-long error : 14 characters are received over RS232 without a <CR> ever being detected. The Receive buffer is flushed, Bit 2 of RS232_ERR and Bit 0 of STATUS are set, and no command is executed. *Note that the LED is not flashed for this error (only exception to the rule!).*

Parameter errors

Bad-Parameter error: Many different possibilities lead to a bad-parameter error.

- The number parameter is out of the command's acceptable range.
- A “?” is not strictly followed by <CR> in a Query command.
- A “*” is not strictly followed by <CR> in a Default command.
- A non-zero fractional part is found in a parameter that can only be an integer.
- No parameter is found in a command that strictly requires one.
- A parameter other than a “?” is found in a Query-only command.
- A default parameter value is used with a command that does not have one defined.

All Bad-Parameter errors are reported flashing the Error LED, and setting Bit 1 of RS232_ERR and Bit 0 of STATUS. No command is executed.

Parameter-conflict error: When the parameter is in conflict with some other related parameter value which pre-existed in the RGA ECU, the Error LED is flashed, Bit 6 of RS232_ERR and Bit 0 of STATUS are set and the command is not executed.

Jumper Protection Violation

Some calibration related commands are subject to jumper protection. Jumper JP100 on the digital (i.e. top) board of the RGA electronics box can be used to enable/disable some of the tuning features of the instrument. The jumper setting is checked before the command is executed and if calibration is disabled, the Error LED is flashed, Bit 5 of RS232_ERR and Bit 0 of STATUS are set, and the command is not executed. The jumper setting provides very solid protection against inadvertently tampering with important calibration parameters stored in the RGA's memory. Please refer to the "RGA Command Set" list to find out which calibration commands are jumper protected.

Troubleshooting the RGA communications

The RGA's communication interface includes a complete set of tools for troubleshooting communications between a host computer and the spectrometer's ECU during programming:

1. Visual Clue

The first clue of a communication error can be obtained watching the Error LED while communicating with the ECU.

The ERROR_LED is flashed on/off two times every time a communication error is detected.

2. Error Queries

The presence of a communication error can also be detected queering the contents of the STATUS byte in the RGA ECU. The query command **ER?** returns the value of the STATUS Byte for analysis, and a communication error is present if Bit 0 of STATUS is found set. The specific problem is determined querying the bits of RS232_ERR byte using the **EC?** which clears the RS232_ERR byte and Bit 0 of STATUS at the end of its execution to provide a clean error-reporting slate.

Communication errors accumulate in the RS232_ERR byte as they occur and the byte can only be cleared by reading it with the **EC?** command.

Note: Please refer to the "Error Byte Definitions" section of this chapter for a complete listing of the error and status bytes of the RGA. Also consult the "Error Reporting Commands" list for details on the **EC** and **ER** commands.

Programming the RGA ECU

This section describes the basic programming steps needed to configure, operate, and diagnose the RGA. The emphasis is on general program implementation without going into specific details on the different commands that are mentioned.

Please consult the “RGA Command Set” section of this chapter to get more detailed information on the RGA commands and their implementation.

Initializing the RGA ECU

The RGA ECU is ready to communicate a few seconds after it is turned on and all the built-in internal checking is performed. The Initialization commands are commonly used to test the quality of the RS232 interface, to reset the RGA’s communication buffers, to scan the hardware for problems, and to reset the unit to its default (factory preferred) parameter settings.

Initializing the RGA communications

The two commands most often used after connecting to the ECU are:

ID? Identification Query. Echoes the RGA’s ID string.

IN0 Clear communication buffers. Echoes the STATUS Byte.

The ID? command is used to test the RS232 interface: The ID String, stored in the RGA ECU, is returned to the computer and the integrity of the RS232 link is assured once the character string is received. The ID string also contains useful information such as model and serial number of the RGA ECU.

The IN0 command clears all the RGA’s RS232 buffers, runs a fresh set of tests on the ECU’s hardware and sends back the STATUS Byte. Check the value of the STATUS byte for potential errors.

Programming tips

- Use the IN0 command every time there seems to be problems with the RS232 communications. The following procedure is recommended in those cases:
 1. Reset the buffers in the computer.
 2. Send a few carriage returns to clear the RGA’s receive buffer.
 3. Send the IN0 command to reinitialize the RGA’s buffers.
 4. Wait for the STATUS error byte to come back.
 5. Test STATUS for possible errors.

This trick is very useful to reset communications on both ends and is often implemented as a menu item.

- The ID? command is used for a variety of purposes:
 - Make sure the RGA is powered up and ready to go.

- Check the quality of the serial connection to the host computer.
- Check the user's communication software to make sure it is communicating properly with the RGA.
- Check the serial numbers of the RGA ECU's connected to the computer's serial ports.

Programming the Ionizer

Positive ions are produced in the ionizer by bombarding residual gas molecules with electrons derived from a heated filament. The operational parameters that affect the efficiency of the ionizer are: electron energy, ion energy, electron emission current, and focusing voltage. The **Ionizer Control** Commands program all the ionizer voltages, turn the filament on/off, and Degas the ionizer. The STATUS byte is transmitted at the end of their execution.

Important: Remember that the repeller grid and the focus plate are only biased while the filament is emitting electrons.

Setting the ionizer parameters

The following list of commands will set the electron energy to 70 eV, ion energy to high (12eV), focus voltage to -100V and it will then turn the filament on with an emission current setting of 1.0 mA. It is a typical example of the set of commands sent to the RGA while programming the ionizer.

EE70 Electron Energy = 70 eV. Echoes the STATUS Byte.

IE1 Ion Energy = high (12eV). Echoes the STATUS Byte.

VF100 Focus Voltage= -100V. Echoes the STATUS Byte.

FL1.0 Filament emission = 1 mA and turn filament on. Echoes the STATUS Byte.

Ionizer Programming Tips

- It is possible to trigger scans and single mass measurements if the filament is not turned on.
- Make sure the pressure is under 10^{-4} Torr before turning the filament on or degassing.
- Whenever possible replace a Degas procedure with a thorough Probe Bakeout (See RGA Maintenance Chapter for details). Keep the degas time to the minimum value that will get the job done. Frequent degassing compromises the lifetime of the filament.
- The filament is frequently tested by the CPU while it is turned on. Consult the Filament, Leak and Burnt LED's after activation for immediate status feedback.
- Wait for the STATUS byte to be returned between commands and check it every time for possible errors.
- In cases were a hardware error is reported retry the command one more time before declaring a hardware problem.
- Default parameter settings are available for all the Ionizer Control commands
- Use the FL0 command to turn off the filament.

Programming the Detector

Positive ions that successfully pass through the quadrupole filter are focused towards a detector that measures the ion currents directly (Faraday Cup, FC) or, using an optional electron multiplier (CDEM), measures an ion signal proportional to the ion current.

Use the **Detection Control** commands to choose the detector type (FC or CDEM), query the CDEM option, recalibrate the electrometer's I-V response and set the electrometer's averaging and bandwidth. Use the CA command to zero the ion detector at any time.

Important: Faraday Cup detection is the default setting when the RGA ECU is turned on.

Use the MO? command to determine whether an electron multiplier option (Opt02) is available in the RGA ECU being programmed. The CDEM is available if the response is 1<LF><CR>.

The HV command activates/deactivates the CDEM detector. Its parameter value represents the bias voltage applied across the multiplier, and determines the gain of the amplifier. The null parameter, HV0, deactivates the CDEM and reconnects the FC detector to the electrometer.

Note: The ElecMult LED reflects the status of the CDEM at all times.

A temperature compensated logarithmic picoammeter measures the ion currents collected by the FC or CDEM. The microprocessor automatically configures the electrometer and connects its input to the correct signal based on the type of detector being used. The sign of the electron multiplier currents is reversed before the current value is sent out over RS232 so that the computer does not need to do any sign flipping on the currents received when the CDEM is activated. The accuracy of the ion current measurements is insured by an internal calibration procedure that calibrates the output of the electrometer against input current over its entire operating range. The I-V response can be recalibrated by the user at any time with the CL command.

The bandwidth and detection limit of the electrometer are programmed with the NF (Noise Floor) command. A decrease in the Noise-Floor setting results in longer measurement times with cleaner baselines and lower detection limits. Histogram scans, analog scans, single-mass measurements and total pressure measurements share the same NF setting. The RGA automatically adjusts the scanning rate and averaging based on the NF setting selected.

Important: The zero of the ion detector is automatically readjusted at the beginning of each analog and histogram scan so that the baseline is always centered around zero. The zero can also be readjusted at any time with the command CA. In both zeroing procedures, the output of the electrometer is measured in the absence of input ion current and stored, as a current value, in the RGA's memory. The current value (called offset correction factor) is then automatically used by the firmware to offset-correct all ion currents measured (i.e. including those from single mass and total pressure measurements) under the same detector settings. The detector settings are the electrometer's noise floor parameter value and the type of detector (i.e. FC or CDEM) in use at the time the zeroing is performed. Offset correction factors for all the possible combinations of detector settings can be generated and accumulated in the RGA's memory. However, all offset correction factors are cleared after a recalibration (CL) of the electrometer is performed, and when the unit is turned off.

Please consult the RGA Command Set section for details on the CA command.

Detector Programming example

The following list of commands starts by checking the RGA ECU to make sure there is a multiplier installed: A CDEM is present if a 1<LF><CR> response is sent back to the computer. After the test (and assuming the CDEM option was detected), a voltage of -1400V is set across the multiplier, and the noise floor setting is programmed for minimum averaging and maximum scan rate. The detector is now fully configured for CDEM measurements with -1400 V of CDEM bias voltage.

MO? Multiplier Option Query. Check query response: 1<LF><CR> confirms CDEM option.

HV1400 High Voltage CDEM = 1400V. Echoes the STATUS Byte.

NF7 Noise Floor = 7. Echoes the STATUS Byte.

Notes:

Append a CA command at the end of this list to readjust the zero of the ion detector measurements under the present detector settings. The correction factor will then be used by all measurements (i.e. single mass and total pressure) under this same detector settings to correct against zero drifts. Use the HV0 command to go back to FC detection mode.

Important: Total Pressure measurements are disallowed when the CDEM is activated (TP_Flag is cleared as soon as the CDEM is biased). Please see the TP command for details.

Detector Programming Tips

- Use the ElecMult LED to visually inspect the status of the CDEM during programming.
- Use the HV? command to query the type of detector that is currently active. The CDEM is active if a non-zero response is returned to the computer.
- Check the value of STATUS as returned after the HV command execution: Bit 3 provides immediate information about the success of the command.
- The HV command checks for the presence of a CDEM option in the RGA ECU before execution starts and an error is reported if no CDEM is available. (Please see EM query command for details.)
- It is possible to activate the CDEM if the filament is not emitting electrons, but the CDEM will be deactivated by any overpressure that shuts-down the filament.
- The correct operation of the electrometer can be tested using the Error Reporting command ED?.
- The scan rates and signal-to-noise ratios for the different NF settings of the electrometer are listed in a table in the Electrometer section of the “RGA Electronics Control Unit” chapter.
- When using the RGA Windows program to operate the RGA, the **Scan Speed** parameter setting available in the Scan Parameter Setups of the Scan menu is used to set the NF parameter value in the RGA ECU according to the equation: **NF = ScanSpeed - 1**.
- Use the CA command to readjust the zero of the detector every time the detector settings are changed (i.e. after changing the NF parameter setting or changing detector type). This is particularly important if the new settings have not been used in a long time or since the unit was turned on or recalibrated with the CL command.

- Follow all recommended procedures for the operation of the CDEM. Consult the RGA Maintenance chapter for complete CDEM Care and Handling information.

Setting up Analog Scans

Analog scanning is the most basic operation of the RGA as a quadrupole mass spectrometer. During analog scanning the quadrupole mass spectrometer is stepped at fixed mass increments through a pre-specified mass-range. The ion current is measured after each mass-increment step and transmitted to the host computer over RS232.

Analog scans are triggered with the SC command. The scan parameter can be set for single, multiple and continuous scanning operation. The mass range for the scan is set in advance with the commands MI (Initial Mass) and MF (Final Mass) and the mass-increments are fixed with the command SA. Scan rate and detection limits are pre-programmed by the NF (Noise Floor) setting. A current value is transmitted for MI and after each mass increment through MF for a total of $(MF-MI) * SA + 1$ measurements (See AP query command). For maximum data throughput, the ion currents measured are represented as integers in units of 0.1 fA, and transmitted directly in Hex format (four byte integers with 2's complement format and Least significant byte first).

The detector settings (i.e. detector type and electrometer's noise-floor setting) to be used during the scans must be selected in advance with the NF and HV commands. The zero of the RGA's ion detector is automatically readjusted at the beginning of each analog scan so that the baseline is centered around zero. (The offset correction factor calculated and stored in memory, will then be automatically used to correct all currents measured (i.e. including those from single mass and total pressure measurements) under the same detector settings)

The internal scan parameters used by the firmware to step the RF during the scan, are checked and corrected at the beginning of the scan to make sure that the correct RF levels (i.e. as specified by the last Peak Tuning procedure) are programmed on the RF rods as a function of mass.

Important

- The detector's zero and the internal scan parameters are checked and corrected at the beginning of each scan resulting in a slight delay before the scan actually starts.
- The measurements are performed with the detector that is active at the time the scan is triggered.
- A Total Pressure measurement is performed at the end of each scan and transmitted out to the host computer. In the event where the CDEM is turned on, the total pressure returned from the ECU is 0.00. (Please see AP and TP Commands).

Setting up an analog scan

The following list of commands sets a scanning range of 10 to 150 amu, the fastest scan rate (minimum averaging), 0.1 amu steps, and, after checking the number of currents to be measured per scan (not including total pressure), it triggers 10 scans under those conditions. Each one of the 10 scans transmits 1401 scan currents and one total pressure current, and each current is 4 bytes long.

MI10 Initial mass = 10 amu.

MF150 Final mass = 150 amu.

NF7 Fastest scan rate selected.

SA10 Steps/amu = 10.

AP? Analog Points query. The number 1401 is echoed. Add one for total pressure.

SC10 Analog Scan trigger: 10 scans are generated and transmitted.

Analog Scan Programming Tips

- It is good programming practice to follow each command that sets a parameter with a query of the parameter setting. For example, the first command in the list should be followed by a MI?, and a number 10 should be echoed by the RGA.
- Notice that MI and MF are shared by analog and histogram scans.
- Any command sent to the RGA during scanning will immediately halt the scanning action and clear the RGA's transmit buffer. Remember to also clear the computer's receive buffer to reset the communications. The new command responsible for stopping the scan will be executed!
- The RGA has the ability to store a complete scan in its output buffer. The scan remains in memory until all the data is transmitted out to the host computer over RS232. As a result of the high acquisition rate of the RGA there might be a delay between the time at which the data is collected by the RGA ECU and the time at which a complete spectrum is displayed by the host computer. The time lag between data acquisition and display depends on a large number of factors including the scan rate (NF setting) of the RGA, the host computer's processing speed, and the amount of handshaking activity over the RS232 lines. As computers get faster, they will be able to catch up with the RGA data acquisition speed and this problem will no longer need any consideration.
- Before a new scan starts the RGA checks its internal memory to make sure that no data from any previous scan is pending to be transmitted. If data is still pending, the RGA must finish transmitting it before the new scan can start. This process may result in a delay from the time the scan trigger is received to the time it actually starts. Using the SC1 command and waiting until the whole scan data stream is transmitted back to the host computer will minimize the problems that are associated to this feature.
- Perform a complete **Peak Tuning** procedure on the RGA ECU if the peaks in the spectrum do not appear at their correct mass values (Consult the Peak Tuning section in the RGA Tuning chapter).

Setting up Histogram Scans

A Histogram (Bar Mode) Scan consists of a succession of individual single mass measurements over a pre-specified mass range. A single value is used to represent the peak heights at each integer mass within the range. Histogram scanning is one of the most commonly used modes of operation for the RGA. Its two main advantages are a faster scan rate than analog scans, and a reduced amount of data being exchanged during the scan.

Histogram scans are triggered with the HS command. The scan parameter can be set for single, multiple and continuous scanning operation. The mass range for the scan is set in advance with the commands MI (Initial Mass) and MF (Final Mass). A current value is transmitted for each integer mass value between MI and MF for a total of (MF-MI +1) measurements (See HP command). For maximum data throughput, ion currents are represented as integers in units of 10^{-16} Amps, and transmitted directly in hex format (four byte integers, 2's complement format, Least Significant Byte first).

The detector settings (i.e. detector type and electrometer's noise-floor setting) to be used during the scans must be selected in advance with the NF and HV commands. The zero of the RGA's ion detector is automatically readjusted at the beginning of each histogram scan so that the baseline is centered around zero. The offset correction factor calculated and stored in memory, will then be automatically used to correct all currents measured (i.e. including those from single mass and total pressure measurements) under the same detector settings.

The internal scan parameters used by the firmware to step the RF during the scan, are checked and corrected at the beginning of the scan to make sure that the correct RF levels (i.e. as specified by the last Peak Tuning procedure) are programmed on the RF rods as a function of mass.

Important

- The detector's zero and the internal scan parameters are checked and corrected at the beginning of each scan resulting in a slight delay before the scan actually starts.
- The measurements are performed with the detector that is active at the time the scan is triggered.
- A Total Pressure measurement is performed at the end of each scan and transmitted out to the host computer. In the event where the CDEM is turned on, the total pressure returned from the ECU is 0.00. (Please see AP and TP Commands).

Setting up a histogram scan

The following list of commands sets a scanning range of 1 to 50 amu and the slowest scan rate, and, after checking the number of currents to be measured per scan (not including total pressure), it triggers a single scan under those conditions. During the scan, 50 scan currents and one total pressure current are transmitted to the computer, and each current is 4 bytes long.

MI1 Initial mass=1 amu.

MF50 Final mass=50 amu

NF0 Slowest scan rate selected.

HP? Histogram Points query. The number 50 is echoed. Add one for total pressure.

HS1 Histogram Scan trigger: 1 scan is collected and transmitted.

Histogram Scan Programming Tips

- It is good programming practice to follow each command that sets a parameter with a query of the parameter setting. For example, the first command in the list should be followed by a MI?, and a number 1 should be echoed by the RGA.
- Notice that MI and MF are shared by analog and histogram scans.

- Any command sent to the RGA during scanning will immediately halt the scanning action and clear the RGA's transmit buffer. Remember to also clear the computer's receive buffer to reset the communications. The new command responsible for stopping the scan will be executed!
- It is good practice to perform an analog scan before triggering a large set of histograms to assure the correct peak tuning (i.e. correct peak locations and widths) of the quadrupole mass filter. Perform a complete Peak Tuning Procedure as described in the RGA Tuning chapter of this manual if significant shifts in the peak locations are observed.
- The RGA has the ability to store a complete scan in its output buffer. The scan remains in memory until all the data is transmitted out to the host computer over RS232. As a result of the high acquisition rate of the RGA there might be a delay between the time at which the data is collected and the time at which a complete spectrum is displayed by the host computer. The time lag between data acquisition and display depends on a large number of factors including the scan rate (NF setting) of the RGA, the host computer's processing speed, and the amount of handshaking activity over the RS232 line. As computers get faster, they will be able to catch up with the RGA data acquisition speed and this problem will no longer need any consideration.
- Before a new scan starts, the RGA checks its internal memory to make sure that no data from any previous scan is pending to be transmitted. If data is still pending, the RGA must first finish transmitting the stored data before the new scan can start. This process may result in a delay from the time the scan trigger is received to the time it actually starts. Using the HS1 command and waiting until the whole scan data stream is transmitted back to the host computer will minimize the problems that are associated to this feature.

Single Mass Measurements

Single mass measurements are triggered with the MR command. The parameter is the **integer** mass number (mass-to-charge ratio in amu units) at which the measurement is performed.

The type of detector and noise-floor settings to be used by the measurement must be selected in advance with the NF and HV commands.

The precision and duration of the measurement are totally determined by the NF parameter value. The scan rates and signal-to-noise ratios for the different NF settings of the electrometer are listed in a table in the Electrometer section of the "RGA Electronics Control Unit" chapter. The command execution time includes some initial time spent waiting for the Quadrupole Mass Filter and the electrometer response to settle.

As usual, a compromise must be made between signal-to-noise and measurement time.

The ion current is expressed in the usual format: 4 byte long, 2's complement integer in units of 10^{-16} A, with Least Significant Byte transmitted first.

Important:

- During a Single Mass Measurement the RGA performs a "**Miniscan**" around the mass requested, and the **maximum current value** measured is **sent out over RS232**. The

scanning procedure, referred to as **Peak-Locking**, is designed to measure peak currents for individual masses in a mass spectrum without being affected by drifts in the mass scale calibration. The Miniscan covers a 0.6 amu range centered at the mass requested, and selects the maximum current from 7 individual measurements performed at 0.1 amu mass increments.

- The detector settings (i.e. type of detector and noise-floor setting) to be used during the measurement must be selected in advance with the NF and HV commands; otherwise, the measurements are performed with the detector settings that are present at the time the scan is triggered.
- The ion detector can be zeroed, prior to the measurements, performing an analog or histogram scan or using the CA command, under the same detector settings (An offset-correction factor is calculated and stored in memory that it is then automatically used by the Miniscan procedure to correct all ion currents measured). The CA command will also update the internal scan parameters to assure that the correct RF levels (i.e. as specified by the last Peak Tuning procedure) are programmed on the RF rods as a function of mass during the Miniscan.

Single Mass Measurement example

The following list of commands can be used to perform a single mass measurement at 28 amu. First, the electron multiplier is turned off and the FC is connected to the electrometer, the noise floor is set to the maximum averaging (best signal-to-noise ratio and longest measurement time), the zero of the detector is readjusted, and the measurement is triggered. The single current value returned by this command is the maximum current in the 28 +/-0.3 amu region of the mass spectrum, and must be corrected with a sensitivity factor to obtain the actual partial pressure reading at mass 28.

Important: The RF/DC on the QMF are left at 28.3 amu at the end of this measurement, and the MR0 command can be used to turn them off.

Important: The CA command turns off the RF/DC at the end of its execution.

- HV0 High Voltage CDEM = 0 Volts, FC detection enabled.
- NF0 Maximum averaging (slowest scan rate) selected.
- CA Readjust the zero of the detector for clean baseline and update the internal scan parameters.
- MR28 Single measurement triggered @ 28 amu. A single current value is returned and the RF/DC are left at 28.3 amu. Collect the 4 byte current value returned.(Use sensitivity factor to convert it to pressure value.)
- MR0 Turn off the RF/DC on the QMF rods when done measuring.

Single Mass Measurement programming tips

- Single mass measurements are very commonly used in program loops where several different masses are monitored in a merry-go-round fashion and their partial pressures displayed as a function of time.
- The outputs provided by a set of single mass measurements are often used in process control programs to control alarms, analog and digital outputs, and relays. For example:

- The output of a D/A converter can be linearly related to the readings obtained at a certain mass.
- A relay switch can be closed whenever another mass concentration goes above a certain level.
- A digital output can be set high when a third mass goes under a minimum acceptable partial pressure value.
- For best accuracy of results, it is best to perform all consecutive mass measurements in a set with the same type of detector and at the same noise floor (NF) setting. Fixed detector settings eliminate settling time problems in the electrometer and in the CDEM's HV power supply.
- It is good practice to perform an analog scan before triggering a long set of measurements to assure the correct tuning (i.e. correct peak locations and widths) of the quadrupole mass filter. Perform a complete Peak Tuning Procedure as described in the RGA Tuning chapter of this manual if shifts in the peak locations are observed.
- The RF/DC voltages are not turned off at the end of a measurement. **Use the MR0 command at the end of a set of measurements and before quitting a program to make sure the RF/DC voltages are deactivated completely.**

Total Pressure Measurements

The RGA might be thought of as a Total Pressure Ionization gauge with a mass analyzer interposed between the ionizer and the detector. Thus, by disabling the mass-discriminating action of the analyzer section, it is possible to use the RGA as a total pressure ionization gauge.

Total pressure measurements are automatically requested at the end of each analog and histogram scan, and can also be triggered directly by the user with the TP? command. The response of the RGA to a Total Pressure measurement request depends on the status of **TP_Flag** at the time the measurement is requested:

TP_Flag : 1 => The measurement is performed and the total ion current is transmitted.

TP_Flag : 0 => No actual measurement is performed but a null current is still sent out over RS232.

TP_Flag is set upon a power-on reset and cleared while the CDEM is activated. It can also be toggled on/off by the user with the TP command.

The total ion current measured by the electrometer is transmitted in the standard format : Integer in units of 10^{-16} A, 4 Bytes long, 2's complement format, with the Least significant byte transmitted first.

Note: While performing a total pressure measurement the RF in the quadrupole mass filter is set to 1 amu and the DC bias is zeroed. All ionic species have stable trajectories down the filter under those conditions and reach the ion current detector with different efficiencies.

<p>Important: The sensitivity factor for the TP measurements is highly mass dependent. The additional mass discrimination that takes place in the filter results in the mass dependence of the RGA readings being very different from that of the Bayard Alpert</p>
--

gauge readings. **Expect to see deviations between the two gauges as the composition of a residual gas changes.**

Total Pressure measurement example

The following list of commands is an example of a total pressure measurement setup. The first step sets up the FC as the detector, and automatically sets the TP_Flag = 1. The second step triggers a total pressure measurement in the RGA ECU. The total current returned to the computer can be converted into a pressure using a mass dependent sensitivity factor.

HV0 High Voltage CDEM = 0 Volts, FC detection activated, TP_Flag = 1.

TP? Total pressure measurement trigger. Total ion current is returned.

Total Pressure measurement programming tips

Use the TP query command to check the total pressure with the FC prior to turning on the CDEM. Do not turn on the CDEM if the pressure is too high! **See the CDEM Handling and Care recommendations, in the RGA Maintenance chapter, for details.**

There is no query for the TP_Flag value. If the status of the flag is unknown prior to requesting a Total Pressure measurement, use TP1 to set the flag or TP0 to clear it as needed.

TP_Flag is cleared whenever the CDEM is turned on to protect the multiplier from large ion currents. TP1 can be used to reset the flag to one after making sure the total pressure is in a “safe” range for the CDEM.

The sensitivity of the RGA for total pressure measurements will usually be affected after mass axis recalibrations (i.e. Peak Tuning). Check the sensitivity calibration after any peak tuning procedure.

Storing Information in the RGA ECU

In order to make the RGA a stand-alone mass spectrometer, four parameter storage commands can be used to store ECU-specific information in the instrument's non-volatile memory.

The ECU specific parameter values that can be stored are:

SP: Sensitivity factor for partial pressure measurements, generally for nitrogen or argon. See SP command.

ST: Sensitivity factor for Total Pressure measurement, generally for nitrogen or argon. See ST command.

MV: CDEM High Voltage setting that corresponds to the gain stored by MG. See MV command.

MG: CDEM gain at the HV setting stored in MV. See MG command.

See the **Parameter Storage** commands list in the next section for details.

Important:

- The Parameter Storage commands are used by the RGA Windows software to store and retrieve the partial and total pressure sensitivity factors, and the gain and voltage settings of the CDEM calculated and used by the program.
- The parameter values are not used internally by the RGA to correct for sensitivity or gain, they are simply stored so they can be read and used by any computer connected to the RGA ECU.
- MV and MG are only available in units with the CDEM option (Opt01) installed (See MO command for details) and usually store a calibrated pair of [gain, high voltage] values for the CDEM.

Programming example

The following list shows a typical application of the storage commands to save ECU specific information in the RGA ECU. The first line stores a partial pressure sensitivity factor of 0.1mA/Torr, the second line stores into memory a total pressure sensitivity of 0.02mA/Torr, and the last two lines store a [1400V | 10,000 gain] calibrated pair for the CDEM.

```
SP0.1    Partial pressure Sensitivity= 0.1 mA/Torr.  
ST.02    Total pressure Sensitivity = 0.02 mA/Torr.  
MV1400   CDEM HV setting (for MG gain): 1400 V.  
MG10     CDEM gain (@MV setting)=10,000x.
```

Programming the Quadrupole Mass Filter

Use the ML (Mass Lock) command to activate the quadrupole mass filter (QMF) and center its pass-band at any mass number within the available range. The command ML is included for the convenience of users who wish to use the RGA as a mass filter. The QMF is parked at the mass requested but no actual measurements take place. The command's parameter can be a real number and the step resolution is 1/256 amu.

The command execution involves two steps:

1. The RF/DC levels corresponding to the mass requested are calculated and set on the QMF rods based on the mass axis calibration parameter values specified by the last Peak Tuning procedure.
2. A firmware driven algorithm is then automatically enabled to stabilize the voltage output of the RF Driver's controller against temperature fluctuations.

The net result is **very stable RF/DC levels** that are highly insensitive to the operating conditions of the RGA ECU.

Important: The RF/DC stabilization algorithm (Step 2 above) remains active as long as no new commands are detected by the RGA ECU. Once a new command is received, stabilization stops, and the new command is executed.

Use the ML0 command to turn off the RF/DC bias when finished performing measurements and before quitting the program controlling the RGA.

QMF programming example

- ML28 Activate the mass filter and center its pass band at 28 amu
- ML42.50 Activate the mass filter and center its pass band at 42.50 amu.
- ML0 Deactivate the QMF. (same as MR0 command)

QMF Programming tips

- Take advantage of the stabilization feature of the ML command whenever possible. For example: Do not send any new commands to the RGA ECU once the QMF has been set to the specified mass value, or otherwise recall the ML command, whenever practical, to refresh the QMF RF/DC settings.
- A typical application of the ML command involves monitoring a single mass concentration looking directly at the linear output of the CDEM anode with a boxcar or transient digitizer.
- Use the ML0 command to turn off the RF/DC bias when finished performing measurements and before quitting the program controlling the RGA.
- It is good practice to perform an analog scan before using the ML command to assure the correct tuning (i.e. correct peak locations and widths) of the quadrupole mass filter. Perform a complete Peak Tuning Procedure as described in the RGA Tuning chapter of this manual if shifts in the peak locations are observed.

Error Checking the RGA

Several firmware-driven **checks** automatically test the RGA when the unit is turned on, and continuously monitor the internal workings of the instrument. A “Background Filament Protection Mode” is activated when the filament is turned on to protect the delicate filament (and CDEM) from accidental overpressure. Several commands can be used to trigger hardware tests on the ECU. Any one of the internal checks just described can detect and report errors, and it is the responsibility of the user to constantly monitor the RGA ECU for error reports.

There are two ways to detect the presence of errors in the RGA:

1. **Visually:** Inspecting the red LED’s on the rear panel of the ECU.
2. The Error LED is turned on whenever a hardware problem is detected, and it flashes twice if a communications error is generated during programming.

3. The Burnt and Leak LED's indicate specific filament problems and are turned on, in addition to the Error LED, whenever the ionizer's emission is internally shut down or not established as requested.
4. **Error Queries:** Queering the **Error Bytes** with the **Error Reporting** commands. The "Error Byte Definitions" section of this chapter describes the different error bytes used to store the results of the internal checks. The "Error Reporting Commands" query the error bytes and are used to quickly diagnose problems.

Important: The **RGA Windows** software supports all the Error Reporting commands and routinely monitors the Error Bytes. Detected errors are immediately reported to the user and identified based on Error Codes. See the RGA Troubleshooting chapter for recommended solutions to the problems.

The **STATUS error byte** is the gateway to error diagnosis:

Important: The RGA is free of detected errors as long as the STATUS byte is clear (no bits set).

Each bit of the STATUS byte reflects the result of a different type of **internal check**. Each internal check involves **several** different **tests** on a component of the RGA (See the RGA Troubleshooting Chapter for details). The results of the specific tests are stored in check-specific **error bytes**. All error bytes can be queried by the computer, using the Error Reporting commands, to find out which bits are set.

STATUS Bit	Internal Check^(a)	ERROR Byte^(c)	Query^(d)
7	not used	N.A.	N.A.
6	24V External P/S ^(b)	PS_ERR	EP?
5	Electrometer ^(b)	DET_ERR	ED?
4	Quadrupole Mass Filter ^(b)	QMF_ERR	EQ?
3	Electron Multiplier	CEM_ERR	EM?
2	not used	N.A.	N.A.
1	Filament	FIL_ERR	EF?
0	Communications	RS232_ERR	EC?

(a) RGA component checked. Each check involves several tests on the component.

(b) Internal checks automatically performed upon a power-on-reset

(c) Error bytes that store the results of the tests for each type of internal check.

(d) The Error Reporting command that queries the error byte.

The Error LED is immediately turned on if any one of the bits 1-7 of STATUS is set. Bit 0 of STATUS reports communications errors and the Error LED is only flashed twice when the bit is set.

The STATUS Byte should be queried regularly by the programming software (ER? command.)

Commands that involve hardware control (such as Ionizer Control commands) do diagnostic checks on the hardware as they are executed. Since the command execution time can be rather long, the RGA prompts the end of execution by sending back the value of the STATUS byte to the computer. *Always check the STATUS Byte value returned for possible errors.*

If one or more bits of the STATUS byte are found set, the specific error bytes (PS_ERR, DET_ERR, QMF_ERR, CEM_ERR, FIL_ERR, and RS232_ERR) must be queried individually to diagnose the problem.

Error Diagnosis Example #1

The RGA is powered up and, after the automatic internal checking is over, the Power LED is turned off and the Error LED is turned on. The problem is immediately diagnosed visually as a failure in the 24V External P/S check. A multimeter could be used to check the output of the external power supply and determine the nature of the problem; however, the computer could also be used to diagnose the problem using the query commands:

The ER query command returns a STATUS Byte with bit 6 set indicating a 24V P/S problem. The EP query command is then used to query PS_ERR. Bit 6 of PS_ERR is found set (Error Code: PS6) indicating that the P/S output is less than the acceptable minimum of 22 V.

This error is also immediately reported by the RGA Windows software as an Error Code: PS6, and the RGA Troubleshooting section can be consulted to solve the problem.

Error Diagnosis Example #2

The RGA is idling between scans, waiting for commands from the computer, when suddenly a vent-valve is accidentally opened and the vacuum system is pressurized. The Background Filament Protection mode immediately detects the problem and turns off the filament. The change is easily detected because the Filament LED turns off, and the Error and Leak LED's simultaneously turn on.

A visual inspection of the red LED's is all that is needed in this case to detect and diagnose the problem; however, a computer could do the same diagnosis with the help of the query commands:

The ER? command, used to monitor the STATUS byte regularly, returns a non-zero byte value. Further analysis, shows that bit 1 is set indicating a filament problem. The EF? command is then used to read in the value of FIL_ERR. Bit 6 is found set indicating that the filament was unable to set the requested emission current and had to be shut down (Error Code: FL6). The problem is quickly diagnosed as an overpressure using the RGA Troubleshooting chapter directions.

The error is also immediately reported by the RGA Windows software as Error Code: FL6, and the RGA Troubleshooting section can be consulted to solve the problem.

Error Diagnosis Example #3

The RGA is turned on and, after all the internal checks are performed, the green Power LED and the Error LED are turned on. The red LED signals the operator that a problem was detected. A 24V P/S error is not expected since the Power LED is on. The ER? command returns a STATUS byte with bit 4 set, pointing to a quadrupole mass filter problem. The command EQ? is used to read in the QMF_ERR byte. Bit 7 is found set indicating that the RF driver is unable to set the maximum RF value available to the RGA (Error code RF7 in Troubleshooting Chapter). A quick visual inspection of the RGA ECU shows that the ECU is not pushed all the way into the probe and no actual connection exists between the rods and the RF driver.

This error is also immediately reported by the RGA Windows software as Error Code: RF7, and the RGA Troubleshooting section can be consulted to solve the problem.

Error Diagnosis Example #4

The user notes that the Error LED flashes every time the ID? command is sent to the RGA and the ID string is never returned (i.e. receive timeout). The STATUS byte returned by the ER command has the bit 0 set as expected for a communications problem. The specific communications problem is diagnosed using the EC? command. Bit 0 of RS232_ERR is found set indicating that a bad command is being detected by the RGA. The user checks the communications program and finds out that, due to mistyping, the IM? string is being sent to the RGA instead of ID?. The problem is easily corrected.

Error Checking Programming tips

- Keep a close eye on the Error LED's while programming the RGA. Diagnose problems as soon as they are detected.
- Even though a lot of internal checks are performed by the microprocessor, not all possible internal error conditions are accounted for.
- The values of the Error Bytes often change after an Error Byte query command is executed. Some query commands update the byte value after performing a fresh test on the hardware, while others clear error bits, after they are read, to provide a clean error-reporting slate. Please see the Error Reporting Commands list for details.
- It is good programming practice to check the value of the STATUS byte whenever it is returned at the end of command execution.
- In cases where a hardware error is reported at the end of a command attempt the command one more time before declaring a hardware problem.

RGA Command Set

This section lists and describes the commands of the RGA's Command Set. The commands are separated into several lists, based on their functions. They are each identified by a header that describes the command's syntax (with the acceptable parameter values), the command's function, and the information returned (echo) to the computer during execution.

The RGA commands are ASCII character strings consisting of a two letter (case insensitive) command name, a parameter, and a carriage return terminator.

Note: The carriage return character, decimal ASCII value=13, is represented throughout this manual with the symbol <CR>. All command strings must be terminated with this character in order to be acknowledged by the RGA.

The two letter mnemonic in each command sequence specifies the command name. The rest of the sequence consists of parameters. Three types of parameters are allowed: numbers, asterisk (default param), and question mark (query). Not all commands accept all types of parameters, and some need no parameters at all.

In general, number parameters can be real or integer; however, some commands will only accept integers. Commands that accept only integers are recognized because the numbers used to specify their parameter range do not have a fractional part.

The maximum mass number recognized by the RGA is model dependent and is represented by **M_MAX**: 100 for the RGA100, 200 for the RGA200, and 300 for the RGA300.

With a few exceptions, the data returned by most query commands is a string of ASCII characters terminated by a linefeed (<LF>, decimal ASCII value=10) and a <CR> terminator: string<LF><CR>.

Ion currents are represented as integers in units of 10^{-16} Amps, and transmitted directly in Hex format: four byte integers, 2's complement format, Least Significant Byte first.

Initialization Commands

ID?

Description: Identification query.

Echo: ID string.

Use to identify the RGA ECU connected to the host computer.
The RGA returns the ID string (ASCII format):

SRSRGA###VER#.##SN#####<LF><CR>

The three string parameters, in the exact format shown above, correspond to:

1. Model number (=M_MAX): 100 for RGA100, 200 for RGA200 and 300 for the RGA300.
2. Firmware version (for example: 0.23).
3. Serial Number of the unit (5 digit format).

The ID command is used for a variety of purposes:

- Make sure the RGA is powered up and ready to go.
- Check the quality of the RS232 connection to the host computer.
- Check the user's communication software to make sure it is communicating properly with the RGA.
- Check the serial numbers of the RGA ECU's connected to the computer's serial ports. The unique serial number attached to each ECU can be used for identification purposes avoiding the problems caused by cable swapping in the RS232 connections under multiplexed operation, or ECU swapping in the vacuum system.

Parameters: Only one possible format:

ID?

Error checking:

Only a query format is accepted. Anything else results in a Bad-parameter error.

INO, IN1, IN2

Description: Initialization command

Echo: STATUS Byte

Initialize the RGA to a known state.

Three different levels of initialization are available.

Command execution times vary depending on the pre-existing ionizer conditions. The end of the command execution is prompted to the host computer returning the STATUS byte over RS232.

Parameters:

IN0: Initialize communications and check the ECU hardware.

- The input and output data buffers are emptied (all communications are disabled while this happens).
- Bit 0 of STATUS and RS232_ERR are cleared
- A fresh check of the ECU hardware, including the 24V P/S, the Electrometer and the QMF RF P/S, is performed and the necessary error bytes are updated.

IN1: Reset the RGA to its factory default settings.

In addition to the above, the RGA is reprogrammed to its default (i.e. Factory preferred) values:

- Total Pressure measurement. is enabled: TP_Flag =1
- Default parameter settings are selected for: MI (1), MF (M_MAX), SA (10), NF (4), IE (1), EE (70), and VF (90).
- The filament's electron emission setting is left unmodified and the ionizer is biased to default voltages if necessary.

IN2: Activate Standby mode.

In addition to the above:

- The filament and the CDEM are turned off.

Error Checking:

The command accepts no default or query parameter values.

The absence of a parameter is treated as a bad-parameter error.

Ionizer Control Commands

*DGparam, param: 0 - 20,**

Description: Ionizer Degas command

Echo: STATUS error byte (unless command is stopped before completion, or param=0).

DEGAS the ionizer by heating and electron stimulated desorption. The parameter represents the desired DEGAS time in minutes and includes a one minute initial ramping time.

Warning: Repeated degassing will considerably limit the lifetime of the filament. Whenever possible replace a Degas procedure with a thorough probe and vacuum system bakeout (See Probe Bakeout in RGA Maintenance Chapter).

Important: The Electron Multiplier is turned off at the beginning of a Degas cycle, and left unbiased at the end, for protection.

During the DEGAS process, the electron energy is set to 400 eV, and the electron emission current is ramped to 20 mA over a 1 minute period. The high ionizer energy (c.a. 8W) combined with a large flux of highly energetic electrons degasses the ionizer in a process known as electron stimulated desorption.

Degassing is done in a very controlled fashion. The electron emission current is ramped slowly to avoid sudden bursts of pressure into the vacuum chamber, and the filament is constantly checked to make sure it is always protected from a harsh environment. If a problem is found in the filament operation at any time, degassing is interrupted and the filament is left without any electron emission current.

The degassing process involves several steps:

1. The FIL_ERR Byte is checked to make sure it is zero. If not zero, jump to 12.
2. The filament status is memorized so it can be restored at the end of the command (step 10).
3. The Degas_LED is turned on.
4. The FC and CDEM anode are connected to ground, and (if necessary) the CDEM is turned off.
5. The electron energy is set to 400 eV.
6. The emission current is ramped from 1 to 20 mA over a period of one minute (with the filament checked every 3 seconds)
7. The rest of the degas time is spent at full emission current and with the filament checked once every second.

If a filament check fails at any time the following steps are taken automatically: filament is turned off, Degas_LED is turned off, jump to step 12).

8. At the end of the time specified by the parameter (and if no problems were encountered) the Degas_LED is turned off.
9. Ionizer goes back to pre-Degas configuration
10. The electron emission current is reprogrammed to its pre-Degas value and background filament protection is reenabled.
11. The Filament LED is updated.
12. The STATUS byte is sent out to the host computer to indicate the DEGAS process is over.

Any command received before degassing is over will stop the process immediately without the STATUS byte being echoed to the computer. During degassing a check for new commands is done once a second, so a time margin must be allowed once the stop command is issued for the Degas command to react to it. Some more time (a few seconds) must be provided to let the pre-degas electron emission current be reestablished at the end.

Parameters:

DG0: Do nothing command. Commonly used to stop degassing. Nothing is echoed over RS232.

DGparam, param: 0-20: The parameter represents the degas time in minutes. The first minute is used to ramp the current up to 20 mA.

DG*: The default time is used to degas.

Default=3 (minutes)

Error Checking:

Number parameters must be within the accepted range, and must be integers.

No parameter (i. e. DG) is treated as a parameter error.

No queries are allowed.

*EEparam, param: 25 - 105, *, ?*

Description: Electron Energy (eV).

Echo: STATUS error byte or query response.

Set the Electron Impact Ionization Energy of the ionizer. The parameter represents the desired electron ionization energy in units of eV.

If the filament is emitting electrons at the time the command is invoked, the repeller voltage is immediately reconfigured to provide the desired electron energy, while the ion energy and electron emission currents remain unaffected. If the filament is off, the new electron energy setting is stored in memory for the next time the filament's emission is activated

Command execution times vary depending on the pre-existing ionizer conditions. The end of the command execution is prompted to the host computer by sending out the STATUS byte over RS232.

Note: The Electron Impact Ionization Energy is set to the default value when the unit is turned on.

Important: The repeller grid and the focus plate are only biased while the filament is emitting electrons.

Parameters:

EEparam, param: 25-105: The parameter represents the electron impact ionization energy in eV.

EE*: The default Electron Energy value is used to run the command.

Default: 70 (eV)

EE?: Query. The electron energy parameter setting is returned over RS232 in ASCII format.

Error checking:

Number parameters must be within the accepted range and must be integers.

The absence of a parameter (i. e. EE) is treated as a parameter-error.

*FLparam, param: 0.00 - 3.50, *, ?*

Description: Electron emission current (mA).

Echo: STATUS error byte or query response.

Set the electron emission current level in the ionizer. The parameter represents the desired electron emission current in units of mA.

When a finite emission current is requested, the RGA biases the ionizer's repeller grid and focus plate, and activates the filament's heater until the requested electron current is established.

A null parameter value, turns off the filament and grounds the ionizer's repeller grid and focus plate.

Command execution times vary depending on the pre-existing ionizer conditions. The end of the command execution is prompted to the host computer sending out the STATUS byte over RS232.

The Filament LED reflects the ionizer's emission status at all times.

A firmware-driven "**Filament Protection Mode**" monitors the performance of the filament while it is emitting electrons and if a problem is detected at any time, the heater is immediately shut down and the problem is reported through the error bytes and the error LED's (see below).

<p>WARNING: The pressure in the chamber must be under 10^{-4} Torr before turning the filament on!</p>
--

Important:

- The repeller grid and the focus plate are only biased while the filament is emitting electrons.
- In order to protect the filament, the emission current is defaulted to zero when the RGA is turned on.
- The CDEM is turned off by any overpressure that also shuts down the filament.

Parameters :

FL0.00: The filament is turned off and the repeller grid and the focus plate are grounded.

FLparam, param: 0.02-3.50: The parameter is the requested Electron Emission Current in units of mA. The repeller grid and the focus plate are biased, and the filament's heater is activated until the requested electron current is achieved.

FL*: The command is executed using the default parameter value.

Default: 1.00 mA

FL?: Returns over RS232 the value of Electron Emission Current (in mA) actually flowing through the ionizer.

Important: The number returned by the query command will always be very close, but rarely identical, to the current value set with the FLparam command. The difference observed will never exceed +/-0.02 mA. The value returned is the actual electron current circulating through the ionizer as internally calculated by the RGA ECU. The discrepancy is due to the finite resolution of the digital-to-analog converters used to program the ionizer's emission current.

Error Checking:

The absence of a parameter (i. e. FL) is treated as a bad-parameter error.

The STATUS byte is echoed to the host computer at the end of the command execution, and it should be checked to determine whether the requested electron emission current was successfully established. If Bit 1 of STATUS is found set, FIL_ERR should be immediately checked to identify the specific problem (See EF? command in the Error Reporting Commands list). It is good practice to attempt the command a second time before declaring a hardware problem. Once it has been set, FIL_ERR can only be cleared after successfully turning on the filament.

*IEparam, param: 0,1, *, ?*

Description: Ion Energy (eV).

Echo: STATUS error byte or query response.

Set the Ion Energy to one of two possible levels: Low (8eV) or High(12eV). The parameter represents the ion energy level: 0 for Low and 1 for High.

Since the axis of the quadrupole mass filter is at ground, the ion energy (in eV) is equal to the anode grid voltage (in Volts).

Important: The anode grid is always biased regardless of the ionizer's emission status.

Upon reset the grid level is set to the default value.

Parameters:

IE0 Low ion energy: 8 eV .

IE1 High ion energy: 12 eV.

IE*: The default Ion Energy parameter value is used to run the command.

Default: 1 => high ion energy: 12 eV

IE?: Query. The value of the anode grid parameter is returned over RS232 in ASCII format. *Note that it is the parameter value and not the actual voltage level that is returned.*

Error checking:

Number parameters can be 0 or 1 only, and must be integers.

The absence of a parameter (i. e. IE) is treated as a bad-parameter error.

*VFparam, param: 0 - 150, *, ?*

Description: Focus plate voltage (Volts)

Echo: STATUS Error Byte and query response.

Set the focus plate voltage in the ionizer. The parameter represents the magnitude of the biasing voltage (negative) in units of volts.

The ions formed inside the anode grid are extracted into the quadrupole mass filter by the negative attractive potential of the "Focus" or Extraction Plate. The plate serves the double purpose of drawing the ions away from the anode grid, and containing the ionizing electrons inside the source. Electron leakage into the filter is only detectable at low mass settings (1 to 10 amu) and can easily be eliminated biasing the focus plate at least 30V more negative than the repeller.

Careful adjustment of the voltage results in optimum coupling of the ion beam into the QMF and maximum sensitivity.

If the filament is emitting electrons at the time the command is invoked, the focus voltage is immediately reprogrammed, while the ion energy, electron energy and electron emission currents remain unaffected. If the filament is off, the new focus voltage value is stored in memory for the next time the filament's emission is activated.

Command execution times vary depending on the pre-existing ionizer conditions. The end of the command execution is prompted to the host computer sending out the STATUS byte over RS232.

Parameters:

VFparam, param: 0-150: The parameter represents the magnitude of the focus plate bias potential in Volts (*The actual bias voltage is negative*). The STATUS byte is transmitted at the end of command execution.

VF*: The default Focus plate biasing Voltage value is used to execute the command. Default: 90 (V).

VF?: Query the focus plate biasing voltage setting.

Error checking:

Number parameters must be integers within the accepted range.

The absence of a parameter (i. e. VF) is treated as a bad-parameter error.

Detection Control Commands

CA

Description: Calibrate All.

Echo: STATUS Error Byte.

Readjust the zero of the ion detector under the present detector settings, and correct the internal scan parameters against small temperature fluctuations to assure that the correct RF voltages (i.e. as specified by the last Peak Tuning procedure) are programmed on the QMF rods as a function of mass.

In order to readjust the zero of its ion detector, the RGA measures the output of its electrometer in the absence of input ion current and under the present detector settings (i.e. noise floor and detector type). The current value obtained is stored in internal memory as an offset correction factor that is automatically used by the firmware to correct all ion currents measured (i.e. including those from single mass and total pressure measurements) under the same detector settings.

Important:

- Offset correction factors for **all** the possible combinations of detector settings can be accumulated in the RGA's memory.
- **All offset correction factors are automatically cleared after a complete recalibration (CL) of the electrometer is performed, and also when the unit is turned off.**
- Use the CA command every time the detector settings are changed to values that have not been used in a long time or that were never used since the unit was turned on or recalibrated with the CL command.
- The zero of the ion detector is also automatically readjusted at the beginning of each analog and histogram scan so that the baseline is always centered around zero.

In order to correct the mass axis against peak position shifts caused by small-temperature fluctuations, the RGA characterizes the voltage output of the RF driver's control circuit, and **recalculates its internal scan parameters** to assure that the correct RF levels (i.e. as specified by the last Peak Tuning procedure) are programmed on the QMF rods as a function of mass.

Important: Use a complete Peak Tuning Procedure to correct the mass axis calibration when large temperature fluctuations are suspected. The calibration procedure triggered by the CA command cannot correct the mass axis against large temperature drifts that affect the response of the RF Driver to its controlling voltage, or the relationship between mass and RF levels in the QMF itself (i.e. due to changes in the QMF's physical dimensions).

Notes:

- This mass axis correction procedure can also be triggered at any time, by itself, using the RS and RI commands with no parameters (See Tuning commands).
- The correction procedure is also automatically performed at the beginning of all analog and histogram scans. However, no correction is performed at the beginning of single mass measurements since the extra checking would significantly extend the time it would take the measurement to be completed.
- Please see the Peak Tuning section of the RGA Tuning chapter for more details on mass axis calibration requirements under small and large temperature fluctuations in the RGA ECU.
- **Remember that the CA command turns off the RF/DC voltages at the end of execution.**

Parameters: Only one possible command format is allowed

CA

Error Checking:

An attempt to pass any parameter with CA results in a bad-parameter error being reported.

CL

Description: Calibrate Electrometer's I-V response.

Echo: STATUS error byte.

Perform a complete calibration of the electrometer's I-V response.

The calibration procedure calibrates the output of the electrometer against input current over its entire operating range, and stores a calibration table in the non-volatile memory of the RGA ECU. *Instead of simply relying on the intrinsic logarithmic I-V behavior of the electrometer, a digital logarithmic interpolation algorithm calculates the currents from the calibration curve during measurements.*

The procedure takes several seconds (longer when CDEM option is installed) and its completion is signaled to the host computer by returning the STATUS byte value.

Important:

- The electrometer is designed for maximum long term stability, however, it is good practice to recalibrate it periodically, particularly in the presence of a large change in the operating temperature of the RGA ECU.

- **All** offset correction factors previously stored in memory are cleared after a complete calibration of the electrometer is performed (see CA command for more information).

Parameters: Only one possible command format is allowed
CL

Error Checking:

An attempt to pass any parameter with CL results in a bad-parameter error being reported.

*HVparam, param: 0 - 2490, *, ?*

Description: Electron Multiplier High Voltage Bias setting.

Echo: STATUS error byte or Query Response.

Set a negative high voltage across the electron multiplier (CDEM), connect the CDEM signal output to the electrometer and reconfigure the electrometer and current measurement algorithms to handle negative electron currents. The parameter value represents the magnitude of the bias voltage in units of Volts.

<p>Warning: This command only works in ECU's with the CDEM option (Opt01) installed (See MO command.)</p>
--

Since the CDEM turns ion signals into amplified electron currents, the RGA ECU automatically reconfigures the electrometer to measure negative currents when a finite biasing voltage is selected. The current measurement algorithm is also automatically reconfigured so that the **magnitude** of the currents measured is transmitted over RS232. The host computer can then handle the amplified signals the same way it did with the positive ion currents (i.e. it does not need to flip the sign of the currents received).

The HV_LED reflects the status of the CDEM bias at all times.

Since it takes time for the CDEM and for the electrometer to settle, completion of the command is prompted to the host computer transmitting the STATUS byte value over RS232.

Important:

- Faraday Cup detection is the default setting upon a power-on reset of the RGA ECU.
- The voltage set by this command is the output of the high voltage power supply. A 1M Ω resistor is placed between that output and the CDEM's cone. CDEM's typically have an internal resistance in the order of 100-2500 M Ω , and consequently the voltage measured on the CDEM will always have a magnitude smaller than the value returned by a HV? command (i.e. the CDEM becomes part of a voltage divider in conjunction with the 1M Ω resistor).

- It is good practice to readjust the Zero of the ion detector every time the type of detector (FC or CDEM) is changed. This is particularly important if the new detector settings have not been used in a long time or since the unit was turned on or recalibrated with the CL command. See the CA command for details and more recommendations.

Parameters :

HV0: Use this parameter value to “turn off” the Electron Multiplier and enable Faraday Cup (FC) Detection. The following steps are taken:

- The biasing voltage of the CDEM is set to Zero (i.e. no ion collection and no gain).
- The electrometer is connected to the FC signal output and reconfigured to measure positive currents.
- The firmware algorithms are reconfigured to transmit the **magnitude** of the positive currents measured.
- The HV_LED is turned off.
- The STATUS Byte is sent out to prompt the end of the command

HVparam, param: 10-2490: The parameter is the magnitude of the CDEM bias voltage requested (the actual biasing voltage is negative). The following steps are taken:

- The requested biasing voltage is set on the CDEM.
- The electrometer is connected to the CDEM anode and reconfigured to measure negative currents.
- The firmware algorithms are reconfigured to transmit the **magnitude** of the negative currents measured.
- The HV_LED is turned on.
- The STATUS Byte is sent out to prompt the end of the command

HV*: The command is executed with the default parameter value.

Default: 1400 (Volts)

HV?: Returns the magnitude of the biasing voltage on the CEM.

The number returned by the query command is the actual voltage available at the output of the HV driver and will always be very close but rarely identical to the one requested with the HVparam command.

Error Checking:

The CDEM option (Opt01) must be available in the RGA ECU receiving the command or a bad-command error is reported (see MO command for details).

Number parameters must be within the accepted range, and must be integers.

No parameter (i. e. HV) is treated as a bad-parameter error.

Bit3 of STATUS (transmitted at the end of the command) reports errors in the execution of the command. CEM_ERR byte must be consulted to find out the specific problem encountered (See EM? in Error Reporting command list).

MO?

Description: Electron Multiplier Option Query.

Echo: Query Response.

Query the electron multiplier (CDEM) option in the RGA unit being programmed.

The RGA is provided standard with a Faraday Cup detector. For increased sensitivity and faster scan rates an optional CDEM is offered. The MO? command can be used to determine whether Electron Multiplier detection is an option in the RGA being programmed.

Note: See also EM? command in the Error Reporting commands list for an alternative way to query the CDEM option.

Parameters:

Query is the only possible format: **MO?**

The value returned over RS232 in ASCII format has two possible values:

0<LF><CR>	No CDEM option is available.
1<LF><CR>	CDEM option is available.

Error checking:

Command must have a query format or a bad parameter error is reported.

NFparam, param: 0 - 7, *, ?

Description: Electrometer's Noise-floor setting.

Echo: Query Response

Set the rate and detection limit for ion current measurements.

A decrease in the Noise-Floor setting results in cleaner baselines and lower detection limits during scans and measurements, but also means longer measurement and scanning times due to the reduced bandwidth of the electrometer and increased averaging.

The NF parameter must be chosen keeping in mind the strong interplay between detection limit and acquisition speed.

Histogram scans, analog scans, single-mass measurements and total pressure measurements all share the same value of NF setting during measurements.

Important: The NF parameter is set to its default value when the RGA is turned on.

It is good practice to readjust the Zero of the ion detector every time the electrometer's noise floor setting is changed. This is particularly important if the new detector settings have not been used in a long time or since the unit was turned on or recalibrated with the CL command. See the CA command for details and more recommendations.

RGA Windows note: When using the **RGA Windows** program to operate the RGA, the **Scan Speed** parameter setting available in the Scan Parameter Setups of the Scan menu is used to set the NF parameter value in the RGA ECU according to the equation: **NF = ScanSpeed - 1**.

Parameters:

NFparam, param: 0-7: The parameter represents the noise-floor level desired.

Lower parameter values correspond to lower baseline noise, better detection limits and increased measurement times.

Please refer to the Electrometer section of the RGA Electronics Control Unit chapter to obtain detailed information about detection limits and bandwidth values as a function of NF settings.

NF*: The noise-floor is set to its default value.

Default value: 4.

NF?: Returns the noise-floor setting currently used by the electrometer .

Error checking:

Number parameters must be within the specified range, and be integers.
The absence of a parameter (i. e. NF) is treated as an error.

Scan and Measurement Commands

AP?

Description: Analog Scan Points Query.

Echo: Query Response.

Query the total number of ion currents that will be measured and transmitted during an analog scan under the current scan conditions.

<p>Important: The query response does not include the extra current (4 bytes) corresponding to the total pressure measurement performed at the end of all analog scans (Please see SC command for details).</p>
--

The number of points (i.e. ion currents) returned over RS232 is calculated based on the MI, MF and SA parameter values. Number of points = $(MF - MI) * SA + 1$. The first point corresponds to the mass MI and the other $(MF-MI)*SA$ are from scanning to MF with SA measurements (steps) per amu. Each point transmitted represents an ion current and as such corresponds to 4 bytes being received by the host computer.

The AP query is used to verify that the RGA and the host computer agree on the number of bytes that will be exchanged over RS232 during the analog scan.

The total number of bytes sent out to the host computer during an analog scan is obtained multiplying by four the number returned by the AP query.

Parameters: This command is a query, and can only have one parameter format:

AP?

Error checking:

The only acceptable parameter is a question mark.

The absence of a parameter (i. e. AP) is treated as an error.

HP?

Description: Histogram Scan Points Query.

Echo: Query Response

Query the number of ion currents that will be measured and transmitted during a histogram scan under the current scan conditions.

Important: The query response does not include the extra current (4 bytes) corresponding to the total pressure measurement performed at the end of all histogram scans. (Please see HS command for details).

The number of points (ion currents) returned over RS232 is calculated based on the MI and MF parameter values. Number of points = MF - MI + 1. Each point transmitted represents an ion current and as such corresponds to 4 bytes being received by the host computer.

The HP query is used to verify that the RGA and the host computer agree on the number of bytes that will be exchanged over RS232 during the histogram scan.

The total number of bytes sent out to the host computer during an histogram scan is obtained multiplying by four the number returned by the HP query.

Parameters: This command is a query, and can only have one parameter format:

HP?

Error checking:

The only acceptable parameter is a question mark.

The absence of a parameter (i. e. HP) is treated as a Bad-Parameter error.

*HSparam, param:0 - 255, **

Description: Histogram Scan Trigger.

Echo: Ion Currents.

Execute one or multiple Histogram Scans under the present scan conditions.

The scan parameter can be set for single, multiple and continuous scanning operation.

A Histogram Scan consists of as a succession of individual mass measurements (see MR command) over a pre-specified mass range.

The mass range for the scan is set in advance with the commands MI (Initial Mass) and MF (Final Mass). The type of detector and noise-floor settings to be used during the scan must be selected in advance with the NF and HV commands. A current value is transmitted for each integer mass value between MI and MF for a total of (MF-MI +1) measurements (See HP command).

For maximum data throughput, ion currents are represented as integers in units of 10^{-16} Amps, and transmitted directly in hex format (four byte integers, 2's complement format, Least Significant Byte first).

Important:

- Any command received by the RGA in the middle of a scan will immediately stop the scan, halt transmission and clear the RGA's transmit buffer.

- The detector's zero and the internal scan parameters are checked and corrected at the beginning of each scan resulting in a slight delay before the scan actually starts.
- **A Total Pressure measurement is performed at the end of each scan and transmitted out to the host computer (Please see HP and TP Commands).**
- The measurements are performed with the detector that is active at the time the scan is triggered.

Parameters:

HS: Continuous scanning mode. The RGA produces a continuous string of histogram scans.

A new command must be sent to the RGA in order to stop the scanning activity. Once the command is received, the scan is immediately stopped, all transmission is halted and the transmit buffer is flushed (*all remaining data is lost*). The new command which stopped the scan is executed after the buffer is flushed

HS0: Do nothing command. Commonly used to interrupt continuous scanning mode.

HSparam, param:1-255: Multiple scans. The number of scans specified by the parameter is executed. Scanning is immediately stopped when a new command is received as in the case of continuous scanning.

HS*: The default parameter value is used for multiple scan execution.

Default parameter value: 1 (single scan)

Error checking:

Number parameters must be within the specified range, and be integers.

No query format is allowed

Programming Tips:

- Any command received by the RGA while scanning will immediately stop the scanning process and clear the RGA's transmit buffer. Remember to also clear the computer's receive buffer to reset the communications. The new command which stopped the scan is executed after the RGA ECU buffer is flushed.
- It is good practice to perform an analog scan before triggering a large set of histograms to assure the correct tuning (i.e. correct peak locations and widths) of the quadrupole mass spectrometer. Perform a complete Peak Tuning Procedure as described in the RGA Tuning chapter of this manual if shifts in the peak locations are observed.
- The RGA has the ability to store a complete scan in its output buffer. The scan remains in memory until all the data is transmitted out to the host

computer over RS232. As a result of the high acquisition rate of the RGA there might be a delay between the time at which the data is collected and the time at which a complete spectrum is displayed by the host computer. The time lag between data acquisition and display depends on a large number of factors including the scan rate (NF setting) of the RGA, the host computer's processing speed, and the amount of handshaking activity over the RS232 lines.

- Before a new scan starts the RGA checks its internal memory to make sure that no data from any previous scan is pending to be transmitted. If data is still pending, the RGA must finish transmitting it before the new scan can start. This process may result in a delay from the time the scan trigger is received to the time it actually starts. Using the HS1 command and waiting until the whole scan data stream is transmitted back to the host computer will minimize the problems that are associated to this feature.

*MFparam, param: 1 - M_MAX, *, ?*

Description: Final Mass (amu) of mass spectra (Analog and Histogram).

Echo: Query Response

Set the Final Mass value (in amu) for Analog and Histogram scans.

The last ion current transmitted during an Analog or Histogram scan corresponds the mass-to-charge ratio specified by the MF parameter.

Important: Note that the final mass setting is shared by both histogram and analog scans, and must be an integer number.

Parameters: Three possibilities :

MFparam, param: 1 - M_MAX: The parameter represents the final scan mass in amu units. The upper mass limit depends on the RGA model number:

The upper mass limit depends on the RGA model number: M_MAX=100 for RGA100, 200 for RGA200 and 300 for the RGA300 units.

MF*: The final mass value is set to its default value.

Default value: M_MAX=100 for RGA100, 200 for RGA200 and 300 for the RGA300.

MF?: Query the value of final mass to be measured during scans.

Error checking:

Number parameters must be within the specified range, and be integers.

The mass value set by MF must always be greater than or equal to the initial mass setting of MI or else a parameter-conflict communications error is generated.

The absence of a parameter (i.e. MF) is treated as a bad-parameter error.

*MIparam, param: 1 - M_MAX, *, ?*

Description: Initial Mass (amu) of mass spectra (Analog and Histogram).

Echo: Query Response.

Set the Initial Mass value (in amu) for Analog and Histogram scans.

The first ion current transmitted during an analog or histogram scan corresponds the mass-to-charge ratio specified by the MI parameter.

Note that the initial mass setting is shared by both Histogram and Analog scans, and must be an integer number.

Parameters:

MIparam, param: 1-M_MAX: The parameter represents the initial scan mass in amu units.

The upper mass limit depends on the RGA model number: M_MAX=100 for RGA100, 200 for RGA200 and 300 for the RGA300.

MI*: The initial mass value is set to its default value.

Default value: 1.

MI?: Returns the value of initial mass to be measured during scans.

Error checking:

Number parameters must be within the specified range, and be integers.

The mass value set by MI must always be less than or equal to the final mass setting MF or else a parameter-conflict communications error is generated.

The absence of a param (i.e. MI) generates a bad parameter error .

MRparam, param:0 - M_MAX

Description: Single Mass Measurement

Echo: Ion Current

Execute a single ion current measurement at a specified mass setting. The parameter is the **integer** mass number (mass-to-charge ratio in amu units) at which the measurement is performed.

The type of detector and noise-floor settings to be used by the measurement must be selected in advance with the NF and HV commands.

The precision and duration of the measurement are totally determined by the NF parameter value. The scan rates and signal-to-noise ratios for the different NF settings of the electrometer are listed in a table in the Electrometer section of the “RGA Electronic Control Unit” chapter. The command execution time includes some initial time spent waiting for the Quadrupole Mass Filter and the electrometer response to settle. As usual, a compromise must be made between signal-to-noise and measurement time.

The ion current is expressed in the usual format: 4 byte long, 2's complement integer in units of 10^{-16} A, with Least Significant Byte transmitted first.

Important:

- During a Single Mass Measurement the RGA performs a “**Miniscan**” around the mass requested, and the **maximum current value** measured is **sent out over RS232**. The scanning procedure, referred to as **Peak-Locking**, is designed to measure peak currents for individual masses in a mass spectrum without being affected by drifts in the mass-axis calibration. The Miniscan covers a 0.6 amu range centered at the mass requested, and selects the maximum current from 7 individual measurements performed at 0.1 amu mass increments.
- The detector settings (i.e. type of detector and noise-floor setting) to be used during the measurement must be selected in advance with the NF and HV commands, otherwise, the measurements are performed with the detector settings at the time the scan is triggered.
- The ion detector can be zeroed, prior to the measurements, performing an analog or histogram scan or using the CA command, under the same detector settings. (An offset-correction factor is calculated and stored in memory that it is then automatically used by the Miniscan procedure to correct all ion currents measured). The CA command will also update the internal scan parameters to assure that the correct RF levels (i.e. as specified by the last Peak Tuning procedure) are programmed on the RF rods as a function of mass during the Miniscan.

Parameters:

MR0: The RF/DC voltages are completely shut down and no measurement is performed (no ion current is transmitted back to the host computer).

Use this command format at the end of a set of single mass measurements to make sure the RF/DC are completely turned off.

MRparam, param:1 - M_MAX : A Miniscan is performed around the mass number selected by the parameter and the maximum ion current is sent out over RS232.

The upper mass limit depends on the RGA model number: M_MAX=100 for RGA100, 200 for RGA200 and 300 for the RGA300.

Error Checking:

The command does not accept query or default parameters.

Programming tips:

- Single mass measurements are commonly performed in sets where several different masses are monitored sequentially and in a merry-go-round fashion. For best accuracy of results, it is best to perform the consecutive mass measurements in a set with the same type of detector and at the same noise floor (NF) setting. Fixed detector settings eliminate settling time problems in the electrometer and in the CDEM's HV power supply.
- It is good practice to perform an analog scan before triggering a long set of measurements to assure the correct tuning (i.e. correct peak locations and widths) of the quadrupole mass filter. Perform a complete Peak Tuning Procedure as described in the RGA Tuning chapter of this manual if shifts in the peak locations are observed.
- The RF/DC voltages are left on at the end of a single mass measurement. **Use the MR0 command at the end of a set of measurements and before quitting a program to make sure the RF/DC voltages are turned off.**

*SAparam, param: 10 - 25, *, ?*

Description: Steps per amu of analog scan.

Echo: Query Response.

Set the number of steps executed per amu of analog scan. The parameter specifies the number of steps-per-amu.

During an analog scan the quadrupole mass filter is stepped at fixed mass increments through the mass range specified by the MI and MF commands. An ion current is measured after each step and transmitted to the host computer over RS232. SA programs the number of steps executed by the RGA per amu of analog scan. The fixed mass-increment corresponding to each analog scan step is equal to the inverse of the SA parameter value. Since the RGA is usually operated at unit mass resolution throughout its available mass range, the parameter value can also be interpreted as the approximate number of ion currents to be collected for each mass peak in the spectrum.

Parameters:

SAparam, param: 10-25: The parameter specifies the number of steps-per-amu desired during analog scans.

SA*: The number of points per amu value is set to its default value.

Default: 10

SA?: Query. Returns the SA parameter value currently in use by the analog scans.

Error checking:

Number parameters must be integers and within the specified range.

The absence of a parameter (i. e. SA) is treated as an error.

*SC[param], param: 0 - 255, **

Description: Analog Scan Trigger.

Echo: Ion Currents

Execute one or multiple analog scans under the present scan conditions.

The scan parameter can be set for single, multiple and continuous scanning operation.

Analog scanning is the most basic operation of the RGA as a quadrupole mass spectrometer. During analog scanning the quadrupole mass spectrometer is stepped at fixed mass increments through a pre-specified mass-range. The ion current is measured after each mass-increment step and transmitted to the host computer over RS232. The mass range for the scan is set in advance with the commands MI (Initial Mass) and MF (Final Mass) and the mass-increments are fixed with the command SA. Scan rate and detection limits are pre-programmed by the NF (Noise Floor) setting. A current value is transmitted for MI and after each mass increment through MF for a total of $(MF-MI) * SA + 1$ measurements (See AP query command).

The ion currents are represented as integers in units of 0.1 fA, and transmitted directly in Hex format (four byte integers with 2's complement format and Least significant byte first).

The type of detector and noise-floor settings to be used during the scans must be selected in advance with the NF and HV commands.

Important:

- Any command received by the RGA in the middle of a scan will immediately stop the scan, halt transmission and clear the RGA's transmit buffer.
- The detector's zero and the internal scan parameters are checked and corrected at the beginning of each scan resulting in a slight delay before the scan actually starts.

- **A Total Pressure measurement is performed at the end of each scan and transmitted out to the host computer (Please see AP and TP Commands).**
- Unless otherwise specified, the measurements are performed with the detector settings that are present at the time the scan is triggered.

Parameters:

SC: Continuous scanning mode. The RGA produces a continuous string of analog scans.

A new command must be sent to the RGA in order to stop the scanning activity. Once the command is received, the scan is immediately stopped, all transmission is halted and the transmit buffer is flushed (*all remaining data is lost*). The stopping command is executed after the scan is stopped.

SC0: Commonly used to interrupt continuous scanning mode.

SCparam, param: 1 - 255: Multiple scans. The number of scans specified by the parameter is executed. Scanning is immediately stopped when a new command is received as in the case of continuous scanning.

SC*: The default parameter value is used for multiple scan execution.

Default parameter value: 1 (single scan)

Error checking:

Number parameters must be integers and within the specified range.

No query format is allowed for the parameter.

Programming Tips:

- Any command received by the RGA while scanning will immediately stop the scan process and clear the RGA's transmit buffer. Remember to also clear the computer's receive buffer to reset the communications. The new command which stopped the scan will be executed.
- The RGA has the ability to store a complete scan in its output buffer. The scan remains in memory until all the data is transmitted out to the host computer over RS232. As a result of the high acquisition rate of the RGA there might be a delay between the time at which the data is collected and the time at which a complete spectrum is displayed by the host computer. The time lag between data acquisition and display depends on a large number of factors including the scan rate (NF setting) of the RGA, the host computer's processing speed, and the amount of handshaking activity over the RS232 lines.
- Before a new scan starts the RGA checks its internal memory to make sure that no data from any previous scan is pending to be transmitted. If data is still pending, the RGA must finish transmitting it before the new scan can start. This process may result in a delay from the time the scan trigger is

received to the time it actually starts. Using the SC1 command and waiting until the whole scan data stream is transmitted back to the host computer will minimize the problems that are associated to this feature.

- Perform a complete **Peak Tuning** procedure on the RGA ECU if the peaks in the spectrum do not appear at their correct mass values (See Peak Tuning section in the RGA Tuning chapter).

TP?, TP0, TP1

Description: Total Pressure Measurement .

Echo: Measured Ion Current.

Perform a Total Pressure measurement or toggle the TP_Flag on/off.

Total pressure measurements are automatically requested at the end of each analog and histogram scan, and can also be triggered directly by the user with the TP? command. The response of the RGA to a Total Pressure measurement request depends on the status of **TP_Flag** at the time the measurement is requested:

TP_Flag : 1 The measurement is performed and the total ion current is transmitted.

TP_Flag : 0 No actual measurement is performed but a null current is still sent out over RS232.

TP_Flag is set upon a power-on reset and cleared when the CDEM is activated. It can also be toggled on/off by the user with the TP command.

The total ion current measured by the electrometer is transmitted in the standard format : Integer in units of 10^{-16} A, 4 Bytes long, 2's complement format, with the Least significant byte transmitted first.

Notes:

- While performing a total pressure measurement the RF in the quadrupole mass filter is set to 1 amu and the DC bias is zeroed. All ionic species have stable trajectories down the filter under those conditions and reach the ion current detector with different efficiencies.
- TP_Flag is cleared whenever the CDEM is turned on to protect the multiplier from large ion currents. TP1 can be used to reset the flag to one after making sure the total pressure is in a “safe” range for the CDEM.
- The sensitivity of the RGA for total pressure measurements will usually be affected after mass axis recalibrations. Check the sensitivity calibration after any peak tuning procedure.

<p>Important: The sensitivity factor for the TP measurements is highly mass dependent. The additional mass discrimination that takes place in the filter results in the mass dependence of the RGA readings being very</p>

different from that of the Bayard Alpert gauge readings. **Expect to see deviations between the two gauges as the composition of a residual gas changes.**

Parameters:

TP0: TP_Flag is cleared. Total Pressure measurement is disallowed and a null current value is returned as a response to a total Pressure Measurement request (note that this includes the total pressure measurement requests at the end of scans!).

TP1: TP_Flag is set. Total pressure measurement is fully enabled.

TP?: Total Pressure query. A total pressure measurement is triggered and a total ion current value is returned over RS232. The actual response to the command depends on the status of TP_Flag as described above.

Error Checking:

The absence of a parameter is considered an error.

Parameter Storage Commands

MGparam, param: 0.0000 - 2000.0000,?

Description: Electron Multiplier Gain Storage.

Echo: Query Response.

Store a value of electron multiplier (CDEM) Gain, expressed in units of thousands, in the non-volatile memory of the RGA ECU.

The command is typically used together with the MV instruction to store calibrated sets of [High Voltage and gain] for the Electron Multiplier.

Important: The gain is not used internally by the RGA to correct the ion currents measured with the Electron Multiplier, it is simply stored so it can be read and used by any host computer connected to the instrument.

As expected, this command is only available in ECU's with a CDEM option (Opt01) installed (See MO command for details).

Parameters:

MGparam, param: 0.0000-2000.0000: The parameter, interpreted as a CDEM gain in units of thousands, is stored in the non-volatile memory of the ECU.

MG?: Electron Multiplier Gain parameter query.

Error checking:

The absence of a parameter (i. e. MG) is treated as an error.

No default value is available.

A bad-command communications error is reported when this command is invoked in a unit with no CDEM option installed (See MO command).

MVparam, param: 0 - 2490,?

Description: Electron Multiplier Bias Voltage Storage.

Echo: Query Response

Store a value of Electron Multiplier (CDEM) Bias Voltage, in units of Volts, in the non-volatile memory of the RGA ECU.

The command is typically used together with the MG instruction to store calibrated sets of [Bias Voltage and gain] for the Electron Multiplier.

Important: The voltage value is not used internally by the RGA to set the bias voltage of the Electron Multiplier, it is simply stored so it can be read and used by a host computer.

As expected, this command is only available in ECU's with a CDEM option installed (See MO command for details).

Parameters:

MVparam, param: 0-2490: The parameter, interpreted as a CDEM bias voltage in units of Volts, is stored in the non-volatile memory of the ECU.

MV?: CDEM Bias voltage query.

Error checking:

The absence of a parameter (i. e. MV) is treated as an error.

No default value is available.

A bad-command communications error is reported when this command is invoked in a unit with no CDEM option installed.

SPparam, param:0.0000 - 10.0000, ?

Description: Partial Pressure Sensitivity Factor storage and query.

Echo: Query Response

Store a value of Partial Pressure Sensitivity, expressed in units of mA/Torr, in the non-volatile memory of the RGA ECU.

Important: The sensitivity factor is not used internally by the RGA to turn ion currents into partial pressures, it is simply stored in memory so it can be read and used by any host computer connected to the instrument (See HV command.)

Partial Pressure Sensitivity factors are gas specific, probe specific, and highly dependent on the ionizer and quadrupole mass filter conditions and on aging of the probe.

Note: The parameter value loaded at the factory is the partial pressure sensitivity factor for N₂ under default ionizer conditions.

Parameters:

SPparam, param:0.0000 - 10.0000: The parameter, interpreted as a partial pressure sensitivity factor in units of mA/Torr, is stored in non-volatile memory of the ECU. . Typical value is 0.1 under default ionizer settings.

SP?: Partial Pressure Sensitivity factor query.

Error checking:

Parameter must be within specified range.

No default value is available.

STparam, param:0.0000 - 100.0000, ?

Description: Total Pressure Sensitivity Factor storage.

Echo: Query Response

Store a value of Total Pressure Sensitivity, expressed in units of mA/Torr, in the non-volatile memory of the RGA ECU.

Important: The sensitivity factor is not used internally by the RGA to turn ion currents into total pressures, it is simply stored so it can be read and used by any host computer connected to the instrument.

Total Pressure Sensitivity factors are gas specific, probe specific, and highly dependent on the ionizer conditions and on aging of the probe.

Note: The parameter loaded at the factory is the total pressure sensitivity factor for N₂ under default ionizer conditions.

Parameters:

STparam, param:0.0000 - 100.0000: The parameter, interpreted as a total pressure sensitivity factor in units of mA/Torr, is stored in non-volatile memory of the ECU. Typical value is 0.01 under default ionizer settings.

ST?: Total Pressure Sensitivity factor query.

Error Checking:

Parameter must be within specified range.
No default value is available.

Mass Filter Control Commands

MLparam, param: 0.0000 - M_MAX

Description: Mass Lock

Echo: none

Activate the quadrupole mass filter (QMF) and center its pass-band at the mass value specified by the parameter. The QMF is parked at the mass requested but no ion current measurements take place.

The parameter is a real number and the mass increments are limited to a minimum value of 1/256 amu.

The command execution involves two steps:

1. The RF/DC levels corresponding to the mass requested are calculated and set on the QMF rods based on the mass axis calibration parameter values specified by the last Peak Tuning procedure.
2. The firmware stabilizes the voltage output of the RF Driver's controller against temperature fluctuations. The result is very stable RF/DC levels that are highly insensitive to the operating conditions of the RGA ECU.

Important: The RF/DC stabilization algorithm (Step 2 above) remains active as long as no new commands are detected by the RGA ECU. Once a new command is received, stabilization stops, and the new command is executed.

Use the ML0 command to turn off the RF/DC bias when finished performing measurements and before quitting the program controlling the RGA.

Parameters:

ML0.0000: The RF/DC voltages are completely turned off.

MLparam, param: 0.0040 - M_MAX: The parameter represents the mass setting for the QMF in amu units. The minimum mass increment value is 1/256 amu.

The upper mass limit depends on the RGA model number: M_MAX=100 for RGA100, 200 for RGA200 and 300 for RGA300.

Error checking:

Parameters must be numbers within the specified range.

The absence of a parameter (i.e. ML) generates a bad parameter error .

Error Reporting Commands

EC?

Description: RS232_ERR Byte Query

Echo: RS232_ERR Byte.

Query the value of the RS232_ERR byte. The value of the RS232_ERR byte is sent to the computer in ASCII format and with a <LF><CR> terminator. RS232_ERR and bit 0 of STATUS are then cleared to provide a clean error reporting slate.

Important: See “Troubleshooting the RGA Communications” in the RGA Programming chapter for more details on the use of this query.

Parameters: This command is a query, and can only have one parameter format:

EC?

Error checking:

The only acceptable parameter is a question mark.

The absence of a parameter (i. e. EC) is treated as a bad-parameter error.

ED?

Description: DET_ERR Byte Query

Echo: DET_ERR Byte.

Query the value of DET_ERR and update its value after running a fresh check on the Electrometer (Bit5 of STATUS and the DET_ERR byte are updated based on the tests results). The DET_ERR byte value is returned to the computer in ASCII format and with a <LF><CR> terminator. No errors are present as long as the byte value is zero.

Consult the Error Byte Definitions section in this chapter for details on the different error bytes of the RGA.

Consult the RGA Troubleshooting chapter of this manual for possible causes and solutions to any problems reported.

Always try the query a second time before declaring a hardware problem.

Important: The electrometer is not affected by this test, and the detector is restored to its pre-test configuration once the command execution is over.

Parameters: This command is a query, and can only have one parameter format:

ED?

Error checking:

The only acceptable parameter is a question mark.

The absence of a parameter (i. e. ED) is treated as a bad-parameter error.

EF?

Description: FIL_ERR Byte Query

Echo: FIL_ERR Byte.

Query the value of FIL_ERR.

The FIL_ERR byte value is returned to the computer in ASCII format and with a <LF> terminator.

FIL_ERR can only be modified by the “Filament Protection Mode” which constantly monitors the filament while it is emitting electrons. No errors are present as long as the byte value is zero. A non-zero FIL_ERR byte is only cleared after the filament’s heater successfully (i.e. no detected errors) establishes a finite electron emission current.

Consult the Error Byte Definitions section of this chapter for details on the different error bytes of the RGA.

Consult the RGA Troubleshooting chapter of this manual for possible causes and solutions to any problems reported.

Parameters: This command is a query, and can only have one parameter format:

EF?

Error checking:

The only acceptable parameter is a question mark.

The absence of a parameter (i. e. EF) is treated as a bad-parameter error.

EM?

Description: CEM_ERR byte Query

Echo: CEM_ERR Byte.

Query the value of CEM_ERR.

If no electron multiplier (CEM) is available, the absence of the CEM is reported setting bit 7 of CEM_ERR before the byte value is transmitted.

In all cases, the CEM_ERR byte value is sent to the computer in ASCII format with a <LF><CR> terminator. CEM_ERR and Bit 3 of STATUS are then cleared.

This query command can be used to determine whether the CDEM option is installed in the RGA unit being programmed: A CDEM option is available if Bit 7 of CEM_ERR is cleared when the byte is queried (See also MO command).

Parameters: This command is a query, and can only have one parameter format:

EM?

Error checking:

The only acceptable parameter is a question mark.

The absence of a parameter (i. e. EM) is treated as a bad-parameter error.

EP?

Description: PS_ERR Byte Query.

Echo: PS_ERR Byte.

Query the value of PS_ERR and update its value after running a fresh check on the 24V External Power Supply (Bit6 of STATUS and the PS_ERR byte are updated based on the tests results). The PS_ERR byte value is returned to the computer in ASCII format and with a <LF><CR> terminator. No errors are present as long as the byte value is zero.

Consult the Error Byte Definitions section of this chapter for details on the different error bytes of the RGA.

Consult the RGA Troubleshooting chapter of this manual for possible causes and solutions to any problems reported.

Always try the query a second time before declaring a hardware problem.

Parameters: This command is a query, and can only have one parameter format:

EP?

Error checking:

The only acceptable parameter is a question mark.

The absence of a parameter (i. e. EP) is treated as a bad-parameter error.

EQ?

Description: QMF_ERR Byte Query.

Echo: QMF_ERROR Byte.

Query the value of QMF_ERR and update its value after running a fresh check on the Quadrupole Mass Filter's RF Power Supply (Bit4 of STATUS and the QMF_ERR byte are updated based on the tests

results). The QMF_ERR byte value is returned to the computer in ASCII format and with a <LF><CR> terminator. No errors are present as long as the byte value is zero.

Consult the Error Byte Definitions section of this chapter for details on the different error bytes of the RGA.

Consult the RGA Troubleshooting chapter of this manual for possible causes and solutions to any problems reported.

Always try the query a second time before declaring a hardware problem.

Parameters: This command is a query, and can only have one parameter format:

EQ?

Error checking:

The only acceptable parameter is a question mark.

The absence of a parameter (i. e. EQ) is treated as a bad-parameter error.

ER?

Description: STATUS Byte Query.

Echo: STATUS Byte.

Query the value of the STATUS Error byte.

The STATUS byte value is returned to the computer in ASCII format and with a <LF> terminator. No errors are present as long as the byte value is zero.

If one or more bits of the STATUS byte are found set, the specific error bytes (PS_ERR, DET_ERR, QMF_ERR, CEM_ERR, FIL_ERR, and RS232_ERR) must be queried individually to diagnose the problem.

Consult the Error Byte Definitions section of this chapter for details on the different error bytes of the RGA.

Consult the RGA Troubleshooting chapter of this manual for possible causes and solutions to any problems reported.

Important: Since internal checks are constantly being performed within the RGA ECU, the STATUS Byte should be queried regularly by the programming software to detect any possible problems.

Parameters: This command is a query, and can only have one parameter format:

ER?

Error checking:

The only acceptable parameter is a question mark.

The absence of a parameter (i. e. ER) is treated as a bad-parameter error.

Tuning Commands

CE?

Description: Calibration Enable Query.

Echo: JP100 setting.

Query the Calibration Enable/Disable jumper (JP100) status. An internal jumper (JP100) on the digital (i.e. top) electronics board of the RGA's ECU box can be configured by the end-user to enable/disable the modification of the peak tuning parameters. The CE query command returns the JP100 setting in ASCII format with a <LF><CR> terminator. The two options for the query response are:

JP100 jumper is in the Calibration Disabled position. Peak Tuning Parameters protected by the JP100 jumper.

JP100 jumper is in the Calibration Enabled position. Peak Tuning Parameters not protected by the JP100 jumper.

Parameters: Only one possible command format is allowed

CE?

Error Checking:

The only acceptable parameter is a question mark. The absence of a parameter (i. e. EC) is treated as a bad-parameter error.

*DIparam, param: 0 - 255, *, ?*

Description: DI Parameter adjust (Peak Width Tuning command).
JP100 Jumper protected.

Echo: Query Response.

Program the value of DI during the Peak Width Tuning Procedure. The parameter (one of four peak tuning parameters) represents the DI value, in bit units.

Warning: Please read the Peak Tuning Section of the RGA Tuning Chapter before using this command.

The RGA ECU adjusts the DC levels of the quadrupole filter during measurements so that constant mass resolution is automatically available throughout the entire mass range of the spectrometer. The bulk of the DC voltage is supplied by a DC power supply whose output is linearly related to the RF amplitude. The rest of the DC voltage (DC_Tweek) is provided by the output of an 8 bit digital-to-analog converter (DAC). The firmware uses two Peak Tuning Parameters : DI (Intercept) and DS (Slope), stored in the

non-volatile memory of the RGA, to calculate the 8 bit settings of the DAC according to the linear equation:

$$\text{DAC8}(m) = \text{DS} \cdot m + \text{DI}$$

where m is the mass in amu, and $\text{DAC8}(m)$ is the 8 bit setting at that mass.

The purpose of the Peak Width Tuning Procedure is to determine the values of DI and DS so that all the peaks in an analog spectrum have the desired peak width (typically 1 amu).

The DI command is used to program the value of the DI peak tuning parameter during the Peak Width Tuning Procedure. The value is saved in the non-volatile memory of the RGA ECU and used by the firmware to generate $\text{DAC8}(m)$ during measurements.

Note to Supervisors: A calibration disable jumper (JP100) available on the circuit board can be used by a supervisor to block any attempt to modify the value of the DI parameter. Supervisors may use this feature to prevent accidental changes in the calibration parameters by inexperienced operators. Setting JP100 will disable peak tuning of the ECU.

Parameters:

DIparam, param: 0 - 255: If Calibration is enabled by the jumper JP100 (See CE Command) the value of DI in non-volatile memory is updated and the internal scan parameters used to program the DC during scans and single mass measurements are updated accordingly.

DI*: Use this format to replace the peak tuning parameter with the original factory setting for DI. The factory value is retrieved from memory, and used as the new parameter value to execute the command as above

DI?: Query. Returns over RS232 the value of DI currently stored in memory.

Error checking:

The absence of a parameter (i. e. DI) is treated as an error in the parameter. This parameter is protected by an internal jumper (JP100) and a Protection-Violation error will result if the jumper is in the Calibration Disable mode (See CE command).

*DSparam, param: -0.8500 - +0.8500, *, ?*

Description: DS Parameter adjust (Peak Width Tuning command).
JP100 Jumper protected.

Echo: Query Response.

Important:

RGA200 DS range: -1.2750 - +1.2750

RGA100 DS range: -2.5500 - +2.5500

Program the value of DS during the Peak Width Tuning Procedure. The parameter (one of four peak tuning parameters) represents the DS value, in units of bits/amu.

Warning: Please read the Peak Tuning Section of the RGA Tuning Chapter before using this command.

The RGA ECU adjusts the DC levels of the quadrupole filter during measurements so that constant mass resolution is automatically available throughout the entire mass range of the spectrometer. The bulk of the DC voltage is supplied by a DC power supply whose output is linearly related to the RF amplitude. The rest of the DC voltage (DC_Tweek) is provided by the output of an 8 bit digital-to-analog converter (DAC). The firmware uses two Peak Tuning Parameters : DI (Intercept) and DS (Slope), stored in the non-volatile memory of the RGA, to calculate the 8 bit settings of the DAC according to the linear equation:

$$\text{DAC8 (m)} = \text{DS} \cdot \text{m} + \text{DI}$$

where m is the mass in amu, and DAC8(m) is the 8 bit setting at that mass.

The purpose of the Peak Width Tuning Procedure is to determine the values of DI and DS so that all the peaks in an analog spectrum have the desired peak width (typically 1 amu).

The DS command is used to program the value of the DS peak tuning parameter during the Peak Width Tuning Procedure. The value is saved in the non-volatile memory of the RGA ECU and used by the firmware to generate DAC8(m) during measurements.

Note to Supervisors : A calibration disable jumper (JP100) available on the circuit board can be used by a supervisor to block any attempt to modify the value of the DI parameter. Supervisors may use this feature to prevent accidental changes in the calibration parameters by inexperienced operators. Setting JP100 will disable peak tuning of the ECU.

Parameters:

DSparam, param: -0.8500 - +0.8500: If Calibration is enabled by the jumper JP100 (See CE Command) the value of DS in non-volatile memory is updated and the internal scan parameters used to program the DC during scans and single mass measurements are updated accordingly. RGA100 DS range: -2.5500 - +2.5500

DS*: Use this format to replace the peak tuning parameter with the original factory setting for DS. The factory value is retrieved from memory, and used as the new parameter value to execute the command as above.

DS?: Query. Returns over RS232 the parameter value currently saved in memory.

Error checking:

The absence of a parameter (i. e. DS) is treated as an error in the parameter.

This parameter is protected by an internal jumper (JP100) and a Protection-Violation error will result if the jumper is in the Calibration Disabled mode (See CE command).

*RIparam, param: -86.0000 - +86.0000, *, ?, none*

Description: RF_Driver output @ 0 amu (Peak Position Tuning command).
JP100 Jumper protected.

Echo: Query Response.

Warning: Please read the Peak Tuning Section of the RGA Tuning Chapter before using this command.

Program the output of the RF_Driver @ 0 amu during a Peak Position Tuning Procedure. The parameter (one of four peak tuning parameters) represents the voltage output selected for the RF_Driver @ 0 amu, in mV.

The magnitude of the RF determines the mass-to-charge ratio of the ions that can pass through a quadrupole mass filter without striking the rods (i.e. with stable oscillations). A linear relationship between mass and RF amplitude is one of the most attractive features of these type of filters.

The regulated output of the RF source that powers the RGA's quadrupole rods is controlled by, and linearly related to, the voltage output of an RF_Driver circuit. A linear relation exists between the output of the RF_Driver, the RF amplitude on the rods, and the mass setting of the filter. The purpose of a Peak Position Tuning Procedure is to determine the voltages that the RF Driver must output at 0 and 128 amu so that all the peaks in an analog spectrum appear in the right position. The RI command is used to program the voltage output of the RF_Driver @ 0 amu during the Peak Position Tuning Procedure. The value is saved in the non-volatile memory of the RGA ECU and used by the firmware to generate the internal scan parameters used to step the RF during scans and single mass measurements .

Note to Supervisors : A calibration disable jumper (JP100) available on the circuit board can be used by a supervisor to block any attempt to modify the value of the DI parameter. Supervisors may use this feature to prevent accidental changes in the calibration parameters by inexperienced operators. Setting JP100 will disable peak tuning of the ECU.

Parameters :

RIparam, param: -86.0000 - +86.0000: If Calibration is enabled by the JP100 jumper (See CE Command), the parameter is saved into the non-volatile memory of the RGA ECU and the internal scan parameters used to step the RF during scans and single mass measurements are updated accordingly.

RI*: Use this format to replace the peak tuning parameter with the original factory setting for the RF_Driver output @ 0 amu. The factory value is retrieved from memory, and used as the new parameter value to execute the command as above.

RI?: Query. Returns over RS232 the parameter value currently saved in memory.

RI: Uses the current parameter value to recalculate the internal scan parameters used to step the RF during scans and single mass measurements. This is often used to compensate against small temperature drifts in the mass scale, caused by drifts in the output of the RF_Driver.

Error checking:

The absence of a parameter (i. e. RI) is treated as an error in the parameter.

This parameter is protected by an internal calibration jumper (JP100) and a Protection-violation error will result if the jumper is in the Calibration Disabled mode (see CE command).

RSparam, param: 600.0000 - 1600.0000, *, ?, none

Description: RF_Driver output @ 128 amu (Peak Position Tuning command).
JP100 Jumper protected.

Echo: Query Response.

Warning: Please read the Peak Tuning Section of the RGA Tuning Chapter before using this command.

Program the output of the RF_Driver @ 128 amu during a Peak Posion Tuning Procedure. The parameter (one of four peak tuning parameters) represents the voltage output selected for the RF_Driver @ 128 amu, in mV.

The magnitude of the RF determines the mass-to-charge ratio of the ions that can pass through a quadrupole mass filter without striking the rods (i.e with stable oscillations). A linear relationship between mass and RF amplitude is one of the most attractive features of these type of filters.

The regulated output of the RF source that powers the RGA's quadrupole rods is controlled by, and linearly related to, the voltage output of an RF_Driver circuit. Clearly, a linear relation exists between the output of the RF_Driver, the RF amplitude on the rods, and the mass setting of the filter. The purpose of a Peak Position Tuning Procedure is to determine the voltages that the RF Driver must output at 0 and 128 amu so that all the peaks in an analog spectrum appear in the right position. The RS command is used to program the voltage output of the RF_Driver @ 128 amu during the Peak Position Tuning Procedure. The value is saved in the non-volatile memory of the RGA ECU and used by the firmware to generate the internal scan parameters used to step the RF during scans and single mass measurements .

Note to Supervisors: A calibration disable jumper (JP100) available on the circuit board can be used by a supervisor to block any attempt to modify the value of the DI parameter. Supervisors may use this feature to prevent accidental changes in the calibration parameters by inexperienced operators. Setting JP100 will disable peak tuning of the ECU.

Parameters:

RSparam, param: 600.0000 - 1600.0000: If Calibration is enabled by the JP100 jumper (See CE Command), the parameter is saved into the non-volatile memory of the RGA ECU and the internal scan parameters used to step the RF during scans and single mass measurements are updated accordingly.

RS*: Use this format to replace the peak tuning parameter with the original factory setting for the RF_Driver output @ 128 amu. The factory value is retrieved from memory, and used as the new parameter value to execute the command as above.

RS?: Query. Returns over RS232 the parameter value currently saved in memory.

RS: Uses the current parameter value to recalculate the internal scan parameters used to step the RF during scans and single mass measurements. This is often used to compensate against small temperature drifts in the mass scale, caused by drifts in the output of the RF_Driver.

Error checking:

The absence of a parameter (i. e. RS) is treated as an error in the parameter.

This parameter is protected by an internal calibration jumper (JP100) and a Protection-violation error will result if the jumper is in the Calibration Disabled mode (see CE command).

Error Byte Definitions

The **Error Bytes** described in this section store the results of the firmware-driven checks built into the RGA ECU. Use the Error Reporting commands to query the value of the bytes.

Important: No errors are present as long as all bits in the Error Bytes are cleared.

The **RGA Windows** software supports all the Error Reporting commands and reports the errors detected based on their Error Codes.

The RGA Troubleshooting chapter identifies the different problems based on their Error Codes and suggests possible causes and solutions.

STATUS Error Byte: General Status byte. Each bit corresponds to a different type of internal check.

Bit	Internal Check ^(a)	ERROR Byte ^(c)	Query ^(d)
7	not used	N.A.	N.A.
6	24V External P/S ^(b)	PS_ERR	EP?
5	Electrometer ^(b)	DET_ERR	ED?
4	Quadrupole Mass Filter ^(b)	QMF_ERR	EQ?
3	Electron Multiplier	CEM_ERR	EM?
2	not used	N.A.	N.A.
1	Filament	FIL_ERR	EF?
0	Communications	RS232_ERR	EC?

(a) RGA component checked. Each check involves several tests on the component.

(b) Checks automatically performed upon a power-on-reset

(c) Error bytes that store the results of the tests for each type of internal check.

(d) Error Reporting command that queries the error byte.

PS_ERR Error Byte: 24V P/S Error Byte.

Bit	Description	Error Code
7	External 24V P/S error: Voltage >26V.	PS7
6	External 24V P/S error: Voltage <22V.	PS6
5	Not used	
4	Not Used	
3	Not Used	
2	Not Used	
1	Not Used	
0	Not Used	

DET_ERR Error Byte: Electrometer Error Byte.

Bit	Description	Error Code
7	ADC16 Test failure.	DET7
6	DETECT fails to read +5nA input current	DET6
5	DETECT fails to read -5 nA input current	DET5
4	COMPENSATE fails to read +5nA input current	DET4
3	COMPENSATE fails to read -5nA input current	DET3
2	Not Used	
1	OP-AMP Input Offset Voltage out of range	DET1
0	Not Used	

QMF_ERR Error Byte: Quadrupole Mass Filter RF P/S Error Byte.

Bit	Description	Error Code
7	RF_CT exceeds (V_EXT- 2V) at M_MAX	RF7
6	Primary current exceeds 2.0A	RF6
5	Not used	
4	Power supply in current limited mode.	RF4
3	Not Used	
2	Not Used	
1	Not Used	
0	Not Used	

CEM_ERR Error Byte: Electron Multiplier Error Byte.

Bit	Description	Error Code
7	No Electron Multiplier Option installed	EM7.
6	Not Used	
5	Not Used	
4	Not Used	
3	Not Used	
2	Not Used	
1	Not Used	
0	Not Used	

FIL_ERR Error Byte: Filament Error Byte.

Bit	Description	Error Code
7	No filament detected.	FL7
6	Unable to set the requested emission current.	FL6
5	Vacuum Chamber pressure too high.	FL5
4	Not used	
3	Not used	
2	Not used	
1	Not used	
0	Single filament operation.	FL0

RS232_ERR Error Byte: Communications Error Byte

Bit	Description
7	Not used
6	Parameter conflict
5	Jumper protection violation
4	Transmit buffer overwrite
3	OVERWRITE in receiving
2	Command-too-long.
1	Bad Parameter received
0	Bad command received

Chapter 4.

Trouble Shooting

In This Chapter

System Problems	4-2
Diaphragm Pump Does Not Start	4-2
Turbo Pump Does Not Start	4-2
Turbo Pump Does Not Reach Full Speed	4-2
RGA Fails After Capillary Flow Valve Opened	4-2
Loud Noises While Shutting Down	4-3
Nothing Operates	4-3
Internal Error Detection in the SRS RGA	4-4
24V DC Power Supply	4-5
Electrometer	4-5
Quadrupole Mass Filter RF P/S	4-6
Filament's Background Protection mode	4-7
Windows Software Error Codes	4-8
DET1	4-8
DET3	4-8
DET4	4-8
DET5	4-9
DET6	4-9
DET7	4-9
EM7	4-10
FL6	4-10
FL7	4-11
PS6	4-11
PS7	4-12
RF4	4-12
RF6	4-12
RF7	4-13

System Problems

Diaphragm Pump Does Not Start

If the light next to the diaphragm pump switch on the front panel is dim, then the microcontroller is trying to run the pump. A relay click can be heard when the controller attempted to start the pump. If the click was not heard, the microcontroller or relay could have failed. If the click was heard, try venting the system to atmospheric pressure. If the diaphragm pump still does not start, the system requires service.

If the light next to the diaphragm pump switch on the front panel is flashing, the microcontroller is rejecting the request to turn on the pump. This can only happen after a power failure. Turn off all four switches, and wait for the light(s) to stop flashing. Turn back on the diaphragm pump switch and the pump should start.

Turbo Pump Does Not Start

If the light next to the switch on the front panel is dim, then the microcontroller is attempting to start the turbo pump. There is a secondary fuse on the turbo controller board that could have failed. If the sound of the pump starting is absent and the current indicator does not show any power being consumed, the controller has failed.

Turbo Pump Does Not Reach Full Speed

The turbo pump should accelerate to full speed in under two minutes. An excessive gas load can prevent this from happening. If the pump is not reaching full speed, check the current indicator.

- If 3 or 4 bars are lit (0.3 to 0.4 A), the pump is drawing a typical idle current. Under this circumstance, there is no reason the pump should not be at full speed. The stored settings in the memory programming of the turbo pump controller may have become corrupted.
- If all the bars are lit, there is either a leak in the high vacuum area or the foreline pressure is too high. The pressure gauge should prevent the foreline pressure from being too high. If its calibration is incorrect the gauge may be reading a low pressure when the actual pressure is >5 mbar.

RGA Fails After Capillary Flow Valve Opened

When the capillary flow is started a pressure pulse will occur which invariable will shut off the RGA filament. The overpressure protection will shutoff the filament a set an error condition. The RGA Windows software attempts to recover from this gracefully, but sometimes the RGA sets multiple error bits. Use the Head|Reset command to clear the error bits, and turn the filament back on. To avoid this: manually turn off the filament before starting the capillary flow. The overpressure protection is not meant to be frequently used; think of it as a type of software fuse.

Loud Noises While Shutting Down

It is common to hear loud noises while the turbo pump is coasting to a stop. The pump is a vibration source which slowly scans the frequency range from 1250 Hz to 0 Hz. Any resonances in the chassis are momentarily excited as the pump passes through the resonant frequency. These noises are normal and of no concern. Venting the system will cause the turbo pump to quickly decelerate and avoid the noise.

Nothing Operates

If the main power switch does not light, either the main fuse is blown or the light in the switch is burned out. The light in the switch is intended to last forever, so this is not the leading suspect.

If the power switch light is on and the fan is working, then the 24 VDC power supply is operational. If the light is on and the fan is not operating, then the fuse in the 24 VDC power supply could be blown.

Internal Error Detection in the SRS RGA

Several firmware-driven checks automatically test the RGA when the instrument is turned on, and continuously monitor the internal workings of the unit. A “Background Filament Protection Mode” is activated, when the filament is turned on to protect the delicate filament (and CDEM) from accidental overpressures. Several commands can be used to trigger hardware tests on the ECU. Any one of the internal checks just described can detect and report errors, but it is the responsibility of the user to monitor the RGA Head for error reports.

Important: Even though the hardware tests built into the RGA Head can check the instrument for a large variety of problems, they cannot detect all possible error conditions.

Errors in the RGA are detected by querying the Error Bytes with the Error Reporting commands. The “Error Byte Definitions” section of the RGA Programming chapter describes the different error bytes used to store the results of the internal checks. The “Error Reporting Commands” query the error bytes and can be used to quickly diagnose problems.

RGA Windows supports all the Error Reporting commands and constantly monitors the value of the Error Bytes. “Error Report” Windows immediately announce all detected errors and identify the different problems based on unique Error Codes. Refer to the next section of this chapter for Troubleshooting information specific to each Error Code.

Users developing their own RGA control software should integrate the Error Reporting commands into their software, and use them periodically. Consult “Error Checking the RGA”, in the RGA Programming chapter of this manual, for details. Use the Error Byte Definitions listing to obtain the Error Codes for the detected errors.

Error Checking Tips:

- RGA Windows users: Use the Retry button of the Error Report Window to trigger one or two fresh error checks on the hardware, before declaring a problem.
- RGA Programmers: Repeat the query command, if a problem was detected after the last query.
- Note that the values of the Error Bytes often change after an Error Byte query command is executed. Some query commands update the byte value after performing a fresh test on the hardware, while others clear error bits, after they are read, to provide a clean error-reporting slate. Please see the Error Reporting Commands list for details.
- RGA Programmers should consider having their programs automatically report the Error Code for each problem detected.
- Use the Get Head Info... command in the Head Menu of RGA Windows to get a complete listing of all the Error Bytes at any time.

The following sections describe the internal checks, based on the hardware components they test. The information presented includes:

- The type of check performed.
- The bit of Status affected.
- The specific Error Byte affected (See Error Byte Definitions).

- The query command that can be used to trigger the check (see Error Reporting Commands.)
- The prefix of the Error Codes associated to the check.
- Is this check performed at power-on?

24V DC Power Supply

STATUS Bit affected:	6
Error Byte affected:	PS_ERR
Error Reporting Command:	EP?
Error Codes prefix:	PS
Power-on check?:	Yes

The output of the external 24 V DC Power Supply must be between 22 and 26 Volts at all times while the RGA is in operation. Its voltage level is automatically tested when the instrument is turned on and can be checked at any time with the query command: EP?. The same test is performed in units with built-in power modules (Option Opt02) to check the voltage output of the internal switching power supply. If a voltage out of the allowable range is found, the POWER LED is turned off, the red Error LED is turned on, Bit 6 of STATUS is set, and PS_ERR is updated to indicate the specific problem.

Electrometer

STATUS Bit affected:	5
Error Byte affected:	DET_ERR
Error Reporting Command:	ED?
Error Codes prefix:	DET
Power-on check?:	Yes

Ion currents from the Faraday Cup or the electron multiplier are measured with a very sensitive logarithmic electrometer. The voltage levels are digitized with a 16 bit analog-to-digital converter (ADC16) and turned into current values using a digital logarithmic interpolation algorithm that calculate the currents from an internal calibration curve.

The Electrometer/ADC16 system is automatically tested by the firmware on power-on and can be

checked at any time with the query command: ED?.

Several tests are performed during the check:

1. The ADC16 input is grounded and its digital output is measured to make sure it corresponds to less than 15 mV.
2. A current of +5nA is injected into the electrometer and the output is read and compared to expected values.
3. The same test is repeated with -5 nA of input current.

If an error is detected: Bit 5 of STATUS is set, DET_ERR is updated, and the Error LED is turned on. The detector is reconfigured to its pre-check configuration once the tests are over.

Quadrupole Mass Filter RF P/S

STATUS Bit affected:	4
Error Byte affected:	QMF_ERR
Error Reporting Command:	EQ?
Error Codes prefix:	RF
Power-on check?:	Yes

The RF power supply that biases the rods of the Quadrupole Mass Filter is thoroughly checked upon a power-on reset and can be tested at any time using the query command: EQ?.

The RF amplitude is set at the level corresponding to the maximum mass value for the head (100 amu for RGA100, 200 amu for RGA200 and 300 amu for RGA300) and the following tests are done:

- The voltage on the primary of the RF transformer is checked to make sure it is at least 2V lower than the DC voltage used to power the instrument.
- The amount of current flowing through the primary of the transformer is checked to make sure it is less than 2.0 Amps.
- RF_PRI is also checked (against RF_SET) to make sure the driver is not in current limiting mode.

If a problem is detected in any of these checks Bit 4 of STATUS is set, QMF_ERR is updated, and the Error LED is turned on.

Filament's Background Protection mode

STATUS Bit affected:	1
Error Byte affected:	FIL_ERR
Error Reporting Command:	EF?
Error Codes prefix:	FL
Power-on check?:	No

The filament is by far the most carefully protected component of the RGA.

When a electron emission current is requested, the RGA biases the ionizer and activates the filament's heater until the desired electron current is achieved. The Filament LED is turned on to indicate the presence of emission and the filament's "Background Protection Mode" is automatically enabled to continuously (675Hz) monitor the operation of the filament.

The conditions detected during Background Filament Protection are:

- Filament not present (burnt or not installed)
- Unable to set the requested emission current.

If any of these two error conditions is detected while the filament is on, the heater is immediately shut down and the specific problem is reported as follows:

1. Bit 1 of STATUS is set.
2. FIL_ERR is updated
3. Filament LED is turned off.
4. Error LED is turned on.
5. The Leak and Burnt LED's are updated according to the specific problem encountered.
6. The Electron Multiplier is also turned off.

Once detected, a filament error can only be cleared by successfully turning on the filament to a finite electron emission current. It is always good practice trying again, if the first attempt to get emission failed. Please refer to the FL command in the "RGA Command Set" to get more details on the operation of the filament.

Important: Background Filament Protection is also automatically enabled while the ionizer is in the Degas Mode.

Windows Software Error Codes

A unique Error Code has been assigned to each one of the fault conditions that can be internally detected by the RGA Head. The Error Codes are used only by the RGA Windows program to report all internally detected errors. This section lists causes and troubleshooting procedures for all the possible Error Code values available in the SRS RGA.

DET1

- Type of Error:** Electrometer
- Error Message:** Electrometer Error: OP-AMP Input Offset Voltage out of range.
- Error Cause:** A large offset input voltage is present in one or both of the I-V converter op-amps. This problem results in electrometer calibration errors, and will cause erroneous ion current readings.
- Troubleshooting:** Contact SRS.

DET3

- Type of Error:** Electrometer
- Error Message:** Electrometer Error: COMPENSATE fails to read -5nA input current.
- Error Cause:** The logarithmic output of the temperature-compensating picoammeter is not within the levels expected for a -5 nA input current.
- Troubleshooting:** Contact SRS.

DET4

- Type of Error:** Electrometer
- Error Message:** Electrometer Error: COMPENSATE fails to read +5nA input current.
- Error Cause:** The logarithmic output of the temperature-compensating picoammeter is not within the levels expected for a +5 nA input current.

Troubleshooting: Contact SRS.

DET5

Type of Error: Electrometer

Error Message: Electrometer Error: DETECT fails to read -5nA input current.

Error Cause: The logarithmic output of the picoammeter is not within the levels expected for a -5 nA input current.

Troubleshooting: Contact SRS.

DET6

Type of Error: Electrometer

Error Message: Electrometer Error: DETECT fails to read +5nA input current.

Error Cause: The logarithmic output of the picoammeter is not within the levels expected for a +5 nA input current.

Troubleshooting: Contact SRS.

DET7

Type of Error: Electrometer

Error Message: Electrometer Error: ADC16 Test Failure.

Error Cause: The 16 bit analog-to-digital converter used to digitize the logarithmic output of the picoammeter reports an output greater than 15 mV when its input is grounded.

Troubleshooting: Contact SRS.

EM7

- Type of Error:** Electron Multiplier
- Error Message:** Electron Multiplier Error: No Electron Multiplier Option available in this head.
- Error Cause:** A function involving the electron multiplier was invoked in a unit that does not include the CDEM option.
- Troubleshooting:** Do not use any of the CDEM related commands in this unit.
Upgrade the RGA to an Electron Multiplier option (Opt01).

FL6

- Type of Error:** Filament “Background Protection Mode”.
- Error Message:** Filament Error: Unable to set the requested emission current.
- Error Cause:** The filament heater was unable to establish the requested emission current. The most common reason for this problem is a serious leak in the vacuum system. In the event of an overpressure detection, the filament emission and the electron multiplier are immediately turned off, and the Error and Leak LED’s are turned on to indicate the problem.
- Important: The Leak LED will also be turned on if the Thoria coating of the filament is excessively worn down or damaged. However, this is a more rare event due to the long life of the thoriated iridium filaments.
- Troubleshooting:** The following troubleshooting steps are recommended:
Note: Retry turning on the filament after each step.
The RGA Head must be installed in a vacuum system and pumped down to pressures under 10^{-4} Torr for the instrument to operate correctly.
Check the pressure in the vacuum system.
Check for leaks, open valves or large sources of contamination that might be causing severe overpressures.
- If the pressure is OK (i.e. $<10^{-4}$ Torr), check for shorts in the ionizer assembly. Using an ohmmeter check the conductance between the ionizer’s connectors and the vacuum system. (The ionizer feedthrus can be easily identified using the drawings in the RGA Assembly Chapter).

If a short is detected, remove the probe from the vacuum system, inspect the ionizer and fix any shorts. Note: Use the information in the RGA Maintenance chapter to remove the repeller and/or service the ionizer.

If the short is still present after that, remove the RGA Cover Nipple and inspect the rest of the probe for other sources of shorts (i.e. misalignments, loose screws, etc.). If no short is detected, the Thoria coating of the filament might be damaged.

Inspect the filament (best with a magnifying glass) and look for large sections of Thoria coating missing. If a problem is suspected replace the filament using the procedure in the RGA Maintenance chapter. If the filament still does not turn on, contact SRS.

FL7

Type of Error: Filament “Background Protection Mode”.

Error Message: Filament Error: No filament detected.

Error Cause: No filament was detected after an attempt was made to establish emission current in the ionizer. The Error and Burnt LED’s are turned on by this error.

Troubleshooting: A probe must be connected to the ECU.
The probe must have a filament.
The filament must have at least one intact (i.e. conductive) side. Use an ohmmeter to check continuity across the filament (The two filament feedthrus can be easily identified using the drawings in the RGA Assembly Chapter).
The probe must be correctly connected to the ECU. Tighten the locking screws of the box

PS6

Type of Error: 24VDC P/S.

Error Message: External 24V P/S error: voltage <22V.

Error Cause: Voltage output of 24VDC Power Supply is under the acceptable 22-26V DC range. The Power LED is turned off and the Error LED is turned on instead.

Troubleshooting: Check the voltage output of the external power supply with a voltmeter. Adjust the voltage to 24 V in adjustable external supplies or replace the power supply altogether if necessary.
Contact SRS for units with a built-in power supply (Option Opt02).

PS7

Type of Error: 24VDC P/S.

Error Message: External 24V P/S error: Voltage >26V.

Error Cause: Voltage output of 24VDC Power Supply exceeds the acceptable 22-26V DC range. The Power LED is turned off and the Error LED is turned on instead.

Troubleshooting: Check the voltage output of the external power supply with a voltmeter. Adjust the voltage to 24 V in adjustable external supplies or replace the power supply altogether if necessary.

Contact SRS for units with a built-in power supply (Option Opt02).

RF4

Type of Error: Quadrupole Mass Filter RF P/S.

Error Message: RF P/S Error: Power Supply in current limited mode.

Error Cause: The circuit that drives the primary of the RF Transformer is in current limited mode.

Troubleshooting: Check for a short in the quadrupole connections.

RF6

Type of Error: Quadrupole Mass Filter RF P/S.

Error Message: RF P/S Error: Primary Current exceeds 2.0 Amps.

Error Cause: The circuit that drives the primary of the RF Transformer is delivering an unusually large current.

Troubleshooting: Check for a short in the quadrupole connections.

RF7

Type of Error: Quadrupole Mass Filter RF P/S.

Error Message: RF P/S Error. RF_CT exceeds (V_EXT-2V) at M_MAX.
(M_MAX=100 for the RGA100, 200 for RGA200 and 300 for RGA300)

Error Cause: The RF P/S goes out of regulation when the quadrupole mass filter is programmed to M_MAX amu.

Note: When RGA Windows detects an RF7 error, it automatically tests the RGA Head and quickly determines the maximum mass value at which the RGA mass filter can be operated reliably (i.e. without the RF P/S going out of regulation). If the available mass range is smaller than the user's selected scanning range, a warning is immediately displayed on the PC screen. The user can then choose to proceed (i.e. ignore the problem at own risk) or can get information on how to Troubleshoot the problem by pressing the Help button.

This problem should not be ignored since it can be associated to erroneous readings at high masses.

Troubleshooting:

- Are the electronics warmed up?

The RF P/S is optimized at the factory in a *completely* warmed up ECU box. Cold operation reduces the efficiency of the RF P/S and can, in some cases, lead to an RF P/S error. To *completely* warm up the RGA electronics (and match the factory conditions) turn on the filament to the desired emission current and let the electronics warm up for at least 15 minutes. Once the warm-up time has elapsed, try to operate the RGA to see if the problem has disappeared (for example, trigger a scan over a large mass range.) If the problem is still present, warm up the unit further by performing one or more Degas cycles or setting the quadrupole mass filter to ≥ 50 amu for 15 minutes (see Programming the Quadrupole Mass Filter in Chapter 6 of the manual). It is good practice to keep the filament on as long as the RGA is turned on. Operating the filament keeps the electronics and the probe *completely* warmed up and assures reproducible readings at all times. The filament is burn-out resistant and will operate

continuously for a long time.

Note: During the warm-up period, RGA Windows users should see that the mass range over which the RGA can be operated reliably increases with time until it goes beyond the user's requested scan range. No more warnings are posted beyond that point. If no improvement in the mass range is seen as the unit warms up then go on with the troubleshooting procedure.

- Is a probe connected to the ECU box?

The ECU's RF P/S does not operate properly in the absence of a probe.

- Is the probe correctly connected to the ECU box?

Try disconnecting and reconnecting the ECU box to the probe. Securely tighten the thumb screws to make sure good contact is made between the RF P/S and the quadrupole rod pairs.

Chapter 5. Service

The QMS contains no user serviceable parts. The service information in this chapter is intended for the use of Qualified Service Personnel. Read and understand the warnings on the following page. Read the procedures carefully and prepare by having proper tools available.

In This Chapter

Warnings!.....	5-2
Component Notes	5-3
Gas Handling Components	5-3
Turbo Pump	5-3
Diaphragm Pump	5-3
Fittings and Seals	5-4
CDEM Handling and Care	5-5
Handling and mounting.....	5-5
Operating Temperature & Pressure	5-5
Operating Voltage	5-5
Initial pump-down	5-5
Contamination.....	5-5
Storage	5-6
CDEM Pre-conditioning	5-6
Accessing Internal Components	5-7
Opening the Chassis	5-7
Internal View.....	5-8
Removing the RGA ECU.....	5-9
Removing the RGA Probe	5-9
General Checks	5-11
Leak Testing	5-11
Internal Fuses	5-11
Pressure Gauge Recalibration	5-11
Cleaning	5-13
Bake-out.....	5-13
Ionizer Degas	5-14
CDEM Cleaning	5-14
Quadrupole Filter Cleaning	5-15
Component Replacement	5-20
Ionizer Replacement	5-20
Filament Replacement	5-23
CDEM Replacement	5-25
Replacement Parts	5-28
Factory Service.....	5-29
Declaration of Contamination.....	5-29

Warnings!

- **The service information in this chapter is for the use of Qualified Service Personnel. To avoid shock, do not perform any procedures in this chapter unless you are qualified to repair electronic and vacuum equipment.**
- **Read and follow all Warnings before servicing the product.**
- **Dangerous voltages, capable of causing injury or death, are present in this instrument. Use extreme caution whenever servicing any of its parts.**
- **Carefully follow the instructions in this chapter. Failure to do so might result in serious personal injury and damage to the instrument.**
- **Use only SRS supplied replacement parts. Do not substitute parts or modify the instrument. Because of the danger of introducing additional hazards, do not install substitute parts or perform any unauthorized modification to the product. Do not use the product if it has unauthorized modifications. Return the product to SRS for service and repair to ensure that safety features are maintained.**
- **Disconnect the ECU box from the probe before servicing any of the probe components.**
- **Turn off the emission and wait for at least 30 minutes before removing a probe from a vacuum chamber. Serious burns can occur if the probe components are handled too soon.**
- **Use proper vacuum procedures when handling open components and avoid contamination:**
 - **Work in a clean, dust free area. A clean room environment is best.**
 - **Do not talk or breath on any of the parts.**
 - **Wear gloves!**
 - **Use clean tools during service procedures!**
 - **Wear face masks, hair covers and no facial make-up.**
- **Protect the integrity of the vacuum seals:**
 - **Avoid scratching the metal seals.**
 - **Do not exchange nonmetal seals for metal seals.**
- **The fumes from organic solvents such as acetone, methanol and isopropyl alcohol can be dangerous to health if inhaled and are highly flammable. Work in well ventilated areas and away from flames.**
- **Stanford Research Systems does not guarantee that the cleaning procedures described in this chapter will completely remove contamination from the probe. In some cases (*i.e.* depending on the vacuum composition) replacement of the parts might be the only solution to a contamination problem.**

Component Notes

Gas Handling Components

The QMS system is designed to require low maintenance. A regular maintenance schedule will not extend the life of the components. The pumps are intended to be used until they fail. At such time factory service or kits are available. The sections below discuss methods for diagnosing the performance of the major components of the system (the RGA is discussed in its manual).

Turbo Pump

The turbo pump is permanently lubricated. It requires no maintenance for the life of the bearings, which is highly dependent on the gases pumped and the environment the pump is used in. Under normal environments (high vacuum and no corrosive gases) the pump can be expected to work continuously for many years. Under higher gas loads, corrosive environments, or repeated shock forces, the life of the bearings is degraded. Bearings in the pump can be replaced by the factory. An exchange program is available that minimizes down-time by shipping an equivalent rebuilt pump immediately in exchange for the users pump. Contact SRS or your distributor for details.

Diaphragm Pump

Typically, the QMS system operates at high vacuum and places very little load on the diaphragm pump. Lifetimes of over two years are possible under these conditions. Frequent start ups and shut downs increase the load on the pump and decrease the lifetime. Keeping the pump cool will also extend its operating life. Good statistical data is not available for these pumps. You can expect 1 year minimum and 2 years typical.

The performance of the pump can be diagnosed by tracking the ultimate vacuum of the QMS system. To measure the ultimate vacuum place the sealing plug in the inlet Ultra-Torr fitting and open the capillary flow valve. This will connect the diaphragm pump to the pressure gauge. New systems will show less than 0.5 mbar. This measurement can be misleading when significant outgassing loads are present in the internal tubing of the QMS. When making this ultimate vacuum measurement, give the system several hours minimum to reach a steady pressure.

A second method of monitoring the diaphragm pump is to monitor the ultimate vacuum in the high vacuum chamber in the QMS. With both valves closed, measure the spectrum with attention to the nitrogen and oxygen peaks. New systems will show nitrogen at approximately 2×10^{-9} mbar and oxygen at 1/4 that value. These gases are present because air backstreams through the turbo pump. The pressure at the RGA will increase directly with the pressure at the turbo exhaust. Thereby, the ultimate vacuum at the RGA is a direct indication of the vacuum in the backing line and the performance of the diaphragm pump. As an example, a new system will have a backing line pressure of 1 mbar and at ultimate vacuum will have oxygen present at 5×10^{-10} mbar. One year later, another ultimate vacuum test might show oxygen present at 1×10^{-9} mbar. This value indicates that the backing line pressure has

doubled to 2 mbar. The turbo pump can easily tolerate exhaust pressures up to 5 mbar, so the performance of the diaphragm pump is still acceptable in this example.

The pumps contains two components that are most likely to fail: valves and membranes. The valves tend to wear resulting increased backing line pressure (decreased compression ratio). The membranes tend to fail suddenly by tearing and result in the pump being unable to achieve usable vacuums. Kits are available that allow the pump to be serviced by the user or the pump can be returned for service. A kit of replacement seals is available from SRS or the manufacturer.

Fittings and Seals

If the ultimate vacuum of the diaphragm pump appears to be increasing, the first check should be for leaks in the internal plumbing. The metal fittings in the instrument should not fail, but the elastomeric materials may fail over several years. An RGA is an excellent leak tester. The Leak Testing section in this chapter discusses the procedure.

To isolate vibrations, a flexible hose connects the diaphragm pump to the turbo pump. The connections to the ends of the 1/4 inch hose can be quickly remade:

- Twist the aluminum sleeve counter-clockwise to remove it from the hose barb. This may take many turns.
- Push off the flexible hose and replace with a similar length piece.
- A small amount of grease (Apiezon or other hydrocarbon based vacuum grease) can be applied on the hose barb to improve the seal.
- Reattach the sleeve. When remaking the connection, wet the outside of the hose with water to ease installation of the sleeve.

After re-attaching the hose, check to see if the ultimate vacuum has improved. You can check for leaks, but it is rare that the hose barb will leak.

The hose barb at the diaphragm pump has a BSP/ISO 1/8-28 228/1 thread, which uses an elastomer seal retained within a metal ring (Cajon part number S-2-RS-2V). To replace the seal, remove the flexible hose as discussed above. You can just remove one end, or replace the entire hose at the same time. With the hose removed, you can remove the fitting by turning counter clockwise. This fitting is a face type seal and thereby does not rely on the threaded portion of the body to make a seal. Teflon tape is not required nor helpful. The smooth faces on the diaphragm pump and on the body of the hose barb must be clean and free of nicks or scratches. Before replacing the seal, wipe the faces clean with a lint free cloth which has been wetted with a minute amount of grease. Excessive force is not required when tightening the fitting to the body of the pump. The metal ring limits the compression of the elastomer seal to its ideal value. Once metal to metal contact is reached, tighten the fitting only slightly further.

The o-ring sealing the backing line to the turbo pump body is unlikely to leak. In the event it is damaged, replace it with a standard o-ring for a KF16 flange (either Viton[®] or buna-N). Only the elastomer needs to be replaced; the metal centering ring can be reused.

CDEM Handling and Care

Continuous Dynode Electron Multipliers (CDEM) have a history of high performance and dependability in mass spectrometry applications. By following the simple recommendations described below the user should achieve a long useful lifetime from these detectors.

Handling and mounting

- Handling and mounting of the CDEM should only be performed in a clean vacuum fashion.
 - Work on a clean dust-free area. Avoid dust, lint and any kind of particulate matter.
 - Wear powder rubber gloves or finger cots.
 - Use properly degreased tools.
- Avoid excessive shock, such as from dropping onto a hard surface (Remember that CDEM's are made out of glass).

Operating Temperature & Pressure

The recommended operating pressure is 3×10^{-6} or less. The lower the pressure during any operation, the longer the lifetime of the CDEM.

Never apply voltage to a CDEM at pressures above 10^{-4} Torr.

The safe operating temperature of a CDEM is less than 100°C .

The bakeout temperature must be less than 300°C with no voltage applied across the unit.

Operating Voltage

The maximum voltage applied to any CDEM should not exceed 3500V. The SRS RGA High Voltage power supply is limited to a 2500V output. Typical operating range is 1100-2500V. In general, the lower the average signal current drawn from the detector and the lower the operating voltage, the longer the lifetime that will be realized.

Initial pump-down

To best maintain the high gain and low dark current properties of electron multipliers it is very important to follow the steps described in the CDEM Pre-conditioning section of this chapter during the initial pump-down of the electron multiplier. The procedure serves to degas the detector and stabilize the gain. Failure to follow the recommended steps before powering up the multiplier might result in gain degradation by as much as a factor of ten.

Contamination

The active surface of the CDEM can be repeatedly exposed to air without degradation; however, it should not be contaminated with dust, lint or other particles. Organic substances present in the vacuum system tend to accumulate on the active surface of the multiplier and lead to slow performance degradation (due to reduced secondary emission efficiency).

Oil contamination is a serious problem, and can result in catastrophic destruction of the multiplier: use

liquid nitrogen traps with diffusion pumps (particularly for silicone oil based pumps) , and molecular sieves traps with mechanical roughing pumps whenever possible.

If the multiplier becomes contaminated it must be cleaned immediately! (See **CDEM Refreshment** procedure in this chapter)

Storage

CDEM's can be stored indefinitely in a clean dry container such as an air or dry nitrogen-filled "dry box". Double bagging with clean, dust-free zip locked bags also works well as a temporary alternative

CDEM Pre-conditioning

Use the following steps on the first pump-down and initial operation of a new CDEM:

1. Pump overnight prior to initial application of voltage.
2. Begin operation at the lowest voltage possible, working up to the voltage required to produce observable peaks.
3. Limit the initial operation to scanning over small peaks. Only after two hours of operations, should you use the multiplier on larger peaks.

All CDEM's undergo an initial cleanup phase during which absorbed gases are removed from the active surface. If during this time the detector is exposed to high input currents permanent gain degradation by as much as a factor of ten may result. The steps described above help to control initial outgassing and are performed in order to precondition the CDEM. Optimum sensitivity and longer lifetime will result if the recommendations are followed.

Accessing Internal Components

The first step to all of the service procedures in the cleaning or replacement sections is opening the QMS chassis. This involves removing the aesthetic covers. Have the QMS turned off, cooled, and vented to atmospheric pressure before beginning. After that, various components can be worked on as described in later sections. All the sections below describe how to disassemble the system. Unless mentioned otherwise, the steps are reversed for reassembly.

Warning:

Unplug the line cord from the power entry module before performing this procedure

Opening the Chassis

Equipment

- Phillips screwdriver
- 3/16 hex key

Procedure

1. Remove the two socket head screws that attach the handle.
2. Remove the screws around the perimeter of the painted metal cover: 4 on back, and 6 on bottom. Slide the cover back about 1/4 inch. Pull the bottom edges of the cover away from the chassis until the hooks on the front edge clear the chassis. Lift the entire cover off.
3. Remove the 7 screws around the perimeter of the plastic bezel (one is on the bottom) and pull the bezel off the front a small distance and stop. Remove the ribbon cable from the front display panel (note the Pin 1 marking). Lay the bezel down in front of the system. The power switch wires do not need to be removed.
4. At this point, lay the instrument on its left side.
5. The right side of the chassis is covered with a flat panel. Remove the screws around the perimeter: 3 each on top, right, and bottom and 2 on the front. The second screw on the front is less obvious. Lift up the lexan overlay to expose an access hole. The side cover can now be removed. With this cover removed, the chassis is far less rigid.

Internal View

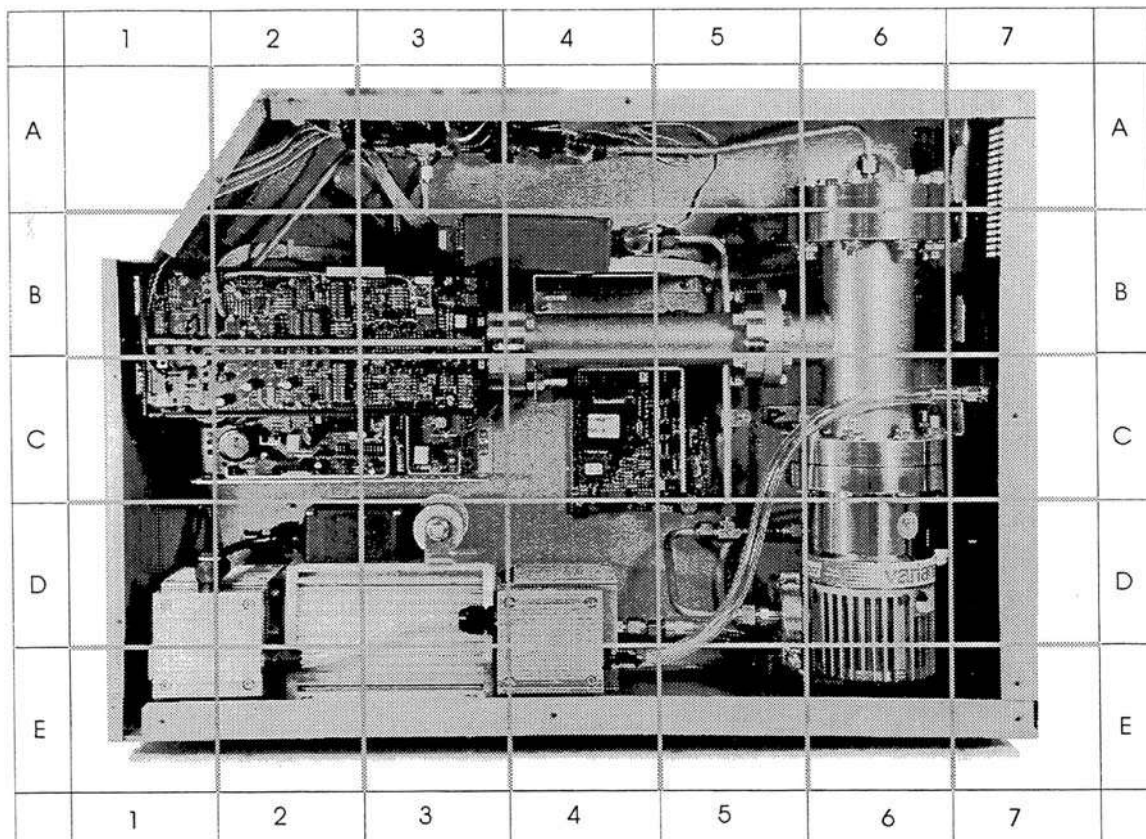

Map of Internal Components

Removing the RGA ECU

The RGA ECU is supported between the front panel and the probe body. After following the “Opening the Chassis” section above, this procedure can be performed. Reverse the procedure to reattach the ECU.

Equipment

- Phillips screwdriver
- 5/16 socket driver and ratchet wrench

Procedure

1. Remove the wires from the power switch. These connectors are very secure and require much force to remove (as they should). Use needle nose pliers and grab the crimped portion of the connector to remove it. Do not pull by the wires.
2. The small plate with lexan that is attached to the front panel is held with one screw on the left hidden under the lexan and the screws on each side of the inlet fitting. Remove these screws and the nut on the Ultra-Torr fitting. The small plate will now slide off.
3. The main front panel is held by one remaining screws on the front and two nuts on the inside top flange. The two nuts require the socket wrench for easy removal. Pull the front panel off a set aside.
4. The RGA ECU is now exposed. Remove the orange power connector from the top circuit board. Remove the RS232 cable, which is held with two screws. Turn the two large knobs which secure the ECU to the probe counter clockwise until the ECU can pull free from the probe.

Removing the RGA Probe

To access the filament, and electron multiplier, the RGA probe needs to be removed from the 1.5 inch flange attached to the large vacuum chamber.

Note

You will need a new copper gasket for a 2 3/4 inch CF flange to reassemble the RGA probe. Do not be tempted to reuse the old copper gasket. Make sure you have another gasket before performing a filament or electron multiplier replacement. The less time the RGA probe is left exposed to air, the cleaner it will stay.

Handling Notes

- Up to this point, the QMS has remained gas tight. At this stage the vacuum seals will be broken. These steps should only be performed in a clean vacuum fashion.

- Work in a clean dust-free area. Avoid dust, lint and any kind of particulate matter.
- Wear talc-free rubber gloves or finger cots.
- Use properly degreased tools.
- Avoid excessive shock, such as from dropping onto a hard surface (Remember that the CDEM is made out of glass).

Equipment

- 1 or 2 copper gaskets for 2 3/4 CF flange
- 1/4 inch 12 point box wrench
- two 7/16 inch open end wrenches

Procedure

1. Remove the two nuts on the long bolts that extend through the support bracket. On the left side panel remove the four screws that hold the L bracket that is supporting the feedthrough end of the RGA probe. If the chassis is laying on its side, tip it up to remove the four screws and lay back down when done.
2. At the flange connecting the RGA to the large chamber, loosen each of the six bolts a small amount at a time. Once the nuts turn freely, remove the nuts, but leave the bolts extending through the flanges. These are the only parts holding that end of the flange.
3. While supporting the flange remove each bolt. When the last bolt is removed, slide the entire probe straight towards the front of the box. The ionizer of the RGA will be exposed. Move the probe and bracket to a clean surface. Cover the exposed end of the probe with clean, lint free clothes or foil.
4. Remove the bracket by sliding off the long bolts and pulling.

General Checks

Leak Testing

The seals in the system will have a long life. The metal seals will last indefinitely under normal usage. Only severe force or corrosion will cause them to fail. Elastomeric seals can eventually degrade. The integrity of these seals can be assured using the leak testing mode of the RGA software. Helium or other gases can be used, *e.g.* argon, or tetrafluoroethane. The CF flanges and VCR fittings have leak testing ports. Spray the test gas directly into these ports and look for any increase in the level measured by the RGA. Leaks should be immediately detected in this manner.

The valve seat seals in the solenoid valves can also be tested with the RGA. Close both valves and fill the inlet tube with the test gas. Injecting the test gas through a 1/16 inch flexible tube that has been fed into the inlet connection several inches will allow the inlet area to be well flushed. Leaks across the seats will take some time to be detected. Keep the inlet flushed with test gas for several minutes.

The backing line can be visually inspected or more rigorously tested with helium. If helium leaks into the backing line, it can backstream through the turbo pump to the RGA and be detected. Setup the leak testing mode to detect helium and spray the hose fittings well. Smaller leaks can be detected by placing a bag over the fittings to produce a pure helium atmosphere around the suspect leak. This process is not as fast as with the metal seals. It can take several minutes for the helium to be detected.

Internal Fuses

Three components inside the QMS contain fuses. These are second tier protection and are never expected to fail. If the main fuse has blown replacing it does not restore the system, it is possible that one of the internal fuses has also blown. One fuse is located on the 24 V power supply (A3 in the internal view). The RGA ECU has a fuse on the top board, directly behind the 9 pin connector. These first two can be visually inspected. The turbo pump controller has a fuse in a vertical holder on the top right corner. A screwdriver is required to remove the fuse for inspection.

Pressure Gauge Recalibration

The pressure gauge is intended only as a rough indicator of system performance. The gauge itself is precise, the display on the front panel has just been simplified. With a voltmeter with standard 1/8 inch test probes, the setpoint and calibration of the gauge can be checked. The gauge contains a relay setpoint, which is used by the QMS microcontroller to assure the correct operation of the system. If the pressure gauge becomes severely mis-set or calibrated, it could interfere with the operation of the instrument. A mis-calibrated gauge could also lead one to believe that the diaphragm pump performance was failing when it was actually operating correctly. The easiest way to check the gauge is

to install a second gauge in the inlet fitting of the QMS. The two gauges are then compared to see if the internal gauge is correct.

Note that the gauge is a thermocouple type gauge and its sensitivity will vary significantly with the composition of the gas being measured. It is calibrated for air or nitrogen. Its sensitivity deviates significantly for helium, hydrogen, krypton, and some Freons. If the QMS operates with high concentrations of these gases, the deviation can be enough to prevent the instrument from operating. In such situations, you can recalibrate for the gas the system will operate on or compensate the setpoint.

Recalibration is performed at two points: vacuum and atmospheric pressure.

Vacuum Adjust

The vacuum adjustment can only be performed by pumping the gauge to a pressure less than 10^{-4} mbar. This requires another vacuum pump be connected to the inlet. Place the voltmeter probes into the Analog Monitor and Ground test points. The analog output should read 0.375 V.

Atmosphere Adjust

With both valves closed, remove the capillary or plug from the inlet. This exposes the pressure gauge to atmospheric pressure. Place the voltmeter probes into the Analog Monitor and Ground test points. The analog output should read the following values depending on atmospheric pressure.

altitude (feet above sea level)	pressure (Torr)	analog output (V)
0	760	5.534
1000	733	5.513
2000	707	5.493
3000	681	5.473
4000	656	5.454
5000	632	5.435
6000	609	5.417
7000	586	5.399
8000	564	5.382
9000	543	5.366
10,000	523	5.350

Setpoint

The setpoint is adjusted at the factory to 3.9 V, which corresponds to 10 mbar. This value should not change unless the gauge is damaged. To check the value measure the voltage across the test points on the gauge. To compensate for gas mixtures, the setpoint can be moved to a higher voltage up to 5 to 6 V. This will allow the QMS to operate, but prevents some of the safeguards from working when the sample gas is a normal gas. Contact SRS for assistance in changes to the setpoint.

Cleaning

The most general method of cleaning the QMS is to use the vacuum pumps to remove contaminants. The inlet section is cleaned by installing a plug in the Ultra-Torr fitting and opening both valves. This will cause the pumps to continually draw on these surfaces. In severe contamination cases, more aggressive steps may be required.

Bake-out

Periodic high temperature bakeout can be used to clean the interior surfaces of the QMS system. This is a difficult process and is only recommended in the following cases:

- When background contamination is present in the mass spectra.
- When the performance of the RGA is degraded due to excessive contamination.

As the RGA is used, deposits form on the ionizer parts and on the filter components. The performance of the spectrometer is affected by the build-up of electrostatic charge on the contaminated surfaces. The symptoms of the problem are: decreased sensitivity, decreased resolution and, in severe cases, unusual peak shapes.

Several components limit the highest temperature that can be safely used.

- The valves contains a Viton[®] seal and are rated to 120 °C at the valve body.
- The pressure gauge can only tolerate 85°C.
- The flange of the turbo pump cannot exceed 120 °C. The bearings cannot exceed 60 °C.
- The RGA cannot exceed 100 °C while operating or 250 °C if the ECU is removed.

Given these, a safe strategy is to bake the entire system at less than 80°C. If heating tape is used, wrap the system, stopping at the turbo pump flange and about 1 inch before the RGA ECU flange. For more aggressive bake-outs, careful control of temperature is required. A multipoint thermocouple monitor (e.g. the SR630) or temperature controllers will be necessary.

Warnings:

- **To avoid fire risk use a good quality heater with a built-in temperature limit switch.**
- **To avoid overheating the components use a reliable temperature controller to regulate the bakeout temperature.**
- **Do not leave the system unattended for long periods of time.**
- **To avoid damage to the electronic components detach the ECU from the probe during bakeout.**
- **Do not operate the RGA during bakeouts.**
- **To avoid burns cover the heater with heavy insulation during bakeout, and do not touch the probe until it cools down after bakeout is over.**

Procedure

1. Turn off the RGA and disconnect the ECU from the probe.

2. Wrap a heating tape or heating jacket around the vacuum chamber. Make sure the entire probe, including flanges, is evenly covered.
3. Start the pumps and have both pumps operating. The inlet should be plugged with and both valves open.
4. Bake the system for several hours. Monitor the bakeout to make sure the turbo pump stays cool.
5. After bakeout wait for the probe to cool down to room temperature before mounting the ECU back on its flange.
6. Run the peak tuning procedure.

Ionizer Degas

An Ionizer Degas program is built into the RGA head to clean up the filament and the ionizer by electron impact desorption. Degassing provides a fast way to clean up the ion source, however, it compromises the lifetime of the thoria coating of the filaments and it is no substitute for a complete bakeout of the probe. In the QMS, this procedure is much easier; disassembly of the instrument is not required. Its use is only recommended when contamination of the probe is suspected and a long bakeout is not a practical option.

During the degas process the anode grid and the filament are bombarded by a 20 mA current of 400eV electrons. The complete process takes three minutes and can be triggered directly from the RGA Windows software (Head Menu). The emission current is ramped slowly during the first minute to eliminate sudden bursts of gases into the vacuum system.

The electron multiplier is turned off at the beginning of the cycle. The emission current is turned back to its pre-degas setting at the end of the degas cycle, but the electron multiplier is always left off for additional protection. Overpressure protection is built into the degas procedure and the filament will immediately shut down if a leak is detected.

For users developing their own software, the Degas process can be triggered with the DG command described in the **RGA Command Set List**, and Degas times as large as 20 minutes long can be selected.

CDEM Cleaning

The performance of a CDEM contaminated with organic impurities can sometimes be restored following the cleaning procedure described in this section. The CDEM should show a gain improvement after the cleaning.

Warning

Stanford Research Systems does not guarantee that this procedure will remove contamination from a detector. Use this method as a last resort only.

Warning:

The fumes from isopropyl alcohol can be dangerous to health if inhaled and are highly flammable. Work in well ventilated areas and away from flames.

Warning:

Read and follow all directions and warnings of the ultrasonic cleaner regarding the use of organic solvents for cleaning.

Equipment

- Ultrasonic cleaner
- Isopropyl alcohol, electronic grade or better.
- 1000 ml beaker
- Oil-free, dry nitrogen
- Petri dish.
- Clean oven (higher than 100°C setting).

Procedure

1. Fill the 1000mL beaker with isopropyl alcohol.
2. Gently place the CDEM into the alcohol.
3. Insert the beaker containing the CDEM into the ultrasonic cleaner for 10 minutes
4. Remove the CDEM from the isopropyl alcohol and allow it to drain for a few minutes
5. Depending on the contamination level, repeat steps 1-4 as needed.
6. Blow dry the CDEM with oil-free dry nitrogen.
7. Place the CDEM in a clean Petri dish and dry at 100°C for about one hour.

Quadrupole Filter Cleaning

The quadrupole mass filter is the heart of the RGA. The sensitivity and resolution of the instrument are ultimately limited by the quality of the quadrupole field between its rods. Deposits on the rods accumulate electrostatic charge and distort the field, resulting in degraded performance. The deposits typically form at the entrance to the mass filter, when the RGA is operated at high pressures or over long periods of time. They are often seen as a discoloration of the metal but in some cases (i.e. depending on the vacuum composition) they are invisible.

If contamination of the rods is suspected, the first step to take is a one- or two-day long bakeout. If bakeout is not successful, the quadrupole filter will need to be cleaned. Note that in order to clean the rods, the entire quadrupole head assembly must be taken apart, and unless the exact nature of the deposits is known, the only sure way to remove them will be with a very fine abrasive.

Warnings:

- **The exact alignment of the rods in the quadrupole is essential to the optimum performance of the RGA.**
- **Do not scratch the surface of the rods.**
- **Do not remove excessive amounts of surface material with the abrasives.**
- **Use clean tools and procedures.**
- **The fumes from acetone and methanol can be dangerous to health if inhaled and are highly flammable. Work in well ventilated areas and away from flames.**

Equipment

- Clean, dust-free work area.
- Latex gloves/powder free.
- One standard OFHC copper gasket for 2 3/4" CF Flange. New and Clean!
- Replacement bowed e-clips (SRS Part# 0-00579-000, 12 count)
- Phillips head screw driver: P1 head (clean.)
- Precision flat-head screw driver: 2.5mm head (clean.)
- Needle nose pliers.
- Micro-Mesh abrasive sheets: 3200 to 12000 grit.
- Ultrasonic cleaner.
- "Mr. Clean" detergent.
- Acetone, Electronic grade or better.
- Methanol, Electronic grade or better.
- 1000 ml beaker.
- Oil-free, dry nitrogen.
- Distilled or de-ionized water.
- Petri dish.
- Clean oven (higher than 100°C setting).

Procedure

1. **Read all warnings** at the beginning of this chapter before attempting to service the probe.
2. Set up in advance a clean dust-free working area where to carry out this procedure.
3. Turn off the RGA and disconnect the ECU from the probe.
4. Wait for the probe to cool down for at least 30 minutes after the emission is turned off. **Severe burns can result if the probe is handled too soon.**
5. Without disconnecting the cover nipple from the vacuum port, remove the six bolts from the feedthru flange at the end of the probe and carefully slide the entire probe assembly out of the vacuum system. The ionizer, the filter, and the detector are now fully exposed and easily accessible.

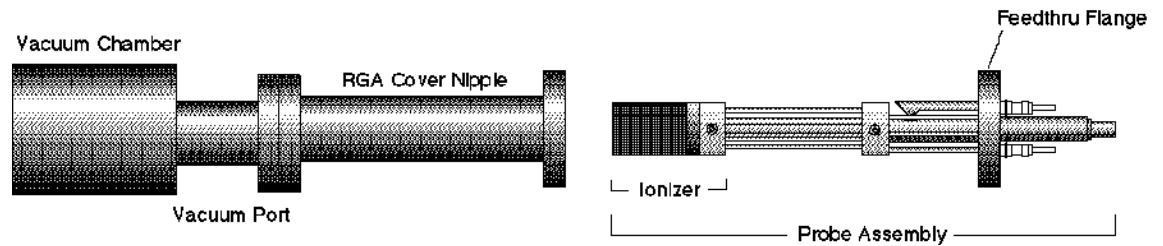

Figure 1 Probe Removal for Quadrupole Filter Cleaning

6. Carry the probe to a clean, dust free area immediately. **Avoid contamination** using handling procedures compatible with high vacuum requirements.
7. Hold the probe in a secure upright position and do a thorough visual inspection of the unit. Check for loose, damaged, misaligned and severely contaminated components. If excessive contamination is evident take the necessary steps to identify and eliminate the contamination sources in the vacuum system. Carefully inspect the ionizer and, if any problems are detected, replace the filament and/or the ionizer as part of this maintenance procedure. Inspect the CDEM for signs of arcing and contamination. If necessary replace the CDEM as part of this maintenance procedure.
8. **Head disassembly:** Only a rough outline of the complete disassembly of the probe is presented here. Use the **RGA Assembly Drawing** of Chapter 9 as a visual aid during the process.
9. *Note the placement of all parts and their orientation before disassembly!*
10. Begin by removing the filament following the necessary steps from the “Filament Replacement” procedure described in this chapter. Be very careful not to damage the thoria coating if you intend to use the same filament during reassembly. Next, remove the CDEM following steps from the “CDEM Replacement” procedure. Store the multiplier in a dry box or desiccator. Loosen the seven screws that fasten the 1/8” diameter rods to the feedthru connectors, and remove the bowed e-clip from the exit plate align rod that is located right above the CDEM. You can now separate the entire quadrupole assembly from the detector/feedthru assembly. There are no serviceable parts in the flange. Set it apart in a safe, clean area. Next, separate the ionizer from the quadrupole filter by removing the e-clips that hold the 1/8” diameter rods in place. Store the ionizer electrodes in a safe clean area. Disassemble the quadrupole and set apart the precision ground rods for cleaning.
11. **Note:** This is a good time to carefully inspect all the components of the probe for damage and contamination. Replace or clean any parts that are suspect.
12. **Warning:** We do not suggest cleaning the alumina spacers but, if signs of severe contamination are evident, a quick ultrasound cleaning with acetone, followed by a 2 hour bakeout at 100-150°C is recommended.
13. **Rods cleaning:** Use the Micro-Mesh abrasives to clean the rods. Begin by using the finest abrasive which will remove the residue, normally 3200 grit. Then consecutively use the next finer

grit down to 12000 until the metal surface has a fine polished appearance. **Warning:** Do not remove excessive material from the surface of the precision-ground rods.

14. After all metal surfaces have been polished, they must be cleaned to remove all the abrasive compound from their surface. Begin by placing the rods in a beaker with a 1:4 solution of “Mr. Clean” detergent in water. (Note: if Mr Clean is not available, use a good quality cleaning compound that leaves no residue after rinsing) Place the beaker in the ultrasound cleaner and agitate for 30 minutes. Decant off the cleaning solution, and repeat the above agitation with 4 to 5 consecutive washes with distilled water to remove the cleaning solvent. Decant off all the water from the parts, and rinse all parts with acetone and then with Methanol (Use the ultrasonic cleaner for best results). Following the rinses, blow dry the rods with filtered dry nitrogen and then bake them out in an oven at 150°C for one hour. **Warning:** After the parts have been cleaned and baked out, they should only be handled wearing powder-free gloves.

15. **Head Reassembly:** Only a rough outline of the complete reassembly of the probe is presented here. Use the **RGA Assembly Drawing** of Chapter 9 and your own notes as a visual aid during this process.

Begin by assembling the quadrupole mass filter. Loosely attach the cleaned rods to the alumina spacers with the spring-loaded, perforated screws. Tighten the screws following the **systematic procedure** described next. Work on one spacer at a time, using a single, small turn of the screwdriver on each screw. After a single round of eight screws, hold a spacer in each hand, and slightly torque the assembly back and forth about its axis to make sure the rods are comfortably seated on their positioning slots. Repeat this tightening procedure, one spacer at a time, constantly checking the alignment, until the spring washers are completely compressed. Once the quadrupole assembly is completed, mount the focus plate and the anode grid on it. Use new e-clips to hold the two ionizer plates against the top alumina spacer, but do not install any e-clips on the bottom grooves of the connection rods at this time. Next, mount the quadrupole assembly on the exit plate of the feedthru flange and secure it in place tightening the two connector screws and inserting an e-clip in the exit plate align rod groove. Insert the rest of the rods in their correct locations and, while checking for the correct alignment of their grooves and slots, tighten the rest of the feedthru connector screws. Once the rods are in place, attach the two RF ribbon connectors to complete the quadrupole filter assembly.

If the RGA probe has a CDEM, mount the multiplier at this time. Adjust the HV connect rod as needed, and tighten all the necessary screws (The threaded hole on the side slot of the rod lines up with the CDEM Clamp hole, and the top groove should be correctly lined up with the edge of the alumina spacer’s alignment hole.)

Install new bowed e-clips in all the grooves located above the alignment holes of the bottom alumina spacer. The clips hold the filter tightly against the exit plate. Finally, install the filament and the repeller cage.

16. Visually inspect the probe to make sure all the parts are in place and correctly aligned. Use an ohmmeter to make sure the electrodes are electrically isolated from each other and from the body of the flange (ground).
17. Once satisfied, install the probe back in the vacuum system and perform a complete "Probe Bakeout" before using the RGA for measurements.
18. Perform a peak tuning procedure on the unit.

Component Replacement

Ionizer Replacement

As the RGA is used, deposits form on the ionizer parts and the sensitivity of the sensor is degraded. Once the sensitivity of the spectrometer is significantly affected by this buildup it is necessary to completely replace the ionizer. All components of the ionizer should be replaced together at once. The replacement procedure is simple and should only take a few minutes.

It is recommended that the filament be replaced as well during this procedure since some damage to its Thoria coating is inevitable during handling.

Equipment

- Ionizer Replacement kit (O100RI): consisting of repeller cage, anode grid, focus plate, and spare screws and e-clips.
- One standard OFHC copper gasket for 2 3/4" CF Flange. New and Clean!
- Precision flat-head screw driver: 2.5mm head.
- Needle nose pliers.
- Latex gloves/powder free.
- Clean, dust-free work area.

Procedure

1. **Read all warnings** at the beginning of this chapter before attempting to service the probe.
2. Set up in advance a clean dust-free working area where to carry out this procedure.
3. Turn off the RGA and disconnect the ECU from the probe.
4. Wait for the probe to cool down for at least 30 minutes after the emission is turned off. **Severe burns can result if the probe is handled too soon.**
5. Without disconnecting the RGA Cover Nipple from the vacuum port, remove the six bolts from the feedthru flange at the end of the probe and slide the entire probe assembly out of the vacuum system (Note the rotational orientation of the Feedthru Flange before removing the probe assembly from the vacuum system so that the probe can be reassembled in the exact same way at the end of the procedure. Mark the side of the flanges with a permanent marker if necessary.) The ionizer, the filter, and the detector are now fully exposed and easily accessible.

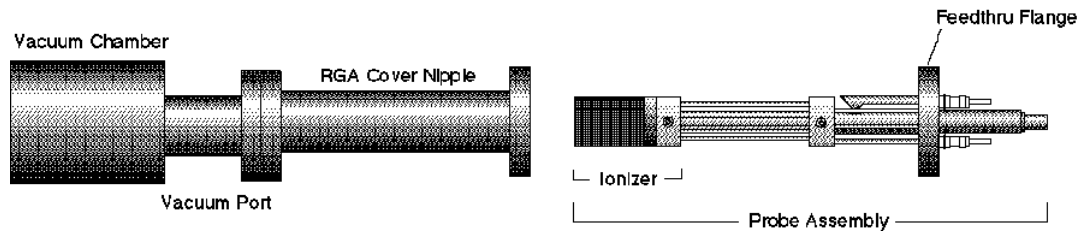

Figure 2 Probe Removal for Ionizer Replacement

6. Carry the probe to a clean, dust free area immediately. **Avoid contamination** using handling procedures compatible with high vacuum requirements.
7. Hold the probe in a upright position and do a thorough visual inspection of the unit. Check for loose, damaged, misaligned and contaminated components.
8. Using the clean, flat-head screwdriver remove the screw that connects the repeller to the longest filament rod and pull out the cage exposing the filament and the anode grid. Be careful not to damage the delicate filament if you plan to use it again!
9. Remove the filament following the steps and precautions described in the “Filament Replacement” section of this chapter.
10. Next, pull out the anode grid after removing the two screws that fasten its bottom plate to the alignment rods. The two rods do not need to be replaced and should not be moved during this procedure!
11. Finally, remove the two screws that hold the focus plate against the top alumina spacer and pull out the plate. The short alignment rod will also need to be removed during this step, but it does not need to be replaced (Save it!).
12. Use the new parts from the “Ionizer Replacement Kit” to replace the ionizer components. The new components are clean and vacuum compatible. **Avoid contamination! Replace all components at once! Discard the old ones!**
13. Use two fresh screws from the ionizer replacement kit to mount the new focus plate on the alumina spacer. Make sure the short alignment rod is put back in place and the screws are tight.
14. Install the new anode grid. Use the new screws to fasten its bottom plate to the alignment rods. **Caution:** The anode cage is fairly strong but it should still be handled very carefully since its correct alignment is essential for optimum performance of the RGA.
15. Once the anode grid is secured in place, replace the filament following the steps described in the “Filament Replacement” section of this chapter. **It is highly recommended that a new filament be used for this step since damage to the delicate thoria coating is unavoidable during removal.**

16. Attach the new repeller to the longer filament rod using a fresh screw. Align the cage and tighten the screw (Correct alignment is best assured when the two small holes on the side of the repeller cage line up with the filament screws.)
17. Inspect visually the entire ionizer assembly to assure the correct alignment of its parts, and, if satisfied, mount the probe back on the vacuum system. Check the correct rotational orientation of the feedtrhu flange (i.e. same as it was before disassembly) before tightening the flange bolts.
18. A bakeout of the probe is highly recommended before operating the RGA again.
19. Retune the sensitivity of the RGA, following the instructions in the RGA Tuning chapter, before using the unit for quantitative measurements.

Filament Replacement

The filament eventually wears out and needs to be replaced. The replacement procedure is simple and can be completed in a few minutes by qualified personnel.

The filament is very delicate and should be handled with extreme care. The thoria coating is very delicate and can easily be damaged if the filament is mishandled. Please read the following handling recommendations before opening the filament's box:

Handling Notes

- Do not bend, or twist the filament.
- Do not scratch the filament's Thoria coating.
- Do not handle the filament directly with your fingers, use fine tweezers, and hold it by the platinum tabs only.
- Do not attempt to clean the filament.
- Use only SRS provided filaments as replacement.

Equipment

- Filament Replacement kit: consisting of new filament, and spare screws and nuts.
- One standard OFHC copper gasket for 2 3/4" CF Flange. New and Clean!
- Precision flat-head screw driver: 2.5mm head.
- Needle nose pliers.
- Latex gloves/powder free.
- Clean, dust-free work area.

Procedure

1. **Read all warnings** at the beginning of this chapter before attempting to service the probe.
2. Set up in advance a clean, dust-free working area where to carry out this procedure.
3. Turn off the RGA and disconnect the ECU from the probe.
4. Wait for the probe to cool down for at least 30 minutes after the emission is turned off. **Severe burns can result if the probe is handled too soon.**
5. Unscrew the six bolts from the RGA's mounting flange and remove the entire probe from the vacuum system (Note the rotational orientation of the RGA Mounting Flange before removing the probe from the vacuum system so that it can be placed in the exact same orientation at the end of the procedure. Mark the side of the flanges with a permanent marker if necessary.). The ionizer is now fully exposed and easily accessible.

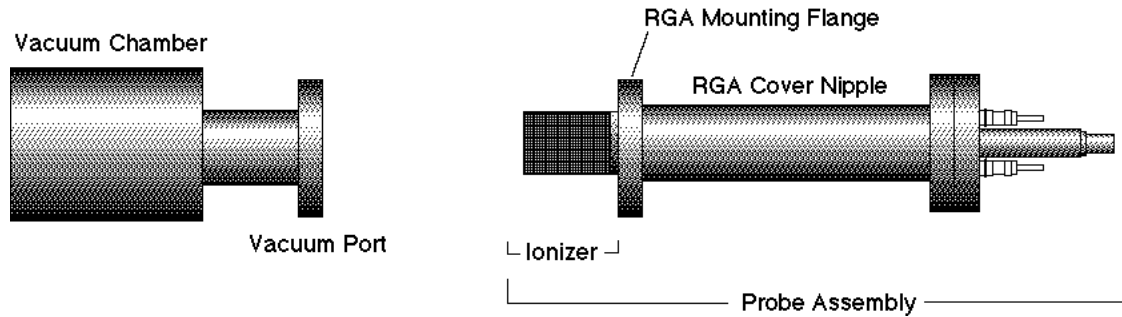

Figure 3 Probe Removal for Filament Replacement

6. Immediately carry the probe to a clean, dust-free area and secure it in an upright position. **Avoid contamination** using handling procedures compatible with high vacuum requirements.
7. Using the clean, flat-head screwdriver remove the single screw that connects the repeller to the longer filament rod and pull out the cage exposing the filament and the anode grid.
8. Before replacing the filament, visually inspect the entire ionizer. Check for loose, damaged, misaligned and contaminated components. Some discoloration of the ionizer parts is common, but heavy buildup on the grids and plates is a sign of severe contamination. If problems are detected, a complete “Ionizer Replacement” procedure should be carried out at this time. Otherwise, continue with the filament replacement procedure.
9. Inspect the filament, and become acquainted with the way in which it is mounted on the filament rods: The SRS RGA filament is of a circular shape and made out of very thin, thoria-coated iridium wire. Two platinum tabs, spot-welded at opposite ends of its circumference, provide electrical connection to the rods that deliver the power during emission. Precision machined slots define the exact placement of the filament tabs along the two rods and a small “screw and nut” set secure each tab in place.
10. Without removing the nuts, loosen the two screws that hold the filament in place enough to pull the filament out the ionizer assembly. Discard the old filament.
11. Leave enough clearance between each nut and the top of its corresponding alignment slot to slide the platinum tabs of the new filament during installation.
12. Open the filament box and pick up the filament by one of its platinum tabs with the clean tweezers.
13. Very carefully slide the filament into position, until the platinum tabs fall into the slots. **Do not bend or twist the filament. Do not scratch the Thoria coating!**
14. Tighten the screws while pressing the nuts against the rods with the tweezers, making sure the tabs are centered in the slots.
15. Visually inspect the filament alignment and do any adjustments that might be necessary. The filament should form a circle around the anode grid. Slight bends in the filament are common, and do not compromise its performance. Severe bends might result in electrical-shorts to the

repeller and anode grid and need to be corrected. Use gentle pressure on the filament wire to bend it back into its correct shape if needed (Note: use a clean cotton swab for this procedure).

16. Attach the repeller to the longer filament rod using a fresh screw. Align the cage and tighten the screw (Correct alignment is best assured when the two small holes on the side of the repeller cage line up with the filament screws.)
17. Inspect visually the entire ionizer assembly to assure its correct alignment, and, if satisfied, mount the probe back on the vacuum system. Check the correct rotational orientation of the probe (i.e. same as it was before disassembly) before tightening the flange bolts.
18. A bakeout of the probe is recommended before operating the RGA again.

CDEM Replacement

The replacement procedure is very simple and can be completed in a few minutes by qualified personnel.

Gain degradation limits the **lifetime** of all electron multipliers. Eventually the gain drops to unacceptable values and the multiplier needs to be replaced. As a rule of thumb, **the CDEM should be replaced when the required gains can no longer be achieved by increasing the bias voltage.**

Warnings:

The CDEM is very delicate and should be handled with extreme care.

Handling Notes

- Handling and mounting of the CDEM should only be performed in a clean vacuum fashion:
- Work on a clean dust-free area. Avoid dust, lint and any kind of particulate matter.
- Wear talc-free rubber gloves or finger cots.
- Use properly degreased tools.
- Avoid excessive shock, such as from dropping onto a hard surface (Remember that the CDEM is made out of glass).
- Use only SRS supplied electron multipliers for replacement.

Equipment

- Multiplier Replacement kit: consisting of new CDEM with mounting clamp in place and spare screws and nuts.
- One standard OFHC copper gasket for 2 3/4" CF Flange. New and Clean!
- Precision flat-head screw driver: 2.5 mm head.
- Needle nose pliers.
- Latex gloves/powder free.
- Clean, dust-free work area.

Procedure

1. **Read all warnings** at the beginning of this chapter before attempting to service the probe.

2. Set up in advance a clean dust-free working area where to carry out this procedure.
3. Turn off the RGA and disconnect the ECU from the probe.
4. Wait for the probe to cool down for at least 30 minutes after the emission is turned off. **Severe burns can result if the probe is handled too soon.**
5. Without disconnecting the cover nipple from the vacuum port, remove the six bolts from the feedthru flange at the end of the probe and slide the entire probe assembly out of the vacuum system (Note the rotational orientation of the Feedthru Flange before removing the probe assembly from the vacuum system so that the probe can be reassembled in the exact same way at the end of the replacement procedure. Mark the side of the flanges with a permanent marker if necessary.) The ionizer, the filter, and the detector are now fully exposed and easily accessible.

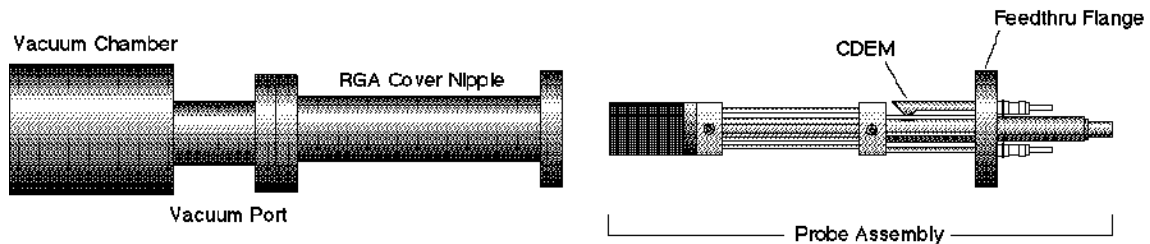

Figure 4 Probe Removal for CDEM Replacement

6. Carry the probe to a clean, dust free area immediately. **Avoid contamination** using handling procedures compatible with high vacuum/clean room requirements.
7. Hold the probe in a secure upright position and do a thorough visual inspection of the unit. Check for loose, damaged, misaligned and severely contaminated components. Carefully inspect the ionizer and, if any problems are detected, perform a filament and/or ionizer replacement following the procedures described earlier in this chapter. Inspect the CDEM for signs of arcing and contamination. A blue tinge is an indication of an electrical arc while brown indicates contamination. A “burned” black color may indicate both arcing and contamination have occurred. If excessive contamination is evident take the necessary steps to identify and reduce contamination sources in the vacuum system.
8. **CDEM Removal:**

Note the position of all parts and their orientation before disassembly!

The CDEM consists of a straight, four-channel tube made out of glass, with a cone of the same material attached to the front end. It is held upright, next to the FC, and away from the axis of the analyzer, by a **clamp** and a **clip**. The **clamp** wraps around the multiplier tube, and is connected to a neighboring rod. It assures proper alignment of the cone and provides the electrical connection to the High Voltage power supply. A hole on the side of the FC Shield allows space for mounting the cone very close to the FC top. The **clip** is spot welded to the side of the FC shield and holds the lower end of the multiplier’s tube at ground. Chrome electrical coatings, deposited at both ends of the multiplier provide the necessary electrical

contacts. A plate (**CDEM Anode**) mounted at the exit of the CDEM collects the secondary electrons. The whole assembly is self aligning.

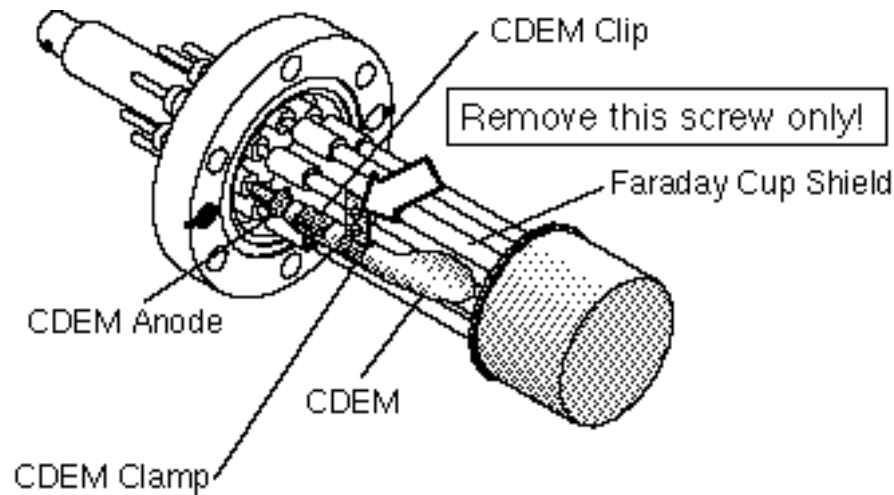

Figure 5 CDEM Replacement

9. Using the clean flat head screwdriver, remove the small screw that fastens the clamp to the HV rod and rotate the entire multiplier about its axis until the clamp's end points away from the FC Shield.
10. Holding on to the clamp's end, pull the multiplier out of the clip.
11. Unpack the new multiplier. Notice that the multiplier has a mounting clamp already in place so there is no need to keep the old one. Avoid contamination.
12. Install the new multiplier in place reversing the removal steps. Clip it in place, rotate it about its axis so the clamp fits into the slot in the HV rod, and fasten the clamp with a small screw.
13. Visually inspect the assembly and do any adjustments that might be necessary. The CDEM should be standing straight up, centered between its two neighboring rods, and with its cone facing straight into the FC shield's hole. The CDEM anode should be $\approx 1\text{mm}$ away from the multiplier's exit, and it can easily be pushed up or down with pliers for correct placement. There should be no electrical contact between the cone (HV) and any part of the probe. If necessary loosen the clamp's screws to do adjustments.
14. Once satisfied with the alignment, mount the probe back on the vacuum system and pump it down. Check the correct rotational orientation of the feedthru flange (i.e. same as it was before disassembly) before tightening the flange bolts.
15. Perform the **CDEM Preconditioning** steps described in this chapter before using the multiplier for actual measurements.
16. Calibrate the gain of the new electron multiplier before using the device for quantitative measurements. See instructions in RGA Tuning chapter.

Replacement Parts

Some of the parts discussed in the previous sections are widely available. For users who wish to obtain replacement parts directly, the following manufacturers part numbers will be needed. Nupro and Cajon parts are carried by your local Swagelok distributor.

diaphragm pump

diaphragm rebuild kit - contact SRS

VCR gaskets

1/4 stainless steel w/ silver coating - Cajon SS-4-VCR-2

RS gaskets

BSP/ISO parallel thread, 1/8-28 - Cajon S-2-RS-2V

Hose

Tygon or similar, 1/4 inch ID × 7/16 inch OD

CF flange copper gaskets,

2 3/4 inch G-275 and 4 1/2 inch G-450

replacement nuts and bolts, 12 point wrenches (1/4 × 5/16) ,

Duniway Stockroom, Mountain View, CA 800-446-8811

Factory Service

The procedures described in this chapter are designed to guide the user through the various steps needed to maintain and/or repair the different components of the QMS instrument. These procedures should only be carried out by qualified personnel who fully understand the instrument. Users who do not feel comfortable or simply do not have the time to go through the different maintenance steps can choose to send the unit back to the factory for out-of-warranty service. Please contact SRS to obtain information.

Important: All users returning a QMS back to the factory for repair and/or service must submit a correctly completed “Declaration of Contamination of Vacuum Equipment ” form along with the instrument. The SRS personnel carrying out the repair and service of vacuum equipment must be informed of the condition of the components before any work is done on the parts. A copy of the form is provided on the next page of this manual.

Appendix A. System Electronics

In This Chapter

Description of Schematics	A-2
Schematic: MCA_C1	A-2
Schematic: MCA_C2	A-3
Schematic: MCA_D1	A-3
Parts List	A-4

Description of Schematics

Control of the system originates from the microcontroller board mounted to the inside top of the chassis. This board controls the pumps, valves, and pressure gauge. The board consists of two parts: the main board and the display board. The main board contains four additional standoff in the center of the board. They thermally connect the board to the chassis and provide additional heat sinking for the voltage regulators and solenoid drives.

The two boards are connected with a ribbon cable that allows for easy removal of the front bezel. For the OEM block option, the connector to the front panel is replaced with an adapter to a 25 pin D connector. This option allows the system to be controlled by a remote computer or user electronics.

The wiring diagram, PCB diagram, and schematics are attached in Appendix C.

Schematic: MCA_C1

Regulated power at 5 and 15 V is derived from the 24 V supply. The 15 V power is used to operate the pressure gauge and the bar graph drive logic. The 5 V power supplies the mcu, and display LED's.

The system is controlled by U1, an MC68HC705K1 microcontroller. This chip is an 8-bit mcu, with 512 bytes of ROM, and 32 bytes of RAM. The 4 MHz crystal is the source of the mcu's 2MHz internal clock. This mcu has 10 bits of I/O (Port A 0-7 and Port B 0-1). The mcu has built in power up delays. The reset and interrupt are not used.

Four of the bits are used as inputs from the front panel switches. Software is used to debounce the switch contacts. A timer interrupt continuously polls the state of the switches. The switch must read the same value twice in succession before it is considered on.

Four of the bits drive a serial shift register, U2, (74HC595) which provides eight bits of output. The gate of U2 is used to prevent the outputs of U2 from appearing in a random state at power up. While the mcu is starting, all the I/O bits are inputs. The pull-up resistor (R3) will de-assert the gate and cause the outputs of U2 to be hi-Z. Resistors assert the default state of the driven components (turbo pump, relay, and solenoids). With this implementation, the pumps and valves will not momentarily turn on during power up.

The remaining two bits are inputs from the turbo pump and pressure gauge. Both provide logic 1 values when the turbo pump is at speed or the pressure is below the setpoint.

This main board routes signals from the turbo pump (current monitor and fault indicator) to the front panel. The pressure gauge is supplied with power. The analog output from the gauge is routed to the front panel display board.

Schematic: MCA_C2

The relay and two solenoid valves have 24 VDC coils. The relay draws very little power and uses a simple drive circuit. Comparator U3A buffers the value from 5 V logic to 0-24 V. The pull-down resistor assures that the relay will be off during power up. The regulator, U6, drives the relay. In this application, it is used as a transistor with the added benefit of over-current limits and thermal protection.

The solenoid valves consume significant power. The circuits shown apply full voltage (24-dropout) to open the valves, but then drop the voltage to a holding value (<4V). Three components (R7,R8,C10) form a high pass filter and a divider. The diode (D2) clamps the adjust pin of the regulator. This clamp protects the device when the valves are turned off. While the solenoids require full voltage to open, they require very little voltage to hold. The minimum output voltage of the regulators is insufficient to disengage the valve. The pair of diodes add a voltage drop that allows the valves to shut off. With this circuit, heating of the valves is reduced to less than 1/4 of what would occur if the full 24 VDC was constantly applied to the coils.

Schematic: MCA_D1

In addition to the discrete LED's, the display board contains the drive logic for the bar graph displays. The LM3914 chip contains logic, comparators, and current regulation for the bar graph LED's. The external resistors trim the setpoints and determine the LED current.

Parts List

Microcontroller Board and Chassis Assembly Parts List

<u>REF.</u>	<u>SRS part#</u>	<u>VALUE</u>	<u>DESCRIPTION</u>
C 1	5-00011-501	27P	Capacitor, Ceramic Disc, 50V, 10%, SL
C 2	5-00011-501	27P	Capacitor, Ceramic Disc, 50V, 10%, SL
C 3	5-00225-548	.1U AXIAL	Capacitor, Ceramic, 50V,+80/-20% Z5U AX
C 4	5-00225-548	.1U AXIAL	Capacitor, Ceramic, 50V,+80/-20% Z5U AX
C 5	5-00100-517	2.2U	Capacitor, Tantalum, 35V, 20%, Rad
C 6	5-00100-517	2.2U	Capacitor, Tantalum, 35V, 20%, Rad
C 7	5-00100-517	2.2U	Capacitor, Tantalum, 35V, 20%, Rad
C 8	5-00100-517	2.2U	Capacitor, Tantalum, 35V, 20%, Rad
C 9	5-00100-517	2.2U	Capacitor, Tantalum, 35V, 20%, Rad
C 10	5-00192-542	22U MIN	Cap, Mini Electrolytic, 50V, 20% Radial
C 11	5-00192-542	22U MIN	Cap, Mini Electrolytic, 50V, 20% Radial
C 12	5-00100-517	2.2U	Capacitor, Tantalum, 35V, 20%, Rad
C 13	5-00102-517	4.7U	Capacitor, Tantalum, 35V, 20%, Rad
D 1	3-00003-301	1N4007	Diode
D 2	3-00004-301	1N4148	Diode
D 3	3-00003-301	1N4007	Diode
D 4	3-00003-301	1N4007	Diode
D 5	3-00003-301	1N4007	Diode
D 6	3-00004-301	1N4148	Diode
D 7	3-00010-303	GREEN	LED, T1 Package
D 8	3-00010-303	GREEN	LED, T1 Package
D 9	3-00010-303	GREEN	LED, T1 Package
D 10	3-00010-303	GREEN	LED, T1 Package
D 11	3-00011-303	RED	LED, T1 Package
HT1	0-00447-007	TO-220	Heat Sinks
J 1	1-00251-130	10 PIN DIL	Connector, Male
J 2	1-00037-130	16 PIN DIL	Connector, Male
J 3	1-00065-114	7 PIN; WHITE	Header, Amp, MTA-100
J 4	1-00250-116	2 PIN, WHITE	Header, Amp, MTA-156
J 5	1-00250-116	2 PIN, WHITE	Header, Amp, MTA-156
J 6	1-00250-116	2 PIN, WHITE	Header, Amp, MTA-156

J 7	1-00250-116	2 PIN, WHITE	Header, Amp, MTA-156
J 8	1-00037-130	16 PIN DIL	Connector, Male
PC1	7-00748-701	QMS CONTROLLER	Printed Circuit Board
R 1	4-00088-401	51K	Resistor, Carbon Film, 1/4W, 5%
R 2	4-00088-401	51K	Resistor, Carbon Film, 1/4W, 5%
R 3	4-00088-401	51K	Resistor, Carbon Film, 1/4W, 5%
R 4	4-00088-401	51K	Resistor, Carbon Film, 1/4W, 5%
R 5	4-00088-401	51K	Resistor, Carbon Film, 1/4W, 5%
R 6	4-00088-401	51K	Resistor, Carbon Film, 1/4W, 5%
R 7	4-00088-401	51K	Resistor, Carbon Film, 1/4W, 5%
R 8	4-00070-401	30K	Resistor, Carbon Film, 1/4W, 5%
R 9	4-00088-401	51K	Resistor, Carbon Film, 1/4W, 5%
R 10	4-00070-401	30K	Resistor, Carbon Film, 1/4W, 5%
R 11	4-00088-401	51K	Resistor, Carbon Film, 1/4W, 5%
R 12	4-00057-401	220	Resistor, Carbon Film, 1/4W, 5%
R 13	4-00761-407	287	Resistor, Metal Film, 1/8W, 1%, 50PPM
R 14	4-00057-401	220	Resistor, Carbon Film, 1/4W, 5%
R 15	4-00057-401	220	Resistor, Carbon Film, 1/4W, 5%
R 16	4-00057-401	220	Resistor, Carbon Film, 1/4W, 5%
R 17	4-00325-407	845	Resistor, Metal Film, 1/8W, 1%, 50PPM
R 18	4-00087-401	510	Resistor, Carbon Film, 1/4W, 5%
R 19	4-00055-401	20K	Resistor, Carbon Film, 1/4W, 5%
R 20	4-00159-407	2.10K	Resistor, Metal Film, 1/8W, 1%, 50PPM
R 21	4-00325-407	845	Resistor, Metal Film, 1/8W, 1%, 50PPM
R 22	4-00186-407	4.22K	Resistor, Metal Film, 1/8W, 1%, 50PPM
R 23	4-00185-407	4.02K	Resistor, Metal Film, 1/8W, 1%, 50PPM
SO1	1-00022-150	16 PIN 300 MIL	Socket, THRU-HOLE
U 1	3-00771-340	68HC705K1	Integrated Circuit (Thru-hole Pkg)
U 2	3-00265-340	74HC595	Integrated Circuit (Thru-hole Pkg)
U 3	3-00098-340	LM324	Integrated Circuit (Thru-hole Pkg)
U 4	3-00114-329	7815	Voltage Reg., TO-220 (TAB) Package
U 5	3-00112-329	7805	Voltage Reg., TO-220 (TAB) Package
U 6	3-00149-329	LM317T	Voltage Reg., TO-220 (TAB) Package
U 7	3-00149-329	LM317T	Voltage Reg., TO-220 (TAB) Package
U 8	3-00149-329	LM317T	Voltage Reg., TO-220 (TAB) Package
U 9	3-00546-340	HDSP-4830	Integrated Circuit (Thru-hole Pkg)
U 10	3-00103-340	LM3914	Integrated Circuit (Thru-hole Pkg)

U 11	3-00546-340	HDSP-4830	Integrated Circuit (Thru-hole Pkg)
U 12	3-00546-340	HDSP-4830	Integrated Circuit (Thru-hole Pkg)
U 13	3-00103-340	LM3914	Integrated Circuit (Thru-hole Pkg)
U 14	3-00103-340	LM3914	Integrated Circuit (Thru-hole Pkg)
Y1	6-00010-620	4.000 MHZ	Crystal
Z0	0-00043-011	4-40 KEP	Nut, Kep
Z0	0-00084-032	36154	Termination
Z0	0-00141-032	2-520194-2	Termination
Z0	0-00187-021	4-40X1/4PP	Screw, Panhead Phillips
Z0	0-00228-052	17" #22 GREEN	Wire #22 UL1007
Z0	0-00231-043	#4 SHOULDER	Washer, nylon
Z0	0-00243-003	TO-220	Insulators
Z0	0-00267-052	6-1/2" #22 RED	Wire #22 UL1007
Z0	0-00268-052	6-1/2" #22 BL	Wire #22 UL1007
Z0	0-00269-052	7-3/4" #22 WH	Wire #22 UL1007
Z0	0-00270-052	7-3/4" #22 BLUE	Wire #22 UL1007
Z0	0-00325-032	2-520182-2	Termination
Z0	0-00436-052	6-1/2" #22 WH	Wire #22 UL1007
Z0	0-00437-052	6-1/2" #22 GR	Wire #22 UL1007
Z0	0-00466-050	23" #18 BLACK	Wire #18 UL1007 Stripped 3/8x3/8 No Tin
Z0	0-00467-050	23" #18 RED	Wire #18 UL1007 Stripped 3/8x3/8 No Tin
Z0	0-00523-048	5-5/8" #18	Wire, #18 UL1015 Strip 3/8 x 3/8 No Tin
Z0	0-00536-032	31894	Termination
Z0	0-00594-050	4-1/2" #18 BLUE	Wire #18 UL1007 Stripped 3/8x3/8 No Tin
Z0	0-00595-050	4-1/2" #18 ORAN	Wire #18 UL1007 Stripped 3/8x3/8 No Tin
Z0	0-00620-056	SOUND/CONTROL	Cable, Coax & Misc.
Z0	0-00621-000	WFB1224HE	Hardware, Misc.
Z0	0-00622-002	PS000S000	Power_Entry Hardware
Z0	0-00627-056	SOUND/AUDIO 1PR	Cable, Coax & Misc.
Z0	0-00633-056	SVT-3 COND	Cable, Coax & Misc.
Z0	0-00634-032	2-520184-2	Termination
Z0	0-00635-032	39-00-0041 MALE	Termination
Z0	0-00636-032	39-00-0047 FEM	Termination
Z0	0-00652-032	328281	Termination
Z0	1-00066-112	7 PIN; 24AWG/WH	Connector, Amp, MTA-100
Z0	1-00254-113	2 PIN, 22AWG/RD	Connector, Amp, MTA-156
Z0	1-00275-131	2 PIN DIF #18GA	Connector, Female

Z0	1-00316-113	8 PIN, 18AWG/OR	Connector, Amp, MTA-156
Z0	1-00317-179	2 PIN PLUG	Connector Housing, Receptacle
Z0	1-00318-179	2 PIN RECPTCL	Connector Housing, Receptacle
Z0	2-00044-211	1901.1102	Switch, Rocker
Z0	7-00731-720	PRS-7	Fabricated Part
Z0	7-00766-709	PRS-9	Lexan Overlay
Z0	9-00267-917	GENERIC	Product Labels

Appendix B

RGA Circuit Description

This chapter describes the electronics circuits located inside the Electronics Control Unit of the RGA. There are no electronic components inside the RGA Probe.

The information in this chapter is provided for the use by qualified technical personnel during service and repairs.

- **Warnings**
The ECU is to be serviced by qualified technical personnel only. There are no user serviceable parts inside.
- **Dangerous voltages, capable of causing injury or death, are present in this instrument. Use extreme caution whenever the ECU covers are removed.**

In This Chapter

Overview of the RGA	B-3
Circuit Description	B-4
General Description	B-4
Circuit Boards.....	B-5
Description of Schematics	B-6
Schematic name: QMSE_T1.....	B-6
Microprocessor	B-6
Digital I/O Ports	B-6
The LED port.....	B-7
The MPX port	B-7
The MISC port	B-8
Clocks.....	B-8
RS232 Interface.....	B-9
Schematic name: QMSE_T2.....	B-9
I/V calibration.....	B-9
A/D Conversion	B-9
Power-up Conditioning	B-10
Schematic name: QMSE_T3.....	B-10
DC Control Voltages	B-10
RF Amplitude Detection.....	B-11
RF Amplitude Control.....	B-11
Foldback Current Limiting.....	B-11
Schematic name: QMSE_B1.....	B-12
Mass filter RF Supply	B-12
DC Potentials	B-13
Schematic name: QMSE_B2.....	B-13
Filament Heater Supply	B-13
Bias Regulators	B-14
Schematic name: QMSE_B3.....	B-15
Power Supplies	B-15

	Schematic name: QMSE_V1	B-15
	Signal Conditioning	B-15
	Schematic name: QMSE_V2	B-17
	Electron Multiplier High Voltage Power Supply	B-17
	Parts Lists	B-18
18	Top Board Components Parts List	B-
22	Bottom Board Parts List	B-
	Vertical Board Parts List	B-29

Overview of the RGA

The SRS RGA is a mass spectrometer consisting of a quadrupole probe, and an Electronics Control Unit (ECU) which mounts directly on the probe's flange.

The quadrupole probe is a mass spectrometer sensor consisting of an ion source, a quadrupole mass filter, a Faraday cup and an optional electron multiplier. Ions are created from the residual gas of a vacuum system by electron impact ionization. Ions of a particular mass-to-charge ratio have stable trajectories through the mass filter, depending on the DC and RF voltages applied to the quadrupole rods. The selected ions are collected in a Faraday cup or multiplied in an electron multiplier.

The ECU box (3" x 4" x 9") contains all the electronics necessary to operate the RGA. It connects directly to the probe's feedthru flange, and also to a host computer. Its regulated power supplies set the ionizer voltages, the filament's electron emission current, the high voltage across the electron multiplier and the RF/DC levels on the quadrupole filter. A logarithmic transconductance amplifier converts ion currents into voltages that are read by an A/D converter. A microprocessor and control firmware direct the operations of the spectrometer, the data acquisition, and the communications through the RS232 serial link.

The electronics operate from a single 24 +/-2 V DC power supply. The peak current requirement is about 2A.

Circuit Description

General Description

The specifications and features of the many circuits that drive the RGA are determined by characteristics of the quadrupole mass spectrometer such as:

- the ionizer settings available to the user,
- the characteristics of the quadrupole mass filter,
- the magnitude of the ion current levels detected during measurements,
- an optional electron multiplier.

The ionizer consists of a dual thoriated iridium filament heated by a current of about 3A at 1.7V. The filament and the associated repeller shield are held at a negative potential between -13 and -97V, determined by the electron and ion energy settings ($V_{\text{repeller}} = \text{ion energy} - \text{electron energy}$). Electrons from the filament are accelerated toward the anode grid cage, which is held at a positive potential of +8 (low) or +12V (high). The 25-105 eV electrons ionize residual gas molecules in the grid cage. The ions are then injected into the mass filter, aided by the focus plate, which is held at a negative potential of about -90VDC (adjustable from 0 to -150V) to optimize the throughput of the mass filter and to deflect electrons.

The mass filter requires two potentials be applied to two pairs of rods. The potentials are given by: $V_{x/y}(t) = \pm [U + V_0 \cos(\omega t)]$, where U is a DC potential amplitude and V_0 is an RF potential amplitude. The physics of the quadrupole mass filter show that the resolution of the instrument improves with the frequency $\omega = 2\pi f$ (the ions interact with the RF field for more cycles), however the required RF amplitude increases with the square of the frequency. An operating frequency $f = 2.7648$ MHz requires an RF amplitude, V_0 , of 1284 V (2568 Vpp) to measure ions with mass of 300 amu (8.56Vpp/amu.). The ratio of DC to RF amplitude, U/V_0 , controls the fractional mass resolution, $M/\Delta M$. For $f = 2.7648$ MHz, the DC potential, U, will +215VDC on one rod pair, and -215 VDC on the other, for masses of 300 amu.

The rod structures are primarily capacitive, so to reduce the circuit drive requirements, the rod reactance is resonated with an inductance. The advantages of this resonant drive circuit is the primary reason for operation at a fixed frequency.

Ions with the selected mass are collected in a Faraday cup. The ion currents can be very low, a few femtoamps, and have a very large dynamic range, up to about 100 nA. A log I/V converter capable of simultaneously measuring ion signals over several orders of magnitude is a natural choice. Low Pass filtering of the signal is essential in the presence of the large rod potentials.

To improve the detection limit, by overcoming the noise floor imposed by the I/V converter, an electron

multiplier may be used. The electron multiplier needs to be biased with as much as -2500VDC to provide gains as large as 10^7 .

Circuit Boards

There are two main PCBs inside the ECU package.

The top PCB has the CPU, RS232, digital ports, the analog electronics for A/Ds and D/As, and the RF amplitude detection circuit. A small vertical PCB which holds the log I/V converter connects to the top PCB. A second small vertical PCB holds the electron multiplier's HV supply. A third small vertical PCB is used to pass signals and power between the two main PCBs.

The bottom PCB holds all of the power electronics for the RF, filament heater, ionizer bias, and system power supplies.

Four PCB's between the two main boards are used:

1. To connect to the probe.
2. For the I/V converter.
3. To pass signals between the main boards.
4. To supply High Voltage to the CDEM.

Description of Schematics

Schematic name: QMSE_T1

Microprocessor

An MC68HC11E9 microcontroller is used to control the system and to communicate with the host computer. This central processing unit (CPU) also has RAM, ROM, EEPROM, UART, octal 8-bit A/D converter, counter timers, and a multiplexed address/data bus to accommodate an external 32Kx8 RAM. The ROM is used for program storage, the RAM for data storage, the EEPROM contains calibration values for the particular unit.

The power-up reset and power-fail interrupts are provided to the CPU by U100, a MAX705.

Digital I/O Ports

The microprocessor's I/O ports are assigned as follows:

PA0	-RTS	Low indicates that the host computer is ready for RS232 data.
PA1	-BUSY	Low indicates that the 16-bit signal A/D converter is busy.
PA2	CAL_EN	High enables modification of EEPROM calibration data.
PA3	LE_DAC18	Set high to latch SPI data into 18-bit (RF control) D/A converter.
PA4	-CS_DAC8	Strobe low to assert CS to octal 8-bit DAC.
PA5	LD_LEDS	Strobe high to load LED data into output register.
PA6	LD_MPX	Strobe high to load multiplexer data into output register.
PA7	LD_MISC	Strobe high to load miscellaneous data into output register.
PB	A8-15	High address bits for external RAM
	0-7	
PC	A0-7 & D0-7	Multiplexed address and data bits for external RAM
	0-7	

PD0	RXD	RS232 data received from host computer.
PD1	TXD	RS232 data transmitted to host computer.
PD2	SPI_IN	Serial peripheral interface data from 16-bit A/D converter.
PD3	SPI_OUT	Serial peripheral interface data to 8 and 18-bit D/A converters.
PD4	SPI_CLK	Serial peripheral interface data clock.
PD5	-CTS	Low to allow host computer to send RS232 data.
PE0	+24/6	A/D input: +24VDC supply divided by 6.
PE1	RF_CT/5	A/D input: RF primary voltage divided by 5.
PE2	RF_PRI	A/D input: RF primary current: 1V/400mA
PE3	GND	A/D input: 0 VDC
PE4	GND	A/D input: 0 VDC
PE5	FOCUS_I	A/D input: focus plate ion current: 1V/5 μ A
PE6	FIL_DUTY	A/D input: filament heater duty cycle: 1V/20%
PE7	FIL_PRI	A/D input: filament heater primary current: 3V/A

In addition to the I/O port on the microcontroller, there are three 8-bit digital shift registers which are loaded via the SPI, then strobed by a LD bit to transfer data to the parts' output registers. The three digital output ports are assigned as follows:

The LED port

Q0	Set high to light an LED to indicate that the +24V power supply is "okay".
Q1	Set high to light an LED to indicate that the filament is "on".
Q2	Set high to light an LED to indicate that the unit is degassing.
Q3	Set high to light an LED to indicate that the CDEM high voltage is "on".
Q4	Strobe high to set I/V converter to LOG mode
Q5	Set high to light an LED to indicate that there has been an error.
Q6	Set high to light an LED to indicate that the pressure is too high.
Q7	Set high to light an LED to indicate that the filament is burnt-out.

The MPX port

Q0	CAL_0	LSB of current detector calibration attenuator multiplexer.
Q1	CAL_1	Middle bit of current detector calibration attenuator multiplexer.

Q2	CAL_2	MSB of current detector calibration attenuator multiplexer.
Q3	MPX_0	LSB of 16-bit A/D converter's input multiplexer.
Q4	MPX_1	Middle bit of 16-bit A/D converter's input multiplexer.
Q5	MPX_2	MSB of 16-bit A/D converter's input multiplexer.
Q6	EMIT_CTL	Filament heater duty cycle control: 0=direct, 1=regulate
Q7	GRID_SEL	Low for low grid potential, high for high grid potential.

The MISC port

Q0	RF_ON	Low to turn-off RF, high to turn on.
Q1	IONS_OFF	Pulse high for 50ms to reset relay so that ion current goes to gnd.
Q2	IONS_ON	Pulse high to set latching relay so ion current enters I/V.
Q3	MULT_OFF	Pulse high to ground e-multiplier anode.
Q4	MULT_ON	Pulse high to connect e-multiplier to I/V.
Q5	LINEAR	Pulse high for linear I/V converter (offset calibration).
Q6	R/-C	Set high to read 16-bit A/D, low to initiate conversion.
Q6	CS_VETO	Set high to prevent (or release) -CS to 16-bit A/D converter.

Clocks

The master clock of the system is an 11.0592 MHz crystal oscillator. This frequency was selected for the following reasons:

1. It is close to the maximum operating frequency for the 68HC11 (12 MHz).
2. When divided by four it provides a usable RF frequency (2.7648 MHz).
3. When divided by 128 it provides a clock for switching power supplies (86.4 kHz).
4. When divided by 256 it provides a clock for the high voltage DC-DC converter.
5. When divided by 384 it provides an exact PC baud rate (28.8 kbaud).
6. When divided by 2^{14} it provides a A/D convert rate (675 Hz).

Since the A/D convert rate is a sub-multiple of all the other system clocks, crosstalk from the clocks will be synchronous, and will generate a fixed offset to the signal (which may be measured and subtracted) instead of noise.

The clock division for the 28.8 kBaud rate is done by the microcontroller; the rest of the clock division is done by U108, a 74HC4020 14-stage ripple divider. The 172.8kHz square wave is formed into a 100ns wide pulse to be used as a switching power supply sync pulse, which is divided by two by the power supply controller. U109, a 74HC74 dual D-type flip-flop, provides the complimentary drive required for the RF and high-voltage inverter circuits. Either of these drives may be turned off (both Q and -Q outputs set high) by setting the control bits RF_ON or HV_ON low.

RS232 Interface

The microcontroller communicates with a host computer via the RS232 interface. The RS232 interface is configured as a DCE (data communications equipment) at a fixed baud rate of 28.8k, with hardware handshaking via CTS (clear-to-send) and RTS (request-to-send), and uses a PC compatible female DB9 connector. So, the quadrupole will transmit data on pin 2, receive data on pin 3, assert CTS on pin 8, and look for RTS on pin 7. Pin 5 is the signal and chassis ground.

Schematic name: QMSE_T2

I/V calibration

The current signal from the Faraday cup or electron multiplier is converted to a voltage by the logarithmic I/V converter (see schematic QMSE_V1). This converter requires careful calibration and bias in order to assure accurate readings over its 8 decade range. A programmable voltage source (U209 and associated components) can provide voltages from microvolts to volts, which are applied to the I/V converter via a 1G Ω resistor to generate calibration currents from femtoamps to nanoamps. The calibration source is also used to bias the I/V converter during scans to establish the bandwidth/noise floor tradeoff.

A second I/V converter channel is biased by the calibration source to allow for temperature compensation of the detection channel. Both I/V converters are biased by equal currents from the calibration source, so that their output voltages are nearly the same when there is no ion current being detected. The outputs of each I/V converter may be read via the 16-bit A/D for calibration and offset nulling. The outputs of the I/V converters are subtracted in a differential amplifier (U211A) with a gain of 5.23 and a bandwidth of 1kHz.

The differential amplifier is followed by a Butterworth filter (U211B) with a gain of 1.59, a -3dB point of 300Hz, and a roll-off of -12dB/octave. The filter is used to reduce the noise on the signal which is above the Nyquist bandwidth for a 675Hz sampling rate. (In low bias current cases, the bandwidth of the signal is much lower, per the diode time constant.) R233 insures that the output of the filter cannot exceed the +/-5V range of the 1:8 multiplexer at the input to the 16-bit A/D converter.

A/D Conversion

Several different signals and a ground reference may be multiplexed to a 16-bit A/D converter by U201, a 74HC4051. The control bits MPX_0-2 are used to select one of the 8 inputs. The selected input is amplified by U202A by 2x to scale the input for the +/-10V range of the A/D converter, U203.

The CPU can measure the offset of the input multiplexer, op-amp, and A/D converter by selecting input X7 (the circuit ground). The measured offset is subtracted from readings taken for the other inputs.

A conversion is initiated by -CS_ADC16 going low while R/-C is low. -CS_ADC16 is asserted when the 675Hz convert clock from the 74HC4020 (U108) goes low provided that CS_VETO (MISC port bit 7) is low. The 675Hz convert clock going low also initiates an -IRQ to the CPU. In response to the

-IRQ, the CPU sets CS_VETO high (which sets -CS_ADC16 high) and sets R/-C high to allow the data to be read. The -BUSY output will remain low for up to 20 μ s during a conversion. When -BUSY goes high, the CPU returns CS_VETO low, which again asserts the -CS_ADC16 (this time with R/-C high), and reads the data from the ADC via the SPI. Since the ADC shifts its data on the rising edge of the data clock (i.e. data should be read on the falling edge of the data clock) the inverted SPI clock is used as the data clock to the ADC. This will also permit simultaneous transmission of data to the 18-bit RF amplitude control D/A. The CPU sets R/-C low after the data is read to prepare the A/D for the next conversion cycle.

Power-up Conditioning

The A/D reference output (+2.50VDC) is amplified, buffered, and inverted by U302A&B to provide system references of +/-5.00VDC. These references are set to zero volts when the system is reset so that other analog signals (such as the HV and filament control signals) will stay at zero until set by the microcontroller.

The triple 2:1 analog switch U301, a 74HC4053, is used to make certain that various circuits remain off when the system is reset, until the CPU can establish the system environment. Upon reset the dual flip-flop U300 is reset. The output of the second flip-flop, which controls all three channels of the analog switch, will return high with the second port strobe from the CPU to the MISC bits port. Immediately following a reset, EMIT_CTL will be low (to multiplex EMIT_SET to control the duty cycle of the filament heater circuit directly), the ± 5.00 REFs will be set to zero (so that all the analog control signals will be zero), and the output current from the 18-bit DAC which controls the RF amplitude will be shunted to ground.

Schematic name: QMSE_T3

DC Control Voltages

U307, a MAX528 octal 8-bit DAC, provides DC voltages to control various parameters in the system. Each output has a range from 0 to 4.98V with a step size of about 19.5mV. The eight outputs and their functions are listed here:

0	RES_CTL	This output (-2.5V and times 1) increases the rods' DC.
1	EMIT_SET	This output (times 1 or 10mA/V) sets the emission current.
4	RPL_SET	This output (times -20) sets the repeller and filament bias.
3	FOC_SET	This output (times -30) sets the focus plate bias.
7	HV_SET	This output (times -500) sets the electron multiplier bias.
5	+OFFSET	This output (-2.5 & times .001) fixes the detector offset.
5	-OFFSET	This output (-2.5 & times .001) fixes the reference offset.
6	CAL	This output (-2.5V then times -2) is the calibration source.

RF Amplitude Detection

The amplitude of the RF is detected by a full-wave charge pump detector. In order to provide a symmetrical load to the generator, the amplitude on both rods is detected and summed. The charge pump works as follows: as the potential on the rod reaches a peak, the 0.5 pF capacitor (C750 on the PCB which holds the flange socket) is charged to the maximum voltage, $V_p + V_{dc} - V_{diode}$ with current flowing to ground via D303, a Schottky diode. During the next half cycle, C750 is charged to $-V_p + V_{DC} + V_{diode}$ with current flowing through D302 from the virtual ground at the inverting input of U305. The total charge transfer to the op-amp is $C \times dV = C \times (V_{pp} - 2V_{diode})$. This charge is pumped every cycle from two charge pumps, so the current is $I = 2fC(V_{pp} - 2V_{diode})$. For $C=0.5\text{pF}$ and $f=2.7648\text{ MHz}$, and ignoring V_{diode} , the current is $2.76\mu\text{A}/V_{pp}$. This current flows through the 698Ω feedback resistor, R312 in parallel with R322, which is selected to calibrate the detector's sensitivity.

The output of the charge pump's I/V converter (U305) is filtered and attenuated by the 3rd order elliptic filter (C303-305 and L300) which has a characteristic impedance of 200Ω and a notch at 5.6MHz, which corresponds to the second harmonic of the detected RF signal. The potentiometer at the output of the filter (P300) is adjusted to provide a voltage of $V_{pp}/1000$. This signal is used as the feedback signal to control the RF amplitude.

The adjustment of P300, the RF amplitude detection gain potentiometer, is very important in order to maintain constant resolution and sensitivity throughout a scan. P300 should be adjusted so that He and Kr have the same resolution with RES_CTL at a fixed nominal level of +2.50VDC. From here, empirical adjustments to RES_CTL vs. amu may be made to optimize the instrument's performance, but to first order, RES_CTL will be a constant. (Factory cal only with DS=0.)

RF Amplitude Control

The detected RF amplitude signal, $V_{PP}/1000$, is compared to the RF level control (RF_SET) from the 18-bit DAC U303. If the detected level is below the set level then the output of U306 slews upward, increasing the primary drive, increasing the RF level, until the RF level reaches the set level. U306 is configured as a differential amplifier with a gain of 5, which uses the ground reference from the bottom PCB, so as to reduce the effects of noise and ground offsets between the PCBs. The CPU may scan the mass filter by ramping the 18-bit DAC output between 8.56mV (for 1 amu) and 2.56V (for 300 amu).

Foldback Current Limiting

The RF output is approximately linear in the RF primary drive current. The scale factors for the detected RF_SET and the measured RF primary drive current ($\text{RF_PRI} = 1.5\text{V/A}$) were chosen so that RF_SET should always be larger than RF_PRI if the system is operating properly. In the case of a failure which causes excessive primary drive current, the output of the difference amplifier, U304B, goes positive as RF_PRI goes above RF_SET. The output of U304 will limit the primary drive current as the current through D304 increases. In this case, which is detected by the CPU as $\text{RF_PRI} > \text{RF_SET}$, the RF level will be less than the level set by the 18-bit DAC.

The 18-bit DAC output is also used to set the DC potentials applied to the mass filter. RF_SET is multiplied by 4 by the differential amplifier U304A, which uses the bottom PCB for its ground reference. The output of U304A is passed to the bottom PCB via JP301 to control the DC bias sources.

Schematic name: QMSE_B1.

Mass filter RF Supply

The Toroid: The design approach was dominated by the characteristics of the RF transformer. This iron-powder toroid provides a step-up of 39:1 for the RF. The secondaries have a self-inductance of about 16 μH so as to resonate at 2.7648 MHz with the capacitive load presented by the rods in the mass filter together with the parasitic capacitance of the secondaries.

The primary of the transformer is a single turn driven by a square wave voltage at 2.7648MHz through a series inductor (T401) of 0.5 μH . The step-up transformer is driven slightly off resonance, so that its input has a capacitive reactance, which resonates with the 0.5 μH inductor at the drive frequency. This approach is used to reduce power losses in the drive circuit (the FETs are switched when the current is nearly zero), and to reduce the distortion in the RF output (as the drive current is very nearly sinusoidal).

Due to variations in the core material used in the step-up transformer, each unit must be tuned by adding capacitors across the primary. This is done by programming the unit to operate at 100 amu, and by finding the combination of capacitors (connected between J401 and J403) which minimize the drive voltage as measured at J400 (which is RF_CT/5). Polypropylene capacitors with a voltage rating of 50V are used to tune the primary reactance for minimum power loss.

The 39 turn secondaries are wound in a very special fashion: the two windings are placed side-by-side so that the magnetic flux seen by the two windings is very nearly identical. Measurements on these transformers show a difference in self-inductance between the two secondaries of less than 0.1%. This is important to assure that the magnitude of the RF for the two secondaries will be very nearly equal. Silver plated, Teflon coated wire is used for the secondaries to reduce skin effect losses and to minimize interwinding capacitance, and to reduce the loss tangent in the dielectric.

Primary Drive: The squarewave voltage drive is provided by a pair of IRF510 MOSFETS, Q402 and Q403. These FETs have delay and transition times on the order of 25ns, and are operated as switches. The gates of the FETs are driven by complimentary square waves at 2.7648MHz with 50% duty cycles from U401, an SN75372. Each FET is on for about 180ns.

The amplitude of the squarewave drive is controlled by the DC supplied by Q401, a D44VH10 high speed npn power transistor. The op-amp U400 integrates the error signal from U306 on the top PCB to maintain the detected RF equal to the signal "RF_SET" from the 18-bit D/A.

The primary current is passed through the FET's 0.25 Ω source resistor. The voltage across this resistor is amplified by U402B and may be read by the CPU. Approximately 1.5A is required to generate 2568Vpp required at 300 amu.

At low drive levels, the charge injected via the gate-source and gate-drain capacitances of Q402/403 are a significant source of error. To compensate, the network of R413, R414 and C406 couple a signal

with the correct amplitude and phase into the primary drive inductor, T401, to cancel the charge injected via the FET gates.

DC Potentials

In addition to the RF, DC potentials of about $\pm 1/12$ th the RF peak-to-peak value is required for the two rod pairs. The op-amp U403A is the error amplifier which maintains the negative potential equal to a fraction of the set RF level. When DC_SET goes up, the output of the op-amp goes up, increasing the current in Q406, increasing the current in Q407, bringing down the collector of Q407, which is the output of the negative potential voltage regulator.

The op-amp U403B is the error amplifier for the positive potential. The positive potential is compared to the negative potential by R431 and R432. When the negative potential increases, the non-inverting input to U403B will go down, lowering the op-amp output, increasing the current in Q405, increasing the current in Q404, thereby increasing the positive potential until it matches the magnitude of the negative potential.

Schematic name: QMSE_B2

Filament Heater Supply

The sensitivity of the quadrupole depends on the filament emission current, which depends on the filament temperature and bias with respect to the grid. As the grid to filament bias is fixed to optimize the electron impact ionization cross-section, the filament emission current is controlled by controlling the filament temperature via the filament heater current's duty cycle.

A switching power supply, which is synchronized to a sub-multiple of the master clock at 172.8kHz, is used to provide heater power to the filament. (Note that two clocks are required for each cycle, so the primary drive current is at 86.4kHz.) The switcher's transformer has a 6:1 turns ratio, reducing the +24V input to a 4V output, which leaves about 3.5V after rectification in the dual Schottky diode, D501.

The primary of the transformer is operated from the +24VDC supply, and is driven differentially by a pair of IRF530 MOSFETs. An LT3525 switching controller, U501, is used to drive the FET gates. The duty cycle of the gate drive depends on the voltage at the COMP pin (pin 9). A voltage of about 0.9V or below will set the duty cycle to zero. The duty cycle increases to a maximum near 50% (for each gate) as the voltage on this input is increased to about 3.3V.

The analog switch, U500, controls the source of the signal to the COMP pin. If EMIT_CTL is low (as it is after a reset) then the DAC signal EMIT_SET is connected directly to the COMP pin allowing for direct control of the filament heater's duty cycle by the CPU. This mode is used when the filament is first turned "on" to verify that the pressure is low enough to allow the filament to remain "on".

When EMIT_CTL is set high, the COMP pin is connected to the compensation capacitor C500, which will be charged and discharged by the transconductance error amplifier in U501. The error amplifier will compare the EMIT_SET voltage (or the attenuated EMIT_SET voltage, depending on the state of the

DE_GAS bit) to the voltage seen on the 100Ω emission current shunt resistor, R522. (The current sensed by this resistor is actually composed of three components: the filament emission current, the repeller voltage/100kΩ, and Vref (+5V)/30kΩ. All of these components sum. With a repeller voltage of -60V, the two non-emission sources sum to $0.60 + 0.166 = 0.766\text{mA}$. So, to set an emission current of 2mA, EMIT_SET, which provides 1mA/V, is set to 2.766VDC.) The emission current may be set to values as high as 50mA during the de-gas procedure.

The primary side current drive may be sensed in the 0.5Ω FET source resistor. The voltage across this resistor is filtered and amplified by 6X, and may be measured by the CPU. The duty cycle of the FET switches may also be measured by the CPU via the voltage labeled "FIL_DUTY". A drop of about 40% in the primary side current for a particular duty cycle value indicates that one of the two parallel filaments has burnt out. A drop of 90% indicates that both filaments are missing.

If the source sense resistor voltage reaches 1V (when the primary side current reaches an instantaneous value of 2A) the LT3525 will terminate the gate drive to FET for the remainder of the cycle. This feature protects the circuit in the case of a short circuit or other severe fault.

Bias Regulators

The regulated repeller and focus plate biases are controlled by the CPU. The set voltages, RPL_SET and FOC_SET are multiplied by -20 and -30, respectively, by the bias regulators.

If the control signal RPL_SET is increased, the non-inverting input (and so the output) of the op-amp U502B will go up, increasing the current in the opto-isolator's LED, increasing Q502's collector current, increasing the magnitude of the (negative) repeller bias.

If the control signal FOC_SET is increased, current is injected via the 61.9kΩ resistors R538 and R539 directly into the emitter of Q506 and away from the emitter of Q505 which are biased at ground. These currents are mirrored by Q503/504 and Q507/508 to the output node, which has a 1MΩ resistance to ground via R531, providing an overall gain of -30.

Imbalances in currents due to focus plate currents or current mirror mismatches are made up by the op-amp U504A. If the output is smaller (less negative) than it should be, the non-inverting input to U504A will be positive, causing its output to ramp up. This increases the current into the emitter of Q506 and decreases the current into Q505. These currents are mirrored to the output, increasing the current in Q508 and decreasing the current in Q504, pulling the output more negative. The output of U504A will go up by 1V for each 1μA of ion current collected by the focus plate. The output may be digitized by the CPU to monitor the ion current in order to watch for excessive operating pressure.

Since the focus plate may collect ions when set to any potential below the grid potential, and since it may collect electrons when set to any potential above the repeller voltage, the focus plate regulator is designed to sink or source current.

The grid voltage is supplied by the op-amp U502A. This op-amp is operated with a gain of six to amplify the voltage selected by the analog switch U500. The op-amp is protected from possible discharges, which would connect the grid to the repeller potential, by R517 and D500.

For a high power de-gas, a DPDT relay is used to by-pass the bias regulators, connecting the grid and repeller directly to the un-regulated +250Vdc and -150Vdc supplies. During de-gas, the filament emission current is set to 20mA, which will provide about 8W of power to heat the grid, in addition to 15W of filament heater power.

Schematic name: QMSE_B3

Power Supplies

The unit is operated from +24VDC, and requires up to 2.0A. (The current draw will be the highest when the unit is scanning at the high end of the mass range, or during de-gas.) The unit is protected against power supply reversal by D610. A 5A circuit board mounted fuse limits damage in the case of a severe circuit failure. The DC input is filtered by C615, L601 and C616, which also reduce conducted emissions from the unit.

A DC-DC inverter is operated from the +24V supply to provide -140V for the repeller, $\pm 250V$ for the mass filter bias sources, and -20V for the negative linear voltage regulators. The primaries to the inverter are driven by FETs. A switching power supply regulator, U601, provides 12V square wave drive voltages to the FETs which are sync'd to a sub-multiple of the master clock. Overcurrent protection is provided by U601 on a cycle by cycle basis. U601 does not regulate the outputs of the inverter, rather, its COMP pin is tied high to provide the maximum duty cycle.

The first of three secondaries is full wave rectified by D611-D614. This output is used only to bias the repeller, which allows the filament emission current to be monitored and controlled with high precision. The next secondary has a pair of half-wave doublers (C635, C636, and D615-D618) to provide $\pm 250V$. The third secondary has a full wave rectifier (D619-D622) to provide -20VDC, which is filtered by C622, C623 and L603.

All three secondaries are balanced so that no DC current is drawn in order to avoid saturation in the un-gapped transformer core of T601.

The positive power supplies (+15 for the op-amps, +12 for the RS232 and MOSFET drivers, +5_CLEAN for the signal multiplexers and A/D converter, and +5 for the logic circuits) are derived via linear three terminal regulators (U602-605) from the +24V supply.

The negative supplies (-15 for the op-amps, -12 for the RS232, and -5 for the A/D and analog multiplexers) are provided by the linear regulators U606-608 from the -20V generated by the main inverter.

Schematic name: QMSE_V1

Signal Conditioning

The output from the mass filter is a very small ion current which is proportional to the pressure of the selected mass. The lowest pressure which may be measured by the instrument is proportional to the

lowest current which may be detected. Extreme care is required to achieve low drift and low noise current measurements at these very low current levels. In addition, the instrument needs to measure a wide range of pressures, which requires current measurements over a wide range.

The sensitivity of the ionizer and mass filter is about $100\mu\text{A/Torr}$, and is nearly constant from 0 to 5×10^{-5} Torr, so we expect ion currents from 0 to 5nA. To accommodate this large dynamic range, a log I/V converter is used, whose output is amplified, filtered, and digitized by a 16-bit A/D converter. (The high resolution A/D is required to assure that the quantization noise of the A/D is smaller than the shot noise of the I/V converter's bias source, and to provide sufficient resolution.)

At the core of the detection system is the log I/V converter. A standard arrangement is used, where the current is applied to the inverting input of a very low bias current op-amp (U700) and a diode is used between the output and the inverting input of the op-amp. Small signal JFETs transistors (Q700/701) are used as diodes, as they have well characterized (and very low) reverse gate leakage currents.

A programmable current source is also applied to the inverting input of the op-amp. This source serves two purposes: it is used to calibrate the gain of the I/V converter (which changes with temperature), and it provides a bias current to the diodes during data collection. As a calibrator, the current source can output currents from 0 to 5nA. As a bias source, it is programmed to provide 500fA to 64pA depending on the speed and sensitivity required for a scan. (High speed scans require high bias currents which reduce the time-constant through the diode, and high sensitivity scans require low bias currents to reduce the shot noise of the bias current source.)

At 500fA bias current, the Johnson noise current of the $1\text{G}\Omega$ current source resistor (about $4\text{fA}/\sqrt{\text{Hz}}$) establishes the noise floor for ion current measurements. At higher bias currents, the shot noise of the bias current establishes the noise floor. For example, shot noise associated with a 500pA bias current is about $12.7\text{fA}/\sqrt{\text{Hz}}$. In addition, the bandwidth of the detector increases with bias current, increasing the noise.

Back-to-back diodes are used to allow either ion currents (Faraday cup case) or electron currents (electron multiplier case) to be measured. During calibration procedures, the ion current is shunted to ground by a latching relay, U701. A latching relay is used so that the relay coil will not be active during either calibrations or measurements.

The input offset voltage of the I/V converter's op-amp is nulled prior to calibrating the converter's gain. This is done by strobing the MISC port bit (LINEAR) high, which activates the relay U702, configuring the op-amp to a linear amplifier with a gain of 1001 for its own input offset voltage. The CPU then adjusts +OFFSET to null the output of the op-amp, nulling its input offset voltage. The I/V converter is returned to the log mode by strobing the LOG bit high.

A second and identical I/V converter resides next to the I/V converter described above. The second I/V converter is operated and calibrated in the exact same manner, however, collected ion currents are not applied to its input. The primary purpose of the second channel is to correct the output of the first I/V converter against temperature effects.

Schematic name: QMSE_V2

Electron Multiplier High Voltage Power Supply

The electron multiplier option extends the operation of the RGA to much lower pressures. By multiplying the ion current before detection in the I/V converter, the signal to noise ratio is not affected by the bias current noise of the I/V converter. Since the gain of the electron multiplier varies rapidly with applied bias, well regulated negative high voltage supply is required.

A switching power supply, synchronized to a sub-multiple of the master clock at 43.2kHz, followed by a voltage multiplier, is used to generate a negative high voltage. The multiplier output is compared to the set level (HV_SET) by an error amplifier (U800A) which controls the voltage on the center tap of the primary via Q800. The primary current in the HV inverter is sensed by R814, a 2.2 Ω resistor. If the primary drive exceeds 230mA, the output of the difference amplifier U800B will go positive, reducing down the primary drive level.

The HV power supply piggy-backs off the vertical interconnect PCB in between the top and bottom PCBs. The HV power supply will only be installed in units which are ordered with the channel electron multiplier option.

Parts Lists

Top Board Parts List

<u>REF.</u>	<u>SRS part#</u>	<u>VALUE</u>	<u>DESCRIPTION</u>
C 100	5-00023-529	.1U	Cap, Monolythic Ceramic, 50V, 20%, Z5U
C 101	5-00221-529	330P	Cap, Monolythic Ceramic, 50V, 20%, Z5U
C 102	5-00221-529	330P	Cap, Monolythic Ceramic, 50V, 20%, Z5U
C 103	5-00285-562	100P	Cap., NPO Monolithic Ceramic, 50v, 5% Ra
C 104	5-00285-562	100P	Cap., NPO Monolithic Ceramic, 50v, 5% Ra
C 105	5-00285-562	100P	Cap., NPO Monolithic Ceramic, 50v, 5% Ra
C 106	5-00023-529	.1U	Cap, Monolythic Ceramic, 50V, 20%, Z5U
C 107	5-00023-529	.1U	Cap, Monolythic Ceramic, 50V, 20%, Z5U
C 108	5-00023-529	.1U	Cap, Monolythic Ceramic, 50V, 20%, Z5U
C 109	5-00023-529	.1U	Cap, Monolythic Ceramic, 50V, 20%, Z5U
C 110	5-00023-529	.1U	Cap, Monolythic Ceramic, 50V, 20%, Z5U
C 111	5-00023-529	.1U	Cap, Monolythic Ceramic, 50V, 20%, Z5U
C 112	5-00023-529	.1U	Cap, Monolythic Ceramic, 50V, 20%, Z5U
C 113	5-00023-529	.1U	Cap, Monolythic Ceramic, 50V, 20%, Z5U
C 114	5-00023-529	.1U	Cap, Monolythic Ceramic, 50V, 20%, Z5U
C 200	5-00100-517	2.2U	Capacitor, Tantalum, 35V, 20%, Rad
C 205	5-00051-512	.015U	Cap, Stacked Metal Film 50V 5% -40/+85c
C 206	5-00051-512	.015U	Cap, Stacked Metal Film 50V 5% -40/+85c
C 207	5-00052-512	.01U	Cap, Stacked Metal Film 50V 5% -40/+85c
C 208	5-00052-512	.01U	Cap, Stacked Metal Film 50V 5% -40/+85c
C 209	5-00285-562	100P	Cap., NPO Monolithic Ceramic, 50v, 5% Ra
C 211	5-00023-529	.1U	Cap, Monolythic Ceramic, 50V, 20%, Z5U
C 212	5-00003-501	10P	Capacitor, Ceramic Disc, 50V, 10%, SL
C 213	5-00219-529	.01U	Cap, Monolythic Ceramic, 50V, 20%, Z5U
C 214	5-00219-529	.01U	Cap, Monolythic Ceramic, 50V, 20%, Z5U
C 215	5-00219-529	.01U	Cap, Monolythic Ceramic, 50V, 20%, Z5U
C 216	5-00219-529	.01U	Cap, Monolythic Ceramic, 50V, 20%, Z5U
C 217	5-00219-529	.01U	Cap, Monolythic Ceramic, 50V, 20%, Z5U
C 300	5-00100-517	2.2U	Capacitor, Tantalum, 35V, 20%, Rad
C 301	5-00023-529	.1U	Cap, Monolythic Ceramic, 50V, 20%, Z5U
C 302	5-00023-529	.1U	Cap, Monolythic Ceramic, 50V, 20%, Z5U

C 303	5-00239-562	680P	Cap., NPO Monolithic Ceramic, 50v, 5% Ra
C 304	5-00233-532	22P	Capacitor, Ceramic Disc, 50V, 10% NPO
C 305	5-00239-562	680P	Cap., NPO Monolithic Ceramic, 50v, 5% Ra
C 306	5-00023-529	.1U	Cap, Monolythic Ceramic, 50V, 20%, Z5U
D 100	3-00010-303	GREEN	LED, T1 Package
D 101	3-00010-303	GREEN	LED, T1 Package
D 102	3-00010-303	GREEN	LED, T1 Package
D 103	3-00010-303	GREEN	LED, T1 Package
D 104	3-00010-303	GREEN	LED, T1 Package
D 105	3-00011-303	RED	LED, T1 Package
D 106	3-00011-303	RED	LED, T1 Package
D 107	3-00011-303	RED	LED, T1 Package
D 108	3-00004-301	1N4148	Diode
D 109	3-00004-301	1N4148	Diode
D 300	3-00203-301	1N5711	Diode
D 301	3-00203-301	1N5711	Diode
D 302	3-00203-301	1N5711	Diode
D 303	3-00203-301	1N5711	Diode
D 304	3-00004-301	1N4148	Diode
D 305	3-00203-301	1N5711	Diode
J 100	1-00143-101	TEST JACK	Vertical Test Jack
J 101	1-00143-101	TEST JACK	Vertical Test Jack
JP100	1-00086-130	3 PIN SI	Connector, Male
JP101	1-00014-160	9 PIN D	Connector, D-Sub, Right Angle PC, Female
JP102	1-00264-131	20 PIN DI	Connector, Female
JP103	1-00086-130	3 PIN SI	Connector, Male
JP200	1-00264-131	20 PIN DI	Connector, Female
JP300	1-00265-131	4 PIN SI	Connector, Female
JP301	1-00264-131	20 PIN DI	Connector, Female
L 300	6-00006-602	33U	Inductor, Radial
M 104	0-00546-000	4-40 BE CU	Hardware, Misc.
P 300	4-00486-441	50	Pot, Multi-Turn Trim, 3/8" Square Top Ad
PC1	7-00671-701	RG TOP	Printed Circuit Board
Q 100	3-00021-325	2N3904	Transistor, TO-92 Package
Q 101	3-00021-325	2N3904	Transistor, TO-92 Package
Q 102	3-00021-325	2N3904	Transistor, TO-92 Package
Q 103	3-00021-325	2N3904	Transistor, TO-92 Package

B-20 Parts Lists

Q 104	3-00021-325	2N3904	Transistor, TO-92 Package
Q 105	3-00021-325	2N3904	Transistor, TO-92 Package
Q 106	3-00021-325	2N3904	Transistor, TO-92 Package
R 100	4-00192-407	49.9K	Resistor, Metal Film, 1/8W, 1%, 50PPM
R 101	4-00138-407	10.0K	Resistor, Metal Film, 1/8W, 1%, 50PPM
R 102	4-00887-407	133K	Resistor, Metal Film, 1/8W, 1%, 50PPM
R 103	4-00138-407	10.0K	Resistor, Metal Film, 1/8W, 1%, 50PPM
R 104	4-00079-401	4.7K	Resistor, Carbon Film, 1/4W, 5%
R 105	4-00034-401	10K	Resistor, Carbon Film, 1/4W, 5%
R 106	4-00031-401	100	Resistor, Carbon Film, 1/4W, 5%
R 107	4-00021-401	1.0K	Resistor, Carbon Film, 1/4W, 5%
R 108	4-00021-401	1.0K	Resistor, Carbon Film, 1/4W, 5%
R 109	4-00021-401	1.0K	Resistor, Carbon Film, 1/4W, 5%
R 110	4-00031-401	100	Resistor, Carbon Film, 1/4W, 5%
R 111	4-00034-401	10K	Resistor, Carbon Film, 1/4W, 5%
R 112	4-00034-401	10K	Resistor, Carbon Film, 1/4W, 5%
R 113	4-00034-401	10K	Resistor, Carbon Film, 1/4W, 5%
R 114	4-00034-401	10K	Resistor, Carbon Film, 1/4W, 5%
R 115	4-00034-401	10K	Resistor, Carbon Film, 1/4W, 5%
R 116	4-00034-401	10K	Resistor, Carbon Film, 1/4W, 5%
R 117	4-00034-401	10K	Resistor, Carbon Film, 1/4W, 5%
R 118	4-00034-401	10K	Resistor, Carbon Film, 1/4W, 5%
R 119	4-00021-401	1.0K	Resistor, Carbon Film, 1/4W, 5%
R 120	4-00021-401	1.0K	Resistor, Carbon Film, 1/4W, 5%
R 121	4-00021-401	1.0K	Resistor, Carbon Film, 1/4W, 5%
R 122	4-00021-401	1.0K	Resistor, Carbon Film, 1/4W, 5%
R 123	4-00021-401	1.0K	Resistor, Carbon Film, 1/4W, 5%
R 124	4-00021-401	1.0K	Resistor, Carbon Film, 1/4W, 5%
R 125	4-00021-401	1.0K	Resistor, Carbon Film, 1/4W, 5%
R 126	4-00021-401	1.0K	Resistor, Carbon Film, 1/4W, 5%
R 127	4-00021-401	1.0K	Resistor, Carbon Film, 1/4W, 5%
R 128	4-00022-401	1.0M	Resistor, Carbon Film, 1/4W, 5%
R 202	4-00138-407	10.0K	Resistor, Metal Film, 1/8W, 1%, 50PPM
R 203	4-00138-407	10.0K	Resistor, Metal Film, 1/8W, 1%, 50PPM
R 204	4-00053-401	200	Resistor, Carbon Film, 1/4W, 5%
R 205	4-00031-401	100	Resistor, Carbon Film, 1/4W, 5%
R 206	4-00479-407	66.5K	Resistor, Metal Film, 1/8W, 1%, 50PPM

R 210	4-00192-407	49.9K	Resistor, Metal Film, 1/8W, 1%, 50PPM
R 211	4-00142-407	100K	Resistor, Metal Film, 1/8W, 1%, 50PPM
R 212	4-00142-407	100K	Resistor, Metal Film, 1/8W, 1%, 50PPM
R 213	4-00192-407	49.9K	Resistor, Metal Film, 1/8W, 1%, 50PPM
R 214	4-00142-407	100K	Resistor, Metal Film, 1/8W, 1%, 50PPM
R 215	4-00138-407	10.0K	Resistor, Metal Film, 1/8W, 1%, 50PPM
R 216	4-00130-407	1.00K	Resistor, Metal Film, 1/8W, 1%, 50PPM
R 217	4-00141-407	100	Resistor, Metal Film, 1/8W, 1%, 50PPM
R 218	4-00892-407	11	Resistor, Metal Film, 1/8W, 1%, 50PPM
R 219	4-00031-401	100	Resistor, Carbon Film, 1/4W, 5%
R 220	4-00031-401	100	Resistor, Carbon Film, 1/4W, 5%
R 221	4-00398-407	499K	Resistor, Metal Film, 1/8W, 1%, 50PPM
R 222	4-00398-407	499K	Resistor, Metal Film, 1/8W, 1%, 50PPM
R 223	4-00131-407	1.00M	Resistor, Metal Film, 1/8W, 1%, 50PPM
R 224	4-00131-407	1.00M	Resistor, Metal Film, 1/8W, 1%, 50PPM
R 225	4-00897-408	1.910K	Resistor, Metal Film, 1/8W, 0.1%, 25ppm
R 226	4-00218-408	10.00K	Resistor, Metal Film, 1/8W, 0.1%, 25ppm
R 227	4-00897-408	1.910K	Resistor, Metal Film, 1/8W, 0.1%, 25ppm
R 228	4-00218-408	10.00K	Resistor, Metal Film, 1/8W, 0.1%, 25ppm
R 229	4-00192-407	49.9K	Resistor, Metal Film, 1/8W, 1%, 50PPM
R 230	4-00192-407	49.9K	Resistor, Metal Film, 1/8W, 1%, 50PPM
R 231	4-00555-407	590	Resistor, Metal Film, 1/8W, 1%, 50PPM
R 232	4-00130-407	1.00K	Resistor, Metal Film, 1/8W, 1%, 50PPM
R 233	4-00376-407	2.87K	Resistor, Metal Film, 1/8W, 1%, 50PPM
R 300	4-00138-407	10.0K	Resistor, Metal Film, 1/8W, 1%, 50PPM
R 301	4-00138-407	10.0K	Resistor, Metal Film, 1/8W, 1%, 50PPM
R 302	4-00164-407	20.0K	Resistor, Metal Film, 1/8W, 1%, 50PPM
R 303	4-00034-401	10K	Resistor, Carbon Film, 1/4W, 5%
R 304	4-00888-401	150K	Resistor, Carbon Film, 1/4W, 5%
R 305	4-00034-401	10K	Resistor, Carbon Film, 1/4W, 5%
R 306	4-00888-401	150K	Resistor, Carbon Film, 1/4W, 5%
R 309	4-00130-407	1.00K	Resistor, Metal Film, 1/8W, 1%, 50PPM
R 310	4-00188-407	4.99K	Resistor, Metal Film, 1/8W, 1%, 50PPM
R 312	4-00202-407	698	Resistor, Metal Film, 1/8W, 1%, 50PPM
R 313	4-00165-407	200	Resistor, Metal Film, 1/8W, 1%, 50PPM
R 314	4-00154-407	150	Resistor, Metal Film, 1/8W, 1%, 50PPM
R 315	4-00130-407	1.00K	Resistor, Metal Film, 1/8W, 1%, 50PPM

B-22 Parts Lists

R 316	4-00021-401	1.0K	Resistor, Carbon Film, 1/4W, 5%
R 317	4-00188-407	4.99K	Resistor, Metal Film, 1/8W, 1%, 50PPM
R 318	4-00188-407	4.99K	Resistor, Metal Film, 1/8W, 1%, 50PPM
R 319	4-00164-407	20.0K	Resistor, Metal Film, 1/8W, 1%, 50PPM
R 320	4-00188-407	4.99K	Resistor, Metal Film, 1/8W, 1%, 50PPM
R 321	4-00164-407	20.0K	Resistor, Metal Film, 1/8W, 1%, 50PPM
R 322	0-00000-000	UNDECIDED PART	Hardware, Misc.
R 323	4-00079-401	4.7K	Resistor, Carbon Film, 1/4W, 5%
SO101	1-00232-150	52 PLCC TH	Socket, THRU-HOLE
SW100	0-00001-000	WIRE	Hardware, Misc.
U 100	3-00637-340	MAX705CPA	Integrated Circuit (Thru-hole Pkg)
U 102	3-00537-340	74HC373	Integrated Circuit (Thru-hole Pkg)
U 103	3-00366-341	32KX8-35	STATIC RAM, I.C.
U 104	3-00109-340	MC1488	Integrated Circuit (Thru-hole Pkg)
U 105	3-00110-340	MC1489	Integrated Circuit (Thru-hole Pkg)
U 106	3-00036-340	74HC00	Integrated Circuit (Thru-hole Pkg)
U 107	6-00185-621	11.0592	Crystal Oscillator
U 108	3-00169-340	74HC4020	Integrated Circuit (Thru-hole Pkg)
U 109	3-00049-340	74HC74	Integrated Circuit (Thru-hole Pkg)
U 110	3-00039-340	74HC14	Integrated Circuit (Thru-hole Pkg)
U 111	3-00265-340	74HC595	Integrated Circuit (Thru-hole Pkg)
U 112	3-00265-340	74HC595	Integrated Circuit (Thru-hole Pkg)
U 113	3-00265-340	74HC595	Integrated Circuit (Thru-hole Pkg)
U 114	3-00039-340	74HC14	Integrated Circuit (Thru-hole Pkg)
U 200	3-00413-340	LM34DZ	Integrated Circuit (Thru-hole Pkg)
U 201	3-00270-340	74HC4051	Integrated Circuit (Thru-hole Pkg)
U 202	3-00508-340	LM358	Integrated Circuit (Thru-hole Pkg)
U 203	3-00636-340	ADS7807P	Integrated Circuit (Thru-hole Pkg)
U 209	3-00270-340	74HC4051	Integrated Circuit (Thru-hole Pkg)
U 211	3-00091-340	LF412	Integrated Circuit (Thru-hole Pkg)
U 300	3-00049-340	74HC74	Integrated Circuit (Thru-hole Pkg)
U 301	3-00385-340	74HC4053	Integrated Circuit (Thru-hole Pkg)
U 302	3-00508-340	LM358	Integrated Circuit (Thru-hole Pkg)
U 303	3-00630-340	AD1861N	Integrated Circuit (Thru-hole Pkg)
U 304	3-00220-340	OP297	Integrated Circuit (Thru-hole Pkg)
U 305	3-00632-340	AD810	Integrated Circuit (Thru-hole Pkg)
U 306	3-00382-340	OP37	Integrated Circuit (Thru-hole Pkg)

U 307	3-00633-340	MAX528CPP	Integrated Circuit (Thru-hole Pkg)
Z 0	0-00042-010	4-40 HEX	Nut, Hex
Z 0	0-00241-021	4-40X3/16PP	Screw, Panhead Phillips
Z 0	1-00087-131	2 PIN JUMPER	Connector, Female

Bottom Board Parts List

<u>REF.</u>	<u>SRS part#</u>	<u>VALUE</u>	<u>DESCRIPTION</u>
C 400	5-00049-566	.001U	Cap, Polyester Film 50V 5% -40/+85c Rad
C 401	5-00100-517	2.2U	Capacitor, Tantalum, 35V, 20%, Rad
C 402	5-00051-512	.015U	Cap, Stacked Metal Film 50V 5% -40/+85c
C 403	5-00023-529	.1U	Cap, Monolythic Ceramic, 50V, 20%, Z5U
C 404	5-00023-529	.1U	Cap, Monolythic Ceramic, 50V, 20%, Z5U
C 405	5-00062-513	.0022U	Capacitor, Mylar/Poly, 50V, 5%, Rad
C 406	5-00023-529	.1U	Cap, Monolythic Ceramic, 50V, 20%, Z5U
C 407	5-00052-512	.01U	Cap, Stacked Metal Film 50V 5% -40/+85c
C 408	5-00161-533	.22U	Capacitor, Metallized Polyester
C 409	5-00161-533	.22U	Capacitor, Metallized Polyester
C 412	5-00171-535	.01U	Capacitor, Polypropylene
C 413	5-00171-535	.01U	Capacitor, Polypropylene
C 414	5-00330-533	.01U 400V 10%	Capacitor, Metallized Polyester
C 415	5-00330-533	.01U 400V 10%	Capacitor, Metallized Polyester
C 416	5-00003-501	10P	Capacitor, Ceramic Disc, 50V, 10%, SL
C 417	5-00003-501	10P	Capacitor, Ceramic Disc, 50V, 10%, SL
C 418	0-00000-000	UNDECIDED PART	Hardware, Misc.
C 419	0-00000-000	UNDECIDED PART	Hardware, Misc.
C 420	0-00000-000	UNDECIDED PART	Hardware, Misc.
C 421	0-00000-000	UNDECIDED PART	Hardware, Misc.
C 422	5-00285-562	100P	Cap., NPO Monolithic Ceramic, 50v, 5% Ra
C 423	5-00121-566	.0047U	Cap, Polyester Film 50V 5% -40/+85c Rad
C 424	5-00121-566	.0047U	Cap, Polyester Film 50V 5% -40/+85c Rad
C 425	5-00005-501	150P	Capacitor, Ceramic Disc, 50V, 10%, SL
C 500	5-00034-526	100U	Capacitor, Electrolytic, 35V, 20%, Rad
C 501	5-00003-501	10P	Capacitor, Ceramic Disc, 50V, 10%, SL
C 502	5-00061-513	.001U	Capacitor, Mylar/Poly, 50V, 5%, Rad
C 503	5-00023-529	.1U	Cap, Monolythic Ceramic, 50V, 20%, Z5U
C 504	5-00023-529	.1U	Cap, Monolythic Ceramic, 50V, 20%, Z5U

B-24 Parts Lists

C 505	5-00329-526	120U	Capacitor, Electrolytic, 35V, 20%, Rad
C 506	5-00264-513	.0015U	Capacitor, Mylar/Poly, 50V, 5%, Rad
C 507	5-00264-513	.0015U	Capacitor, Mylar/Poly, 50V, 5%, Rad
C 508	5-00330-533	.01U 400V 10%	Capacitor, Metallized Polyester
C 509	5-00330-533	.01U 400V 10%	Capacitor, Metallized Polyester
C 510	5-00330-533	.01U 400V 10%	Capacitor, Metallized Polyester
C 511	5-00023-529	.1U	Cap, Monolythic Ceramic, 50V, 20%, Z5U
C 615	5-00329-526	120U	Capacitor, Electrolytic, 35V, 20%, Rad
C 616	5-00329-526	120U	Capacitor, Electrolytic, 35V, 20%, Rad
C 617	5-00061-513	.001U	Capacitor, Mylar/Poly, 50V, 5%, Rad
C 618	5-00329-526	120U	Capacitor, Electrolytic, 35V, 20%, Rad
C 619	5-00157-533	.1U	Capacitor, Metallized Polyester
C 620	5-00157-533	.1U	Capacitor, Metallized Polyester
C 621	5-00157-533	.1U	Capacitor, Metallized Polyester
C 622	5-00100-517	2.2U	Capacitor, Tantalum, 35V, 20%, Rad
C 623	5-00100-517	2.2U	Capacitor, Tantalum, 35V, 20%, Rad
C 624	5-00100-517	2.2U	Capacitor, Tantalum, 35V, 20%, Rad
C 625	5-00100-517	2.2U	Capacitor, Tantalum, 35V, 20%, Rad
C 626	5-00100-517	2.2U	Capacitor, Tantalum, 35V, 20%, Rad
C 627	5-00100-517	2.2U	Capacitor, Tantalum, 35V, 20%, Rad
C 628	5-00100-517	2.2U	Capacitor, Tantalum, 35V, 20%, Rad
C 629	5-00100-517	2.2U	Capacitor, Tantalum, 35V, 20%, Rad
C 630	5-00100-517	2.2U	Capacitor, Tantalum, 35V, 20%, Rad
C 631	5-00100-517	2.2U	Capacitor, Tantalum, 35V, 20%, Rad
C 632	5-00100-517	2.2U	Capacitor, Tantalum, 35V, 20%, Rad
C 633	5-00100-517	2.2U	Capacitor, Tantalum, 35V, 20%, Rad
C 634	5-00100-517	2.2U	Capacitor, Tantalum, 35V, 20%, Rad
C 635	5-00157-533	.1U	Capacitor, Metallized Polyester
C 636	5-00157-533	.1U	Capacitor, Metallized Polyester
CX501	5-00100-517	2.2U	Capacitor, Tantalum, 35V, 20%, Rad
CX601	5-00100-517	2.2U	Capacitor, Tantalum, 35V, 20%, Rad
D 400	3-00004-301	1N4148	Diode
D 401	3-00004-301	1N4148	Diode
D 402	3-00203-301	1N5711	Diode
D 403	3-00203-301	1N5711	Diode
D 500	3-00001-301	1N4001	Diode
D 502	3-00004-301	1N4148	Diode

D 503	3-00004-301	1N4148	Diode
D 504	3-00004-301	1N4148	Diode
D 505	3-00203-301	1N5711	Diode
D 506	3-00004-301	1N4148	Diode
D 611	3-00228-301	MUR160	Diode
D 612	3-00228-301	MUR160	Diode
D 613	3-00228-301	MUR160	Diode
D 614	3-00228-301	MUR160	Diode
D 615	3-00228-301	MUR160	Diode
D 616	3-00228-301	MUR160	Diode
D 617	3-00228-301	MUR160	Diode
D 618	3-00228-301	MUR160	Diode
D 619	3-00228-301	MUR160	Diode
D 620	3-00228-301	MUR160	Diode
D 621	3-00228-301	MUR160	Diode
D 622	3-00228-301	MUR160	Diode
D 623	3-00625-302	MBR1535CT	Diode, Dual Schottky
F 600	6-00135-611	5A 2AG	Fuse
JP400	1-00264-131	20 PIN DI	Connector, Female
JP500	1-00270-130	4 PIN SI	Connector, Male
JP501	1-00270-130	4 PIN SI	Connector, Male
JP600	1-00269-159	9 PIN	Connector, D-Sub, Right Angle PC, Male
JP601	1-00264-131	20 PIN DI	Connector, Female
L 400	6-00174-630	6611 TYPE 43	Ferrite Beads
L 401	6-00174-630	6611 TYPE 43	Ferrite Beads
L 500	6-00174-630	6611 TYPE 43	Ferrite Beads
L 501	0-00001-000	WIRE	Hardware, Misc.
L 601	6-00174-630	6611 TYPE 43	Ferrite Beads
L 602	6-00174-630	6611 TYPE 43	Ferrite Beads
L 603	6-00174-630	6611 TYPE 43	Ferrite Beads
LX400	0-00772-000	1.5" WIRE	Hardware, Misc.
LX401	0-00772-000	1.5" WIRE	Hardware, Misc.
LX500	0-00772-000	1.5" WIRE	Hardware, Misc.
LX601	0-00772-000	1.5" WIRE	Hardware, Misc.
LX602	0-00772-000	1.5" WIRE	Hardware, Misc.
LX603	0-00772-000	1.5" WIRE	Hardware, Misc.
M 404	0-00546-000	4-40 BE CU	Hardware, Misc.

B-26 Parts Lists

PC1	7-00670-701	RGA BOTTOM	Printed Circuit Board
Q 400	3-00022-325	2N3906	Transistor, TO-92 Package
Q 404	3-00627-325	MPSA92	Transistor, TO-92 Package
Q 405	3-00628-325	MPSA42	Transistor, TO-92 Package
Q 406	3-00627-325	MPSA92	Transistor, TO-92 Package
Q 407	3-00628-325	MPSA42	Transistor, TO-92 Package
Q 502	3-00644-329	TIP48/TIP47	Voltage Reg., TO-220 (TAB) Package
Q 503	3-00627-325	MPSA92	Transistor, TO-92 Package
Q 504	3-00627-325	MPSA92	Transistor, TO-92 Package
Q 505	3-00628-325	MPSA42	Transistor, TO-92 Package
Q 506	3-00627-325	MPSA92	Transistor, TO-92 Package
Q 507	3-00628-325	MPSA42	Transistor, TO-92 Package
Q 508	3-00628-325	MPSA42	Transistor, TO-92 Package
R 400	4-00800-401	1	Resistor, Carbon Film, 1/4W, 5%
R 401	4-00022-401	1.0M	Resistor, Carbon Film, 1/4W, 5%
R 402	4-00031-401	100	Resistor, Carbon Film, 1/4W, 5%
R 403	4-00188-407	4.99K	Resistor, Metal Film, 1/8W, 1%, 50PPM
R 404	4-00889-401	110	Resistor, Carbon Film, 1/4W, 5%
R 405	4-00138-407	10.0K	Resistor, Metal Film, 1/8W, 1%, 50PPM
R 406	4-00021-401	1.0K	Resistor, Carbon Film, 1/4W, 5%
R 407	4-00021-401	1.0K	Resistor, Carbon Film, 1/4W, 5%
R 408	4-00031-401	100	Resistor, Carbon Film, 1/4W, 5%
R 409	4-00557-407	40.2K	Resistor, Metal Film, 1/8W, 1%, 50PPM
R 410	4-00138-407	10.0K	Resistor, Metal Film, 1/8W, 1%, 50PPM
R 411	4-00034-401	10K	Resistor, Carbon Film, 1/4W, 5%
R 412	4-00056-401	22	Resistor, Carbon Film, 1/4W, 5%
R 413	4-00043-401	180	Resistor, Carbon Film, 1/4W, 5%
R 414	4-00043-401	180	Resistor, Carbon Film, 1/4W, 5%
R 415	4-00800-401	1	Resistor, Carbon Film, 1/4W, 5%
R 416	4-00800-401	1	Resistor, Carbon Film, 1/4W, 5%
R 417	4-00800-401	1	Resistor, Carbon Film, 1/4W, 5%
R 418	4-00800-401	1	Resistor, Carbon Film, 1/4W, 5%
R 419	4-00034-401	10K	Resistor, Carbon Film, 1/4W, 5%
R 420	4-00192-407	49.9K	Resistor, Metal Film, 1/8W, 1%, 50PPM
R 421	4-00138-407	10.0K	Resistor, Metal Film, 1/8W, 1%, 50PPM
R 422	4-00446-407	47.5K	Resistor, Metal Film, 1/8W, 1%, 50PPM
R 423	4-00131-407	1.00M	Resistor, Metal Film, 1/8W, 1%, 50PPM

R 424	4-00405-407	2.49M	Resistor, Metal Film, 1/8W, 1%, 50PPM
R 425	4-00034-401	10K	Resistor, Carbon Film, 1/4W, 5%
R 426	4-00188-407	4.99K	Resistor, Metal Film, 1/8W, 1%, 50PPM
R 427	4-00074-401	33K	Resistor, Carbon Film, 1/4W, 5%
R 428	4-00022-401	1.0M	Resistor, Carbon Film, 1/4W, 5%
R 429	4-00034-401	10K	Resistor, Carbon Film, 1/4W, 5%
R 430	4-00083-401	47K	Resistor, Carbon Film, 1/4W, 5%
R 431	4-00890-408	1.000M	Resistor, Metal Film, 1/8W, 0.1%, 25ppm
R 432	4-00890-408	1.000M	Resistor, Metal Film, 1/8W, 0.1%, 25ppm
R 433	4-00022-401	1.0M	Resistor, Carbon Film, 1/4W, 5%
R 434	4-00022-401	1.0M	Resistor, Carbon Film, 1/4W, 5%
R 435	4-00021-401	1.0K	Resistor, Carbon Film, 1/4W, 5%
R 436	4-00021-401	1.0K	Resistor, Carbon Film, 1/4W, 5%
R 437	4-00131-407	1.00M	Resistor, Metal Film, 1/8W, 1%, 50PPM
R 438	4-00034-401	10K	Resistor, Carbon Film, 1/4W, 5%
R 439	4-00074-401	33K	Resistor, Carbon Film, 1/4W, 5%
R 440	4-00034-401	10K	Resistor, Carbon Film, 1/4W, 5%
R 441	4-00188-407	4.99K	Resistor, Metal Film, 1/8W, 1%, 50PPM
R 442	4-00079-401	4.7K	Resistor, Carbon Film, 1/4W, 5%
R 443	4-00079-401	4.7K	Resistor, Carbon Film, 1/4W, 5%
R 444	4-00081-401	470	Resistor, Carbon Film, 1/4W, 5%
R 500	4-00168-407	22.6K	Resistor, Metal Film, 1/8W, 1%, 50PPM
R 501	4-00188-407	4.99K	Resistor, Metal Film, 1/8W, 1%, 50PPM
R 502	4-00138-407	10.0K	Resistor, Metal Film, 1/8W, 1%, 50PPM
R 503	4-00142-407	100K	Resistor, Metal Film, 1/8W, 1%, 50PPM
R 504	4-00473-407	11.0K	Resistor, Metal Film, 1/8W, 1%, 50PPM
R 505	4-00138-407	10.0K	Resistor, Metal Film, 1/8W, 1%, 50PPM
R 506	4-00164-407	20.0K	Resistor, Metal Film, 1/8W, 1%, 50PPM
R 507	4-00164-407	20.0K	Resistor, Metal Film, 1/8W, 1%, 50PPM
R 508	4-00138-407	10.0K	Resistor, Metal Film, 1/8W, 1%, 50PPM
R 509	4-00303-407	7.87K	Resistor, Metal Film, 1/8W, 1%, 50PPM
R 510	4-00138-407	10.0K	Resistor, Metal Film, 1/8W, 1%, 50PPM
R 511	4-00192-407	49.9K	Resistor, Metal Film, 1/8W, 1%, 50PPM
R 513	4-00034-401	10K	Resistor, Carbon Film, 1/4W, 5%
R 514	4-00034-401	10K	Resistor, Carbon Film, 1/4W, 5%
R 515	4-00800-401	1	Resistor, Carbon Film, 1/4W, 5%
R 516	4-00800-401	1	Resistor, Carbon Film, 1/4W, 5%

B-28 Parts Lists

R 517	4-00141-407	100	Resistor, Metal Film, 1/8W, 1%, 50PPM
R 518	4-00031-401	100	Resistor, Carbon Film, 1/4W, 5%
R 519	4-00034-401	10K	Resistor, Carbon Film, 1/4W, 5%
R 520	4-00192-407	49.9K	Resistor, Metal Film, 1/8W, 1%, 50PPM
R 521	4-00138-407	10.0K	Resistor, Metal Film, 1/8W, 1%, 50PPM
R 522	4-00141-407	100	Resistor, Metal Film, 1/8W, 1%, 50PPM
R 523	4-00188-407	4.99K	Resistor, Metal Film, 1/8W, 1%, 50PPM
R 524	4-00032-401	100K	Resistor, Carbon Film, 1/4W, 5%
R 525	4-00034-401	10K	Resistor, Carbon Film, 1/4W, 5%
R 526	4-00048-401	2.2K	Resistor, Carbon Film, 1/4W, 5%
R 527	4-00079-401	4.7K	Resistor, Carbon Film, 1/4W, 5%
R 528	4-00021-401	1.0K	Resistor, Carbon Film, 1/4W, 5%
R 529	4-00457-407	33.2K	Resistor, Metal Film, 1/8W, 1%, 50PPM
R 530	4-00034-401	10K	Resistor, Carbon Film, 1/4W, 5%
R 531	4-00131-407	1.00M	Resistor, Metal Film, 1/8W, 1%, 50PPM
R 532	4-00131-407	1.00M	Resistor, Metal Film, 1/8W, 1%, 50PPM
R 533	4-00131-407	1.00M	Resistor, Metal Film, 1/8W, 1%, 50PPM
R 534	4-00294-407	24.9K	Resistor, Metal Film, 1/8W, 1%, 50PPM
R 535	4-00131-407	1.00M	Resistor, Metal Film, 1/8W, 1%, 50PPM
R 536	4-00398-407	499K	Resistor, Metal Film, 1/8W, 1%, 50PPM
R 537	4-00131-407	1.00M	Resistor, Metal Film, 1/8W, 1%, 50PPM
R 538	4-00390-407	61.9K	Resistor, Metal Film, 1/8W, 1%, 50PPM
R 539	4-00390-407	61.9K	Resistor, Metal Film, 1/8W, 1%, 50PPM
R 540	4-00294-407	24.9K	Resistor, Metal Film, 1/8W, 1%, 50PPM
R 541	4-00398-407	499K	Resistor, Metal Film, 1/8W, 1%, 50PPM
R 542	4-00398-407	499K	Resistor, Metal Film, 1/8W, 1%, 50PPM
R 543	4-00021-401	1.0K	Resistor, Carbon Film, 1/4W, 5%
R 544	4-00138-407	10.0K	Resistor, Metal Film, 1/8W, 1%, 50PPM
R 545	4-00164-407	20.0K	Resistor, Metal Film, 1/8W, 1%, 50PPM
R 546	4-00138-407	10.0K	Resistor, Metal Film, 1/8W, 1%, 50PPM
R 547	4-00034-401	10K	Resistor, Carbon Film, 1/4W, 5%
R 548	4-00032-401	100K	Resistor, Carbon Film, 1/4W, 5%
R 549	4-00032-401	100K	Resistor, Carbon Film, 1/4W, 5%
R 550	4-00021-401	1.0K	Resistor, Carbon Film, 1/4W, 5%
R 551	4-00083-401	47K	Resistor, Carbon Film, 1/4W, 5%
R 615	4-00303-407	7.87K	Resistor, Metal Film, 1/8W, 1%, 50PPM
R 616	4-00800-401	1	Resistor, Carbon Film, 1/4W, 5%

R 617	4-00800-401	1	Resistor, Carbon Film, 1/4W, 5%
R 618	4-00058-401	220K	Resistor, Carbon Film, 1/4W, 5%
RL500	3-00196-335	HS-212S-5	Relay
T 400	6-00009-610	T1-1-X65	Transformer
T 401	6-00197-601	RF PRIMARY	Inductor
T 500	6-00200-610	RGA FILAMENT	Transformer
T 601	6-00199-610	RGA INVERTER	Transformer
U 400	3-00090-340	LF411	Integrated Circuit (Thru-hole Pkg)
U 401	3-00286-340	SN75372	Integrated Circuit (Thru-hole Pkg)
U 402	3-00508-340	LM358	Integrated Circuit (Thru-hole Pkg)
U 403	3-00220-340	OP297	Integrated Circuit (Thru-hole Pkg)
U 500	3-00385-340	74HC4053	Integrated Circuit (Thru-hole Pkg)
U 501	3-00634-340	3525A	Integrated Circuit (Thru-hole Pkg)
U 502	3-00508-340	LM358	Integrated Circuit (Thru-hole Pkg)
U 503	3-00508-340	LM358	Integrated Circuit (Thru-hole Pkg)
U 504	3-00508-340	LM358	Integrated Circuit (Thru-hole Pkg)
U 505	3-00410-309	MOC8204	Optical Switch
U 601	3-00634-340	3525A	Integrated Circuit (Thru-hole Pkg)
U 603	3-00112-329	7805	Voltage Reg., TO-220 (TAB) Package
U 605	3-00346-329	7812	Voltage Reg., TO-220 (TAB) Package
U 606	3-00330-329	7912	Voltage Reg., TO-220 (TAB) Package
U 608	3-00119-329	7905	Voltage Reg., TO-220 (TAB) Package
Z 0	0-00042-010	4-40 HEX	Nut, Hex
Z 0	0-00241-021	4-40X3/16PP	Screw, Panhead Phillips
Z 0	0-00342-000	FUSEHOLDER 2AG	Hardware, Misc.
Z 0	1-00006-130	2 PIN DI	Connector, Male
Z 0	1-00250-116	2 PIN, WHITE	Header, Amp, MTA-156

Vertical Board Parts List

<u>REF.</u>	<u>SRS part#</u>	<u>VALUE</u>	<u>DESCRIPTION</u>
C 700	5-00023-529	.1U	Cap, Monolythic Ceramic, 50V, 20%, Z5U
C 701	5-00023-529	.1U	Cap, Monolythic Ceramic, 50V, 20%, Z5U
C 750	5-00339-574	.5P 500V SMT	SMT, High Voltage Porcelain Cap.
C 751	5-00339-574	.5P 500V SMT	SMT, High Voltage Porcelain Cap.
C 800	5-00060-512	1.0U	Cap, Stacked Metal Film 50V 5% -40/+85c
C 801	5-00100-517	2.2U	Capacitor, Tantalum, 35V, 20%, Rad
C 806	5-00143-536	1200P	Capacitor, Ceramic, 1000 VDCW
C 807	5-00143-536	1200P	Capacitor, Ceramic, 1000 VDCW
C 808	5-00143-536	1200P	Capacitor, Ceramic, 1000 VDCW
C 809	5-00143-536	1200P	Capacitor, Ceramic, 1000 VDCW
C 810	5-00143-536	1200P	Capacitor, Ceramic, 1000 VDCW
C 811	5-00143-536	1200P	Capacitor, Ceramic, 1000 VDCW
C 812	5-00143-536	1200P	Capacitor, Ceramic, 1000 VDCW
C 813	5-00143-536	1200P	Capacitor, Ceramic, 1000 VDCW
C 814	5-00143-536	1200P	Capacitor, Ceramic, 1000 VDCW
C 815	5-00143-536	1200P	Capacitor, Ceramic, 1000 VDCW
C 816	5-00331-560	1000P/.001U	Capacitor, Ceramic Disc, 3KV
C 817	5-00332-560	100P	Capacitor, Ceramic Disc, 3KV
C 818	5-00054-512	.047U	Cap, Stacked Metal Film 50V 5% -40/+85c
C 819	5-00023-529	.1U	Cap, Monolythic Ceramic, 50V, 20%, Z5U
C 820	5-00052-512	.01U	Cap, Stacked Metal Film 50V 5% -40/+85c
D 501	3-00625-302	MBR1535CT	Diode, Dual Schottky
D 610	3-00625-302	MBR1535CT	Diode, Dual Schottky
D 800	3-00004-301	1N4148	Diode
D 801	3-00004-301	1N4148	Diode
D 802	3-00626-301	MUR1100E	Diode
D 803	3-00626-301	MUR1100E	Diode
D 804	3-00626-301	MUR1100E	Diode
D 805	3-00626-301	MUR1100E	Diode
D 806	3-00626-301	MUR1100E	Diode
D 807	3-00626-301	MUR1100E	Diode
D 808	3-00626-301	MUR1100E	Diode
D 809	3-00626-301	MUR1100E	Diode

D 810	3-00626-301	MUR1100E	Diode
D 811	3-00626-301	MUR1100E	Diode
D 812	3-00004-301	1N4148	Diode
J 701	1-00268-120	PUSH-ON RG58	Connector, BNC
JP700	1-00266-130	20 PIN DI RA	Connector, Male
JP750	1-00271-131	4 PIN SI SIDE	Connector, Female
JP751	1-00271-131	4 PIN SI SIDE	Connector, Female
JP752	1-00267-130	4 PIN SI RA	Connector, Male
JP800	1-00263-130	20 PIN DI	Connector, Male
JP850	1-00264-131	20 PIN DI	Connector, Female
JP852	1-00266-130	20 PIN DI RA	Connector, Male
JP853	1-00266-130	20 PIN DI RA	Connector, Male
JP854	1-00266-130	20 PIN DI RA	Connector, Male
JP855	1-00266-130	20 PIN DI RA	Connector, Male
L 402	6-00502-601	RF XFRMR T131-6	Inductor
L 800	6-00174-630	6611 TYPE 43	Ferrite Beads
LX800	0-00772-000	1.5" WIRE	Hardware, Misc.
PC1	7-00669-701	RGA VERTICALS	Printed Circuit Board
Q 401	3-00082-329	D44VH10	Voltage Reg., TO-220 (TAB) Package
Q 402	3-00629-329	IRF510	Voltage Reg., TO-220 (TAB) Package
Q 403	3-00629-329	IRF510	Voltage Reg., TO-220 (TAB) Package
Q 500	3-00283-340	IRF530/IRF532	Integrated Circuit (Thru-hole Pkg)
Q 501	3-00283-340	IRF530/IRF532	Integrated Circuit (Thru-hole Pkg)
Q 604	3-00283-340	IRF530/IRF532	Integrated Circuit (Thru-hole Pkg)
Q 605	3-00283-340	IRF530/IRF532	Integrated Circuit (Thru-hole Pkg)
Q 700	3-00635-325	PN4117A	Transistor, TO-92 Package
Q 701	3-00635-325	PN4117A	Transistor, TO-92 Package
Q 702	3-00635-325	PN4117A	Transistor, TO-92 Package
Q 703	3-00635-325	PN4117A	Transistor, TO-92 Package
Q 800	3-00082-329	D44VH10	Voltage Reg., TO-220 (TAB) Package
Q 801	3-00021-325	2N3904	Transistor, TO-92 Package
Q 802	3-00021-325	2N3904	Transistor, TO-92 Package
R 700	4-00035-401	10M	Resistor, Carbon Film, 1/4W, 5%
R 701	4-00035-401	10M	Resistor, Carbon Film, 1/4W, 5%
R 702	4-00857-458	1.0G .5W 200PPM	Resistor, Metal Oxide
R 703	4-00857-458	1.0G .5W 200PPM	Resistor, Metal Oxide
R 704	4-00193-407	499	Resistor, Metal Film, 1/8W, 1%, 50PPM

B-32 Parts Lists

R 705	4-00193-407	499	Resistor, Metal Film, 1/8W, 1%, 50PPM
R 706	4-00032-401	100K	Resistor, Carbon Film, 1/4W, 5%
R 707	4-00031-401	100	Resistor, Carbon Film, 1/4W, 5%
R 708	4-00031-401	100	Resistor, Carbon Film, 1/4W, 5%
R 709	4-00032-401	100K	Resistor, Carbon Film, 1/4W, 5%
R 800	4-00166-407	200K	Resistor, Metal Film, 1/8W, 1%, 50PPM
R 801	4-00034-401	10K	Resistor, Carbon Film, 1/4W, 5%
R 802	4-00034-401	10K	Resistor, Carbon Film, 1/4W, 5%
R 803	4-00074-401	33K	Resistor, Carbon Film, 1/4W, 5%
R 804	4-00031-401	100	Resistor, Carbon Film, 1/4W, 5%
R 805	4-00192-407	49.9K	Resistor, Metal Film, 1/8W, 1%, 50PPM
R 806	4-00130-407	1.00K	Resistor, Metal Film, 1/8W, 1%, 50PPM
R 809	4-00891-458	100M .5W	Resistor, Metal Oxide
R 810	4-00131-407	1.00M	Resistor, Metal Film, 1/8W, 1%, 50PPM
R 812	4-00138-407	10.0K	Resistor, Metal Film, 1/8W, 1%, 50PPM
R 813	4-00142-407	100K	Resistor, Metal Film, 1/8W, 1%, 50PPM
R 814	4-00047-401	2.2	Resistor, Carbon Film, 1/4W, 5%
RL700	3-00523-335	G6AK-234P-ST-UC	Relay
RL701	3-00523-335	G6AK-234P-ST-UC	Relay
RL702	3-00523-335	G6AK-234P-ST-UC	Relay
T 800	6-00201-610	RGA HIGH VOLTAGE	Transformer
U 602	3-00114-329	7815	Voltage Reg., TO-220 (TAB) Package
U 604	3-00112-329	7805	Voltage Reg., TO-220 (TAB) Package
U 607	3-00120-329	7915	Voltage Reg., TO-220 (TAB) Package
U 700	3-00631-340	AD549LH	Integrated Circuit (Thru-hole Pkg)
U 701	3-00631-340	AD549LH	Integrated Circuit (Thru-hole Pkg)
U 800	3-00091-340	LF412	Integrated Circuit (Thru-hole Pkg)
Z 0	0-00043-011	4-40 KEP	Nut, Kep
Z 0	0-00079-031	4-40X3/16 M/F	Standoff
Z 0	0-00089-033	4"	Tie
Z 0	0-00096-041	#4 SPLIT	Washer, Split
Z 0	0-00122-053	2-1/4" #24	Wire #24 UL1007 Strip 1/4x1/4 Tin
Z 0	0-00125-050	3" #18	Wire #18 UL1007 Stripped 3/8x3/8 No Tin
Z 0	0-00187-021	4-40X1/4PP	Screw, Panhead Phillips
Z 0	0-00231-043	#4 SHOULDER	Washer, nylon
Z 0	0-00238-026	6-32X1/4PF	Screw, Black, All Types
Z 0	0-00259-021	4-40X1/2"PP	Screw, Panhead Phillips

Z0	0-00308-021	4-40X7/8PP	Screw, Panhead Phillips
Z0	0-00316-003	PLTFM-28	Insulators
Z0	0-00317-000	40MM 24V	Hardware, Misc.
Z0	0-00551-000	40MM FAN GUARD	Hardware, Misc.
Z0	0-00588-030	#4X5/16"	Spacer
Z0	0-00589-026	4-40X5/16"PF	Screw, Black, All Types
Z0	0-00614-021	4-40X1-1/4PP	Screw, Panhead Phillips
Z0	0-00617-031	4-40X1-3/16 F/F	Standoff
Z0	0-00627-056	SOUND/AUDIO 1PR	Cable, Coax & Misc.
Z0	0-00638-055	HV - UL3239	Wire, Other
Z0	1-00230-100	1/6/65	Connector, Misc.
Z0	1-00277-170	RS232 SER DB9	Cable Assembly, Multiconductor
Z0	1-00279-100	DB9M-DB25F	Connector, Misc.
Z0	1-00311-165	9 PIN SOLDR CUP	Connector, D-Sub, Female
Z0	1-00312-178	CABLE CLAMP	Connector Housing, Plug
Z0	7-00664-720	RGA CHASSIS	Fabricated Part
Z0	7-00665-720	MS-38	Fabricated Part
Z0	7-00668-720	MS-41	Fabricated Part
Z0	7-00710-709	MYLAR INSULATOR	Lexan Overlay
Z0	9-00396-907	3/8" RED	Shrink Tubing
Z0	9-00544-907	#7 PVC CLEAR	Shrink Tubing
Z0	9-00569-907	#16 TEFLON INS.	Shrink Tubing

Appendix C. Drawings & Schematics

This appendix contains foldout drawings & schematics referred to in previous chapters.

System Schematics

- QMS Wiring Diagram
- Microcontroller PCB Diagram
- MCA_C1
- MCA_C2
- MCA_D1

Probe Drawings

- Feed-through Flange Connectors
- Probe Assembly

RGA Schematics

- RGA ECU PCB Diagrams
- QMSE_T1
- QMSE_T2
- QMSE_T3
- QMSE_B1
- QMSE_B2
- QMSE_B3
- QMSE_V1
- QMSE_V2

Declaration of Contamination of Vacuum Equipment

The repair and/or service of vacuum equipment or components can only be carried out if a completed declaration has been submitted. SRS reserves the right to refuse acceptance of vacuum equipment submitted for repair or maintenance work where the declaration has been omitted or has not been fully or correctly completed. SRS also reserves the right to refuse servicing any vacuum equipment which could potentially be harmful to the personnel carrying out the repair and service of the equipment. Contact SRS to request additional copies of this form or if you have any questions regarding the contents of this declaration.

Description of equipment

Equipment type/model: _____

Serial No: _____

Reason for return (circle one): • Repair • Maintenance

Please describe: _____

Equipment condition

1. Has the equipment been used ? (circle one) • Yes • No

2. Describe the operating environment the instrument was exposed to:

1. Was any of the equipment exposed to potentially harmful substances? (circle one)

• No

• Yes. Please attach list of all known harmful substances including chemical name and symbol, precautions associated with the substance and first aid measures in the event of accident.

Were any of the harmful substances:

◆ Radioactive?	• Yes	• No
◆ Toxic?	• Yes	• No
◆ Corrosive?	• Yes	• No
◆ Explosive?	• Yes	• No

Was equipment decontaminated/cleaned before being shipped to SRS?

• Yes • No • Not Applicable

◆ <i>SRS will not service any equipment that might potentially be harmful to its service personnel.</i>
◆ <i>SRS will not accept any equipment which has been radioactively, or explosively contaminated without written evidence that such equipment has been properly decontaminated.</i>

Legally Binding Declaration

I hereby declare that the information supplied on this form is complete and accurate. The dispatch of equipment will be in accordance with the appropriate regulations covering Packaging, Transportation and Labeling of Dangerous Substances.

Name (print): _____

Job Title: _____

Organization: _____

Address: _____

Telephone: _____ Fax: _____

Legally binding signature: _____ Date: _____

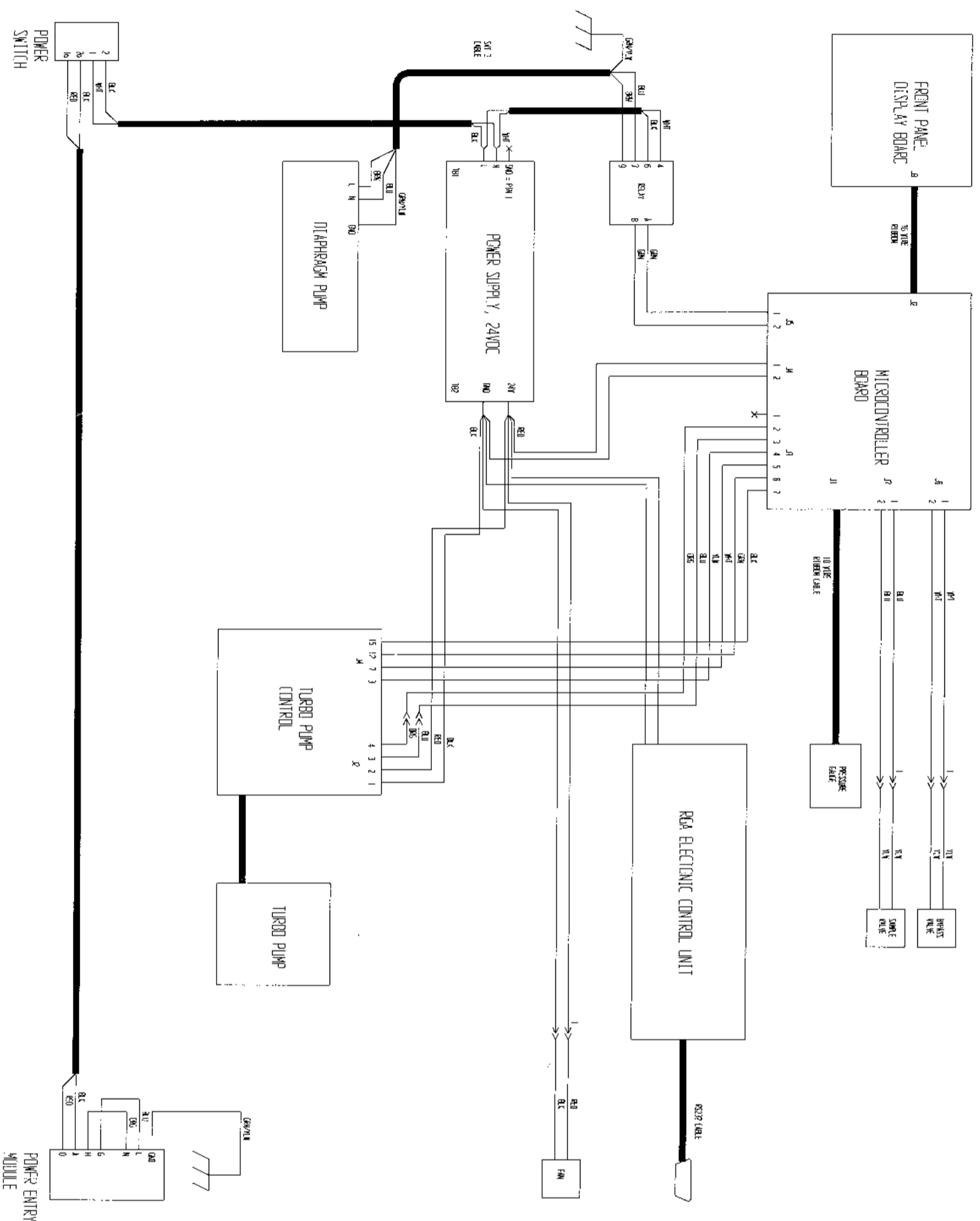

		STANFORD RESEARCH SYSTEMS, INC. 1290-D BARKWOOD AVENUE SUNNYVALE, CALIFORNIA 94089 TEL (408) 744-9040 FAX (408) 744-9049	
DWG # dr/pw059.prt		TITLE: GMS Wiring Diagram	
SIZE: B	PART #	SCALE: N/A	DATE: 3 DEC 96
REV 0		SHEET 1 of 1	

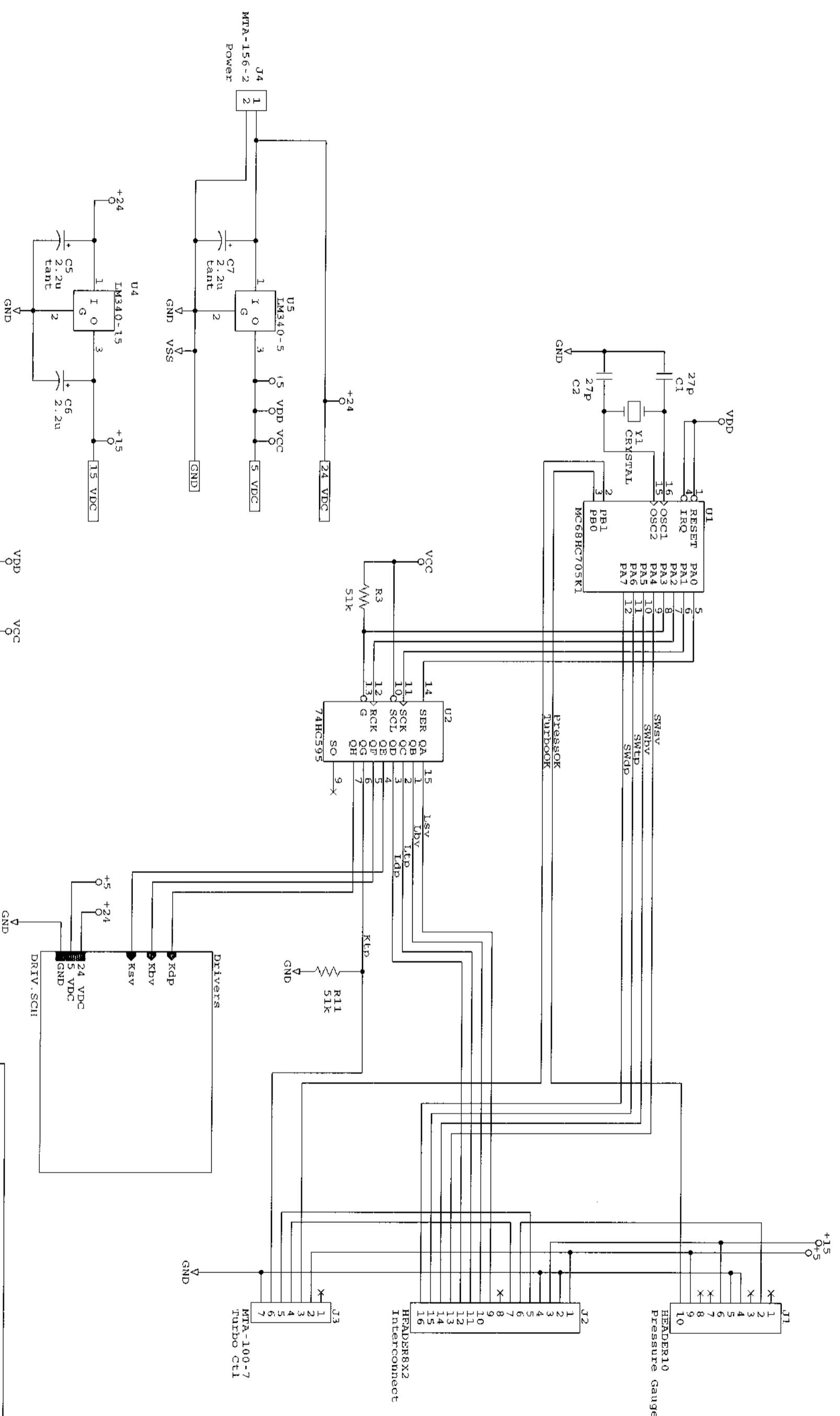

Stanford Research Systems, Inc.	
Title	MCU & Power
Size Document Number	MCA_C1
Date:	December 17, 1996 Sheet 1 of 3
REV	A

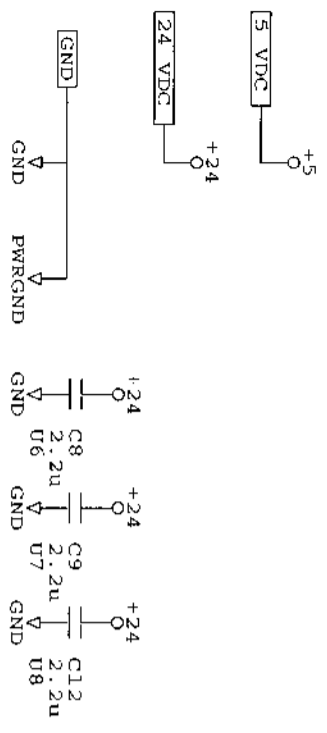
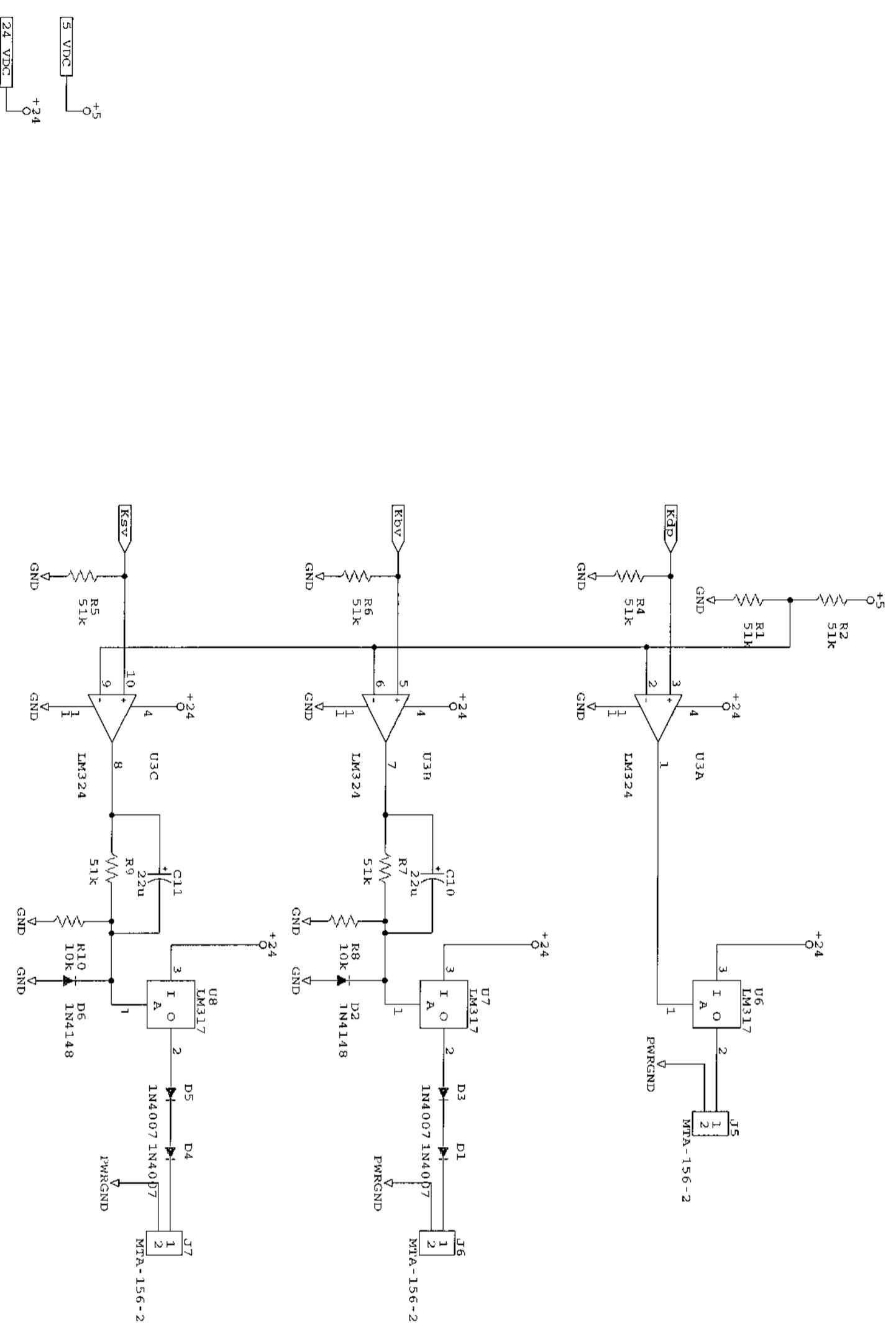

Stanford Research Systems	
Title	
Relay & Solenoid Drivers	
Size	Document Number
B	MCA_C2
Date:	December 17, 1996 Sheet
	2 of 3
REV	A

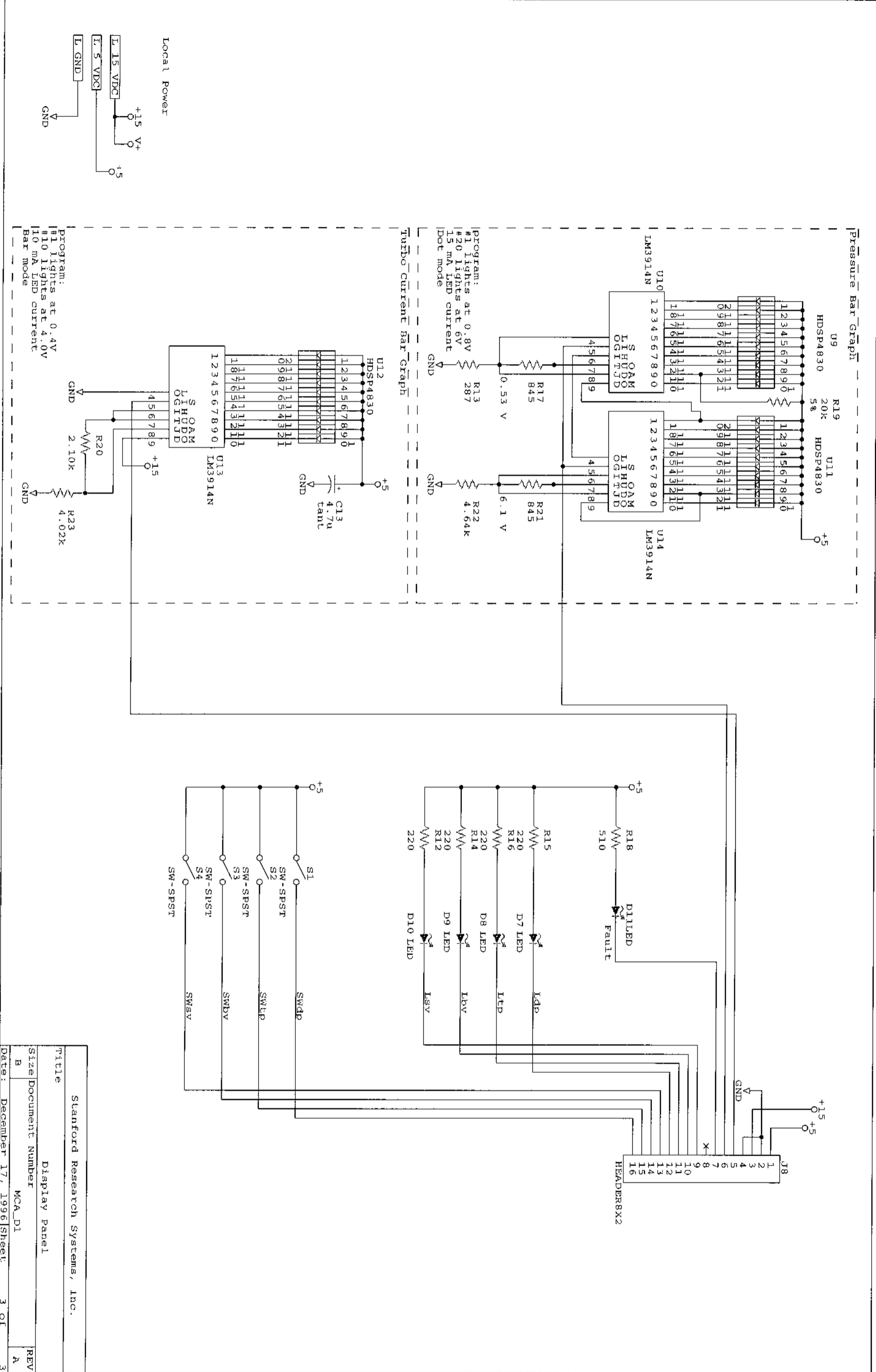

Stanford Research Systems, Inc.	
Title	Display Panel
Size	Document Number
B	MCA_D1
Date:	December 17, 1996
Sheet:	3 of 3
REV	A

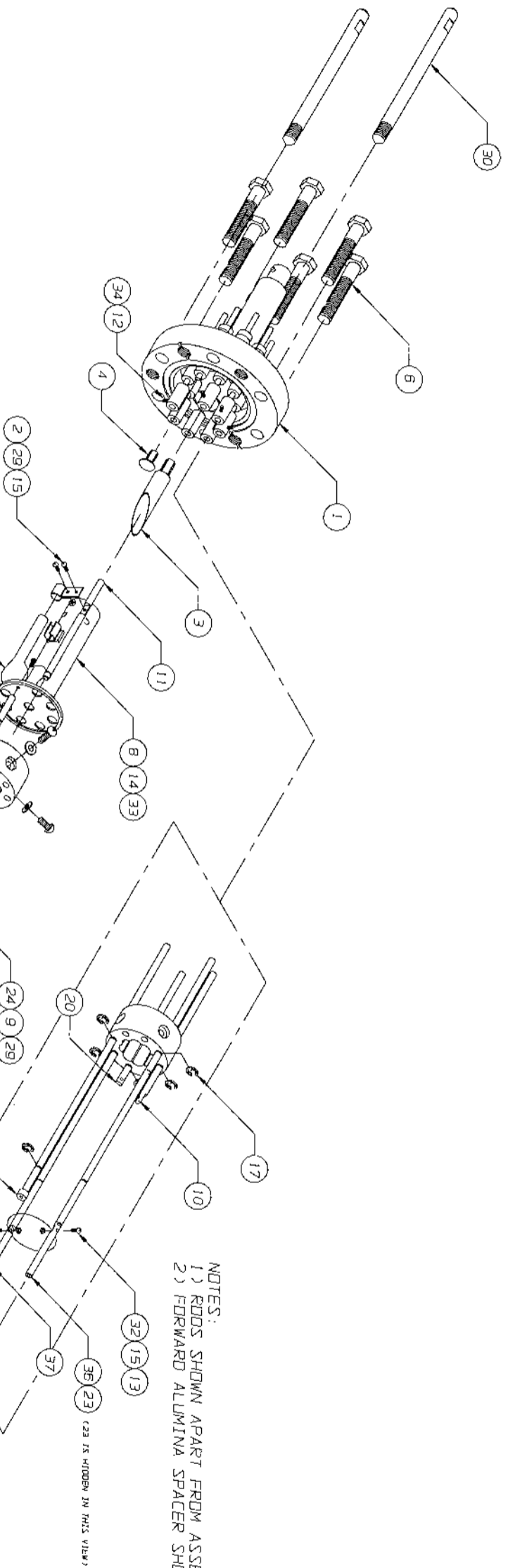

NOTES:
 1) RODS SHOWN APART FROM ASSEMBLY FOR CLARITY
 2) FORWARD ALUMINA SPACER SHOWN FOR REFERENCE

(23 IS HIDDEN IN THIS VIEW)

1	37	7-00600-721	FILAMENT SUPPLY ROD
1	36	7-00599-721	FILAMENT RETURN ROD
1	35	7-00599-721	ANODE ALIGN ROD
5	34	0-00601-024	SET SCREW, 4-40 X 1/15, SS 18-80
4	33	0-00600-000	WASHER, #2, KINAFITURE
1	32	7-00611-720	THOZ-1 ^o FILAMENT
1	31	7-00594-721	CONFLAT NIPPLE
2	30	7-00702-721	ALIGNMENT ROD
4	29	0-00573-024	SCREW, 0-80 X 1/8 PAN SS 18-80
1	28	0-00591-720	ANODE GRID
1	27	7-00592-720	REPELLER CAGE
1	26	7-00597-721	ANODE CONNECT ROD
1	25	7-00590-720	FOCUS PLATE
2	24	7-00593-720	R.F. CONNECTORS
1	23	7-00595-721	FOCUS CONNECT ROD
4	22	7-00587-721	ULTRA PRECISION SHAFT
2	21	7-00531-721	ALUMINA SPACER
1	20	7-00602-721	SHORT RF CONNECT ROD
8	19	0-00578-000	BELLEVILLE SPRING WASHER
8	18	0-00571-021	PERFORATED SCREW, 4-40 X 5/16 PAN PHILLIPS
12	17	0-00579-000	SLOTTED E-C-CLIP
2	16	7-00596-721	FOCUS/EXIT PLATE ALIGN ROD
3	15	0-00575-010	NUT HEX, 0-80
4	14	0-00577-024	SCREW, 2-56 X 1/8 PAN SS 18-80
8	13	0-00574-024	SCREW, 0-80 X 3/16 PAN SS 18-80
2	12	0-00602-024	SET SCREW, 4-40 X 1/3, (FOR #16, 37)
1	11	7-00685-721	CEN W/ CONNETT ROD
1	10	7-00601-721	LONG RF CONNECTOR ROD
4	9	0-00570-021	PERFORATED SCREW, 4-40 X 1/8 PAN PHILLIPS
1	8	7-00681-721	FC SHIELD ASSEMBLY
OPTION	7	8-00648-800	CONTRAD'S DIVIDE ELECTRON MILLIPLEX (CEN)
SET	6	0-00568-025	1/4-28 X 1 3/8 BLTS, NUTS (6 EA)
1	5	0-00569-000	CU GASKET
1	4	7-00682-721	CEN ANODE
1	3	7-00683-721	FARADAY CLIP
1	2	7-00696-720	CODE CLAMP
1	1	7-00603-721	RGA CONFLAT FLANGE

SRS RGA 100/200/300 EXPLODED VIEW
 NOTES:
 1) ITEM (7) IS AN OPTION
 LAST MODIFIED: 5/28/96 BY JG

RGA PROBE ASSEMBLY

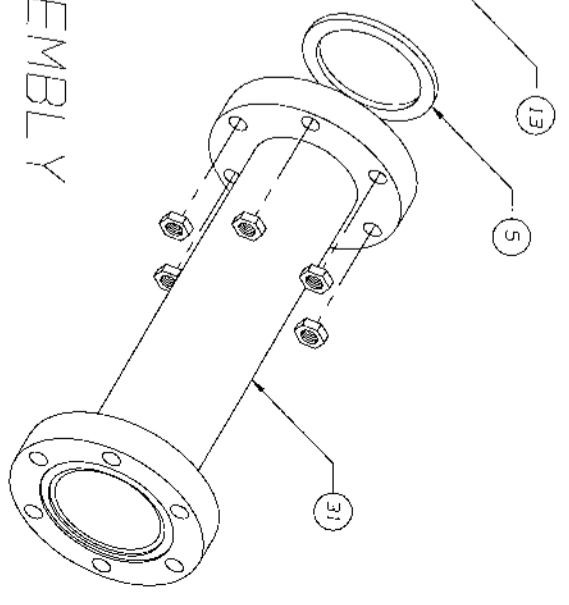

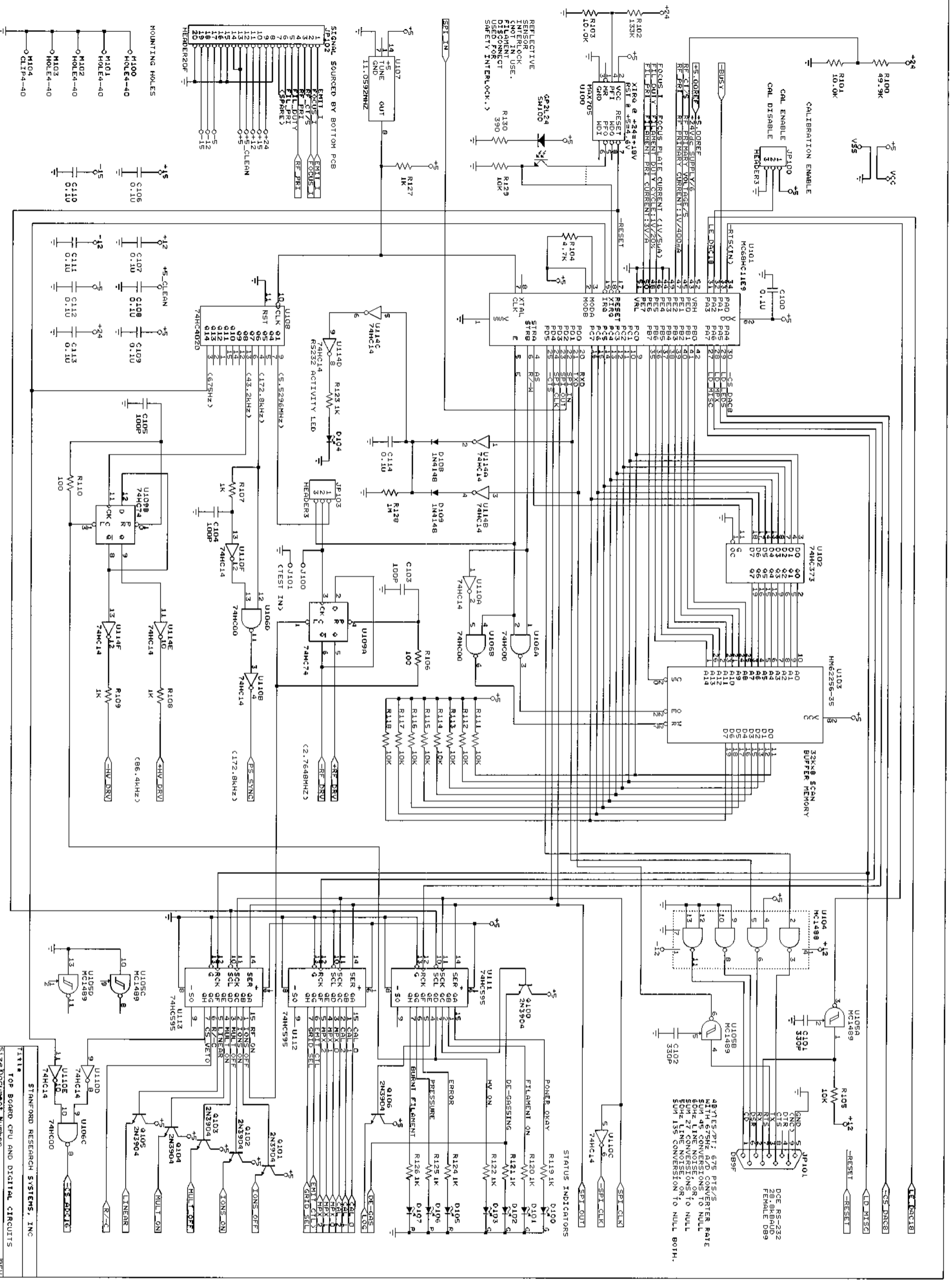

TITLE: STANFORD RESEARCH SYSTEMS, INC.
 TOP BOARD CPU AND DIGITAL CIRCUITS
 Size Document Number: 9MSF-11
 REV: C
 Date: May 3, 1995 Sheet 1 of 8

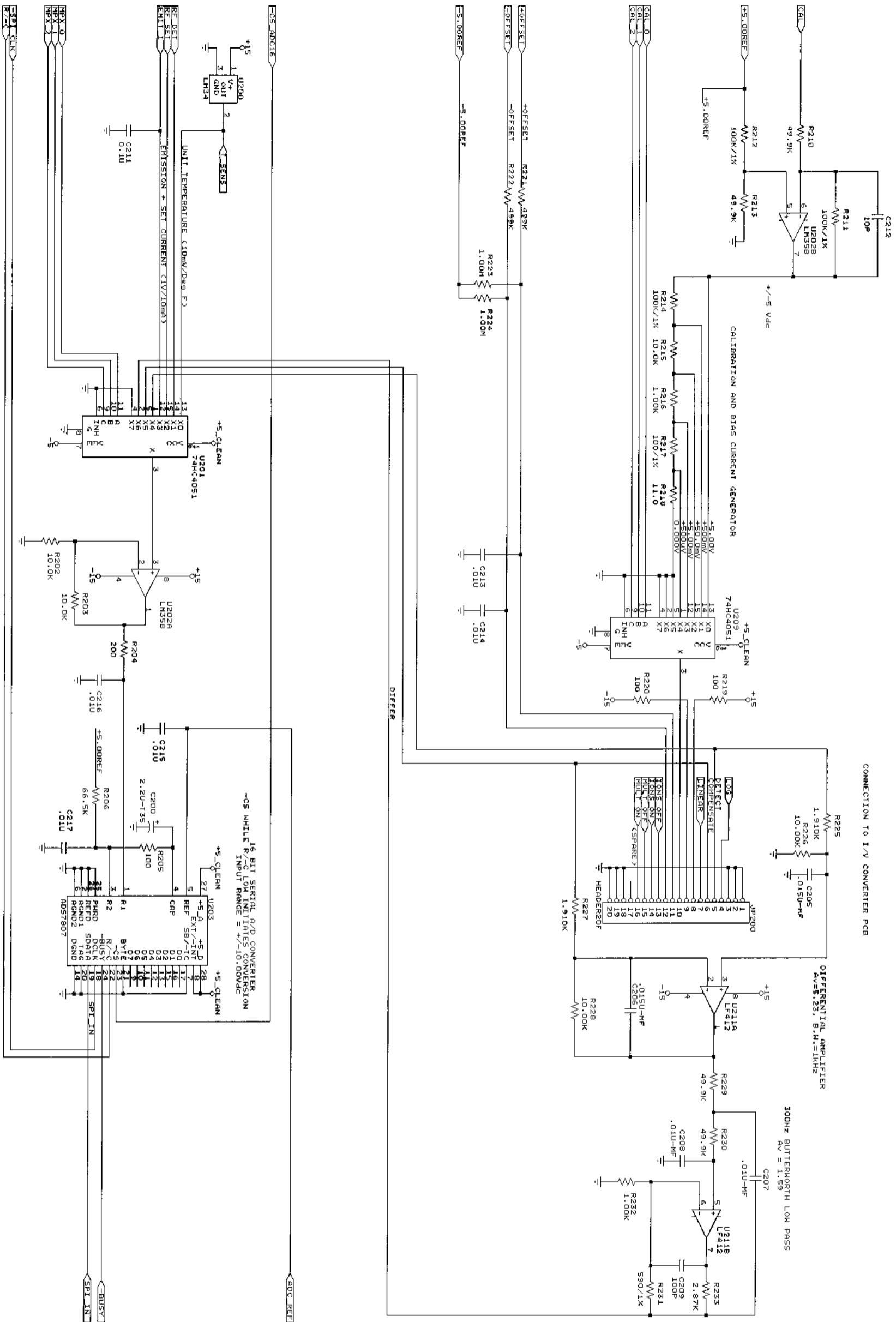

CONNECTION TO I/V CONVERTER PCB

DIFFERENTIAL AMPLIFIER
A_V = 5.25, B.W. = 1KHZ

300Hz BUTTERWORTH LOW PASS
A_V = 1.59

DIFFER

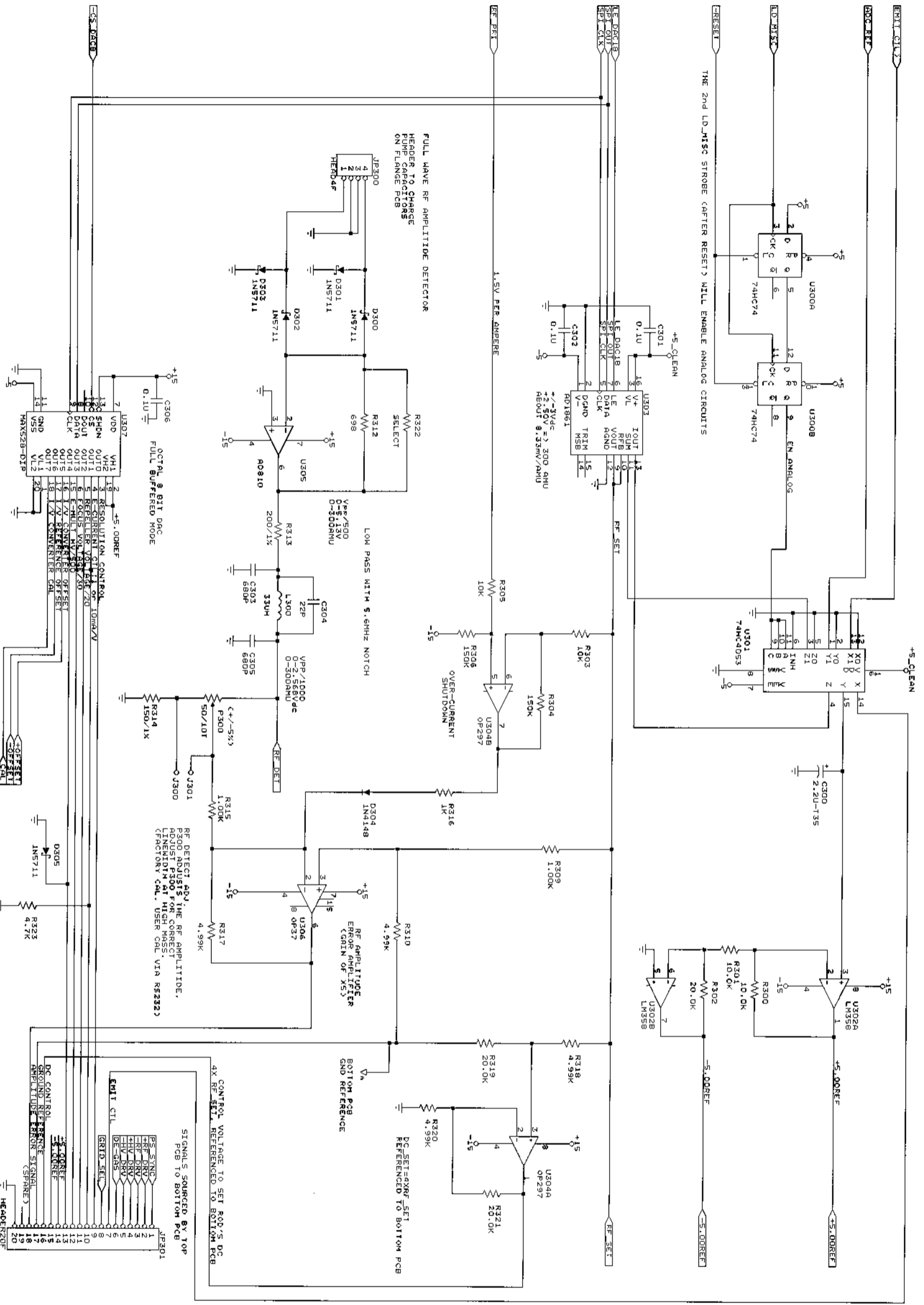

STANFORD RESEARCH SYSTEMS
TOP BOARD RF CONTROL
Size Document Number: 0MSF-13
REV: E
DATE: May 6, 1993
Sheet: 3 of 8

SIGNALS SOURCED BY TOP BOARD

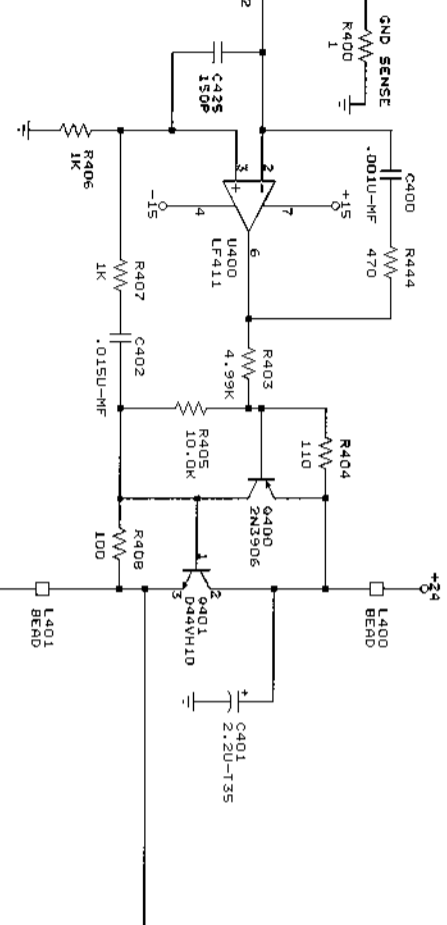
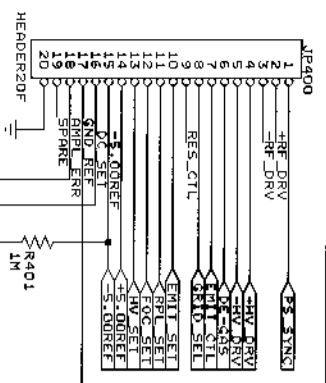

MICROMETALS T130-6 TOROIDAL CORE. EACH 39T SECONDARY HAS ABOUT 2 SECONDARIES BELDEN #85045.

RED INSULATED LEAD J402
BLACK INSULATED LEAD J403
BLACK INSULATED LEAD J404
BLACK INSULATED LEAD J405
BLACK INSULATED LEAD J406
BLACK INSULATED LEAD J407
BLACK INSULATED LEAD J408
BLACK INSULATED LEAD J409
BLACK INSULATED LEAD J410
BLACK INSULATED LEAD J411
BLACK INSULATED LEAD J412
BLACK INSULATED LEAD J413
BLACK INSULATED LEAD J414
BLACK INSULATED LEAD J415
BLACK INSULATED LEAD J416
BLACK INSULATED LEAD J417
BLACK INSULATED LEAD J418
BLACK INSULATED LEAD J419
BLACK INSULATED LEAD J420
BLACK INSULATED LEAD J421
BLACK INSULATED LEAD J422
BLACK INSULATED LEAD J423
BLACK INSULATED LEAD J424
BLACK INSULATED LEAD J425
BLACK INSULATED LEAD J426
BLACK INSULATED LEAD J427
BLACK INSULATED LEAD J428
BLACK INSULATED LEAD J429
BLACK INSULATED LEAD J430
BLACK INSULATED LEAD J431
BLACK INSULATED LEAD J432
BLACK INSULATED LEAD J433
BLACK INSULATED LEAD J434
BLACK INSULATED LEAD J435
BLACK INSULATED LEAD J436
BLACK INSULATED LEAD J437
BLACK INSULATED LEAD J438
BLACK INSULATED LEAD J439
BLACK INSULATED LEAD J440
BLACK INSULATED LEAD J441
BLACK INSULATED LEAD J442
BLACK INSULATED LEAD J443
BLACK INSULATED LEAD J444
BLACK INSULATED LEAD J445
BLACK INSULATED LEAD J446
BLACK INSULATED LEAD J447
BLACK INSULATED LEAD J448
BLACK INSULATED LEAD J449
BLACK INSULATED LEAD J450

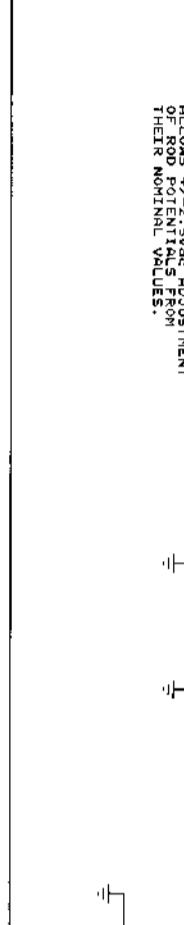
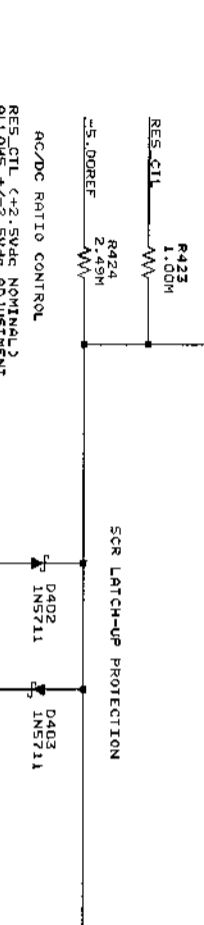
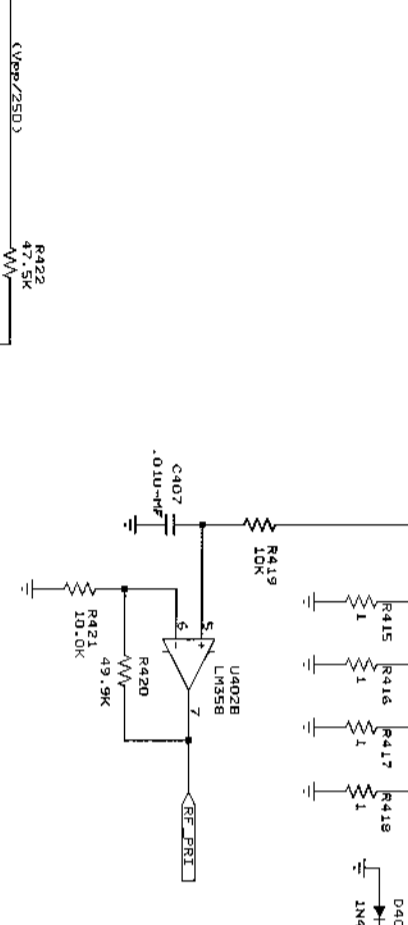
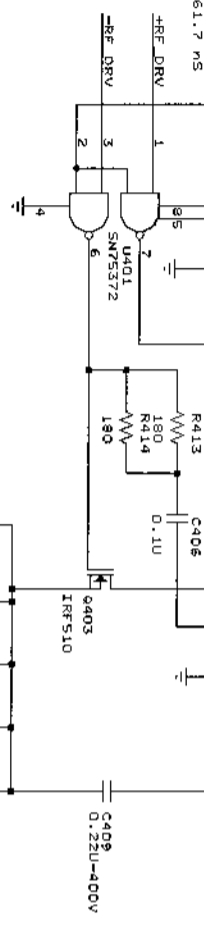

CAUTION: UP TO 256VPP AND UP TO 214Vdc INSULATED LEADS HAVE HIGH RF VOLTAGES AT 180 DEGREES

RED INSULATED LEAD J402
BLACK INSULATED LEAD J403
BLACK INSULATED LEAD J404
BLACK INSULATED LEAD J405
BLACK INSULATED LEAD J406
BLACK INSULATED LEAD J407
BLACK INSULATED LEAD J408
BLACK INSULATED LEAD J409
BLACK INSULATED LEAD J410
BLACK INSULATED LEAD J411
BLACK INSULATED LEAD J412
BLACK INSULATED LEAD J413
BLACK INSULATED LEAD J414
BLACK INSULATED LEAD J415
BLACK INSULATED LEAD J416
BLACK INSULATED LEAD J417
BLACK INSULATED LEAD J418
BLACK INSULATED LEAD J419
BLACK INSULATED LEAD J420
BLACK INSULATED LEAD J421
BLACK INSULATED LEAD J422
BLACK INSULATED LEAD J423
BLACK INSULATED LEAD J424
BLACK INSULATED LEAD J425
BLACK INSULATED LEAD J426
BLACK INSULATED LEAD J427
BLACK INSULATED LEAD J428
BLACK INSULATED LEAD J429
BLACK INSULATED LEAD J430
BLACK INSULATED LEAD J431
BLACK INSULATED LEAD J432
BLACK INSULATED LEAD J433
BLACK INSULATED LEAD J434
BLACK INSULATED LEAD J435
BLACK INSULATED LEAD J436
BLACK INSULATED LEAD J437
BLACK INSULATED LEAD J438
BLACK INSULATED LEAD J439
BLACK INSULATED LEAD J440
BLACK INSULATED LEAD J441
BLACK INSULATED LEAD J442
BLACK INSULATED LEAD J443
BLACK INSULATED LEAD J444
BLACK INSULATED LEAD J445
BLACK INSULATED LEAD J446
BLACK INSULATED LEAD J447
BLACK INSULATED LEAD J448
BLACK INSULATED LEAD J449
BLACK INSULATED LEAD J450

SELECT APPROPRIATE FREQUENCY TO DRIVE FREQUENCY (ABOUT 9KHZ/NF @ 5529.6KHZ) (POLYPROPYLENE/SOVDC)

THE RED-INSIDE AND BLACK-OUTSIDE LEADS HAVE EXTRA INSULATION

WHEN DRIVEN DIFFERENTIALLY, EACH OF ABOUT 50% TO GROUND.

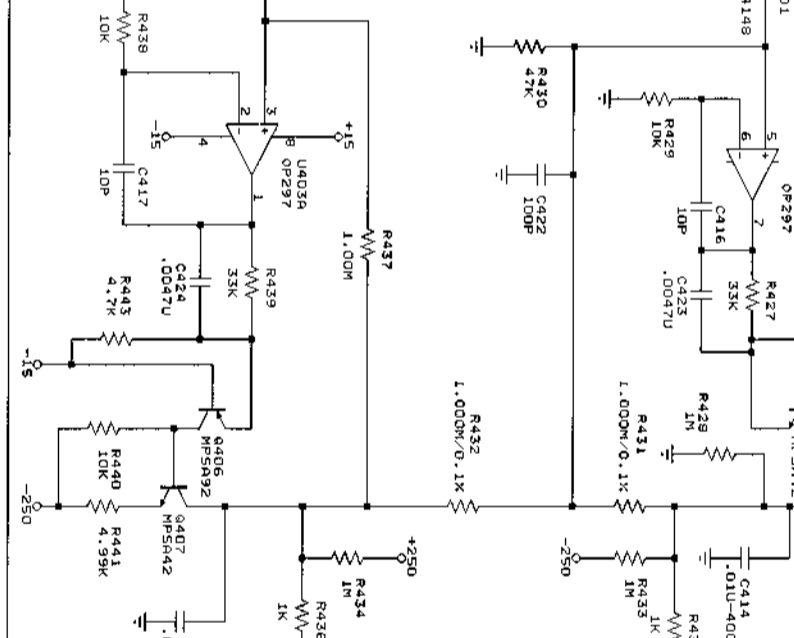

STANFORD RESEARCH SYSTEMS
QUAD RF SUPPLY
Document Number QMSF B1
REV E
Date: 6.13.96 Sheet 4 of 8

DE-GAS

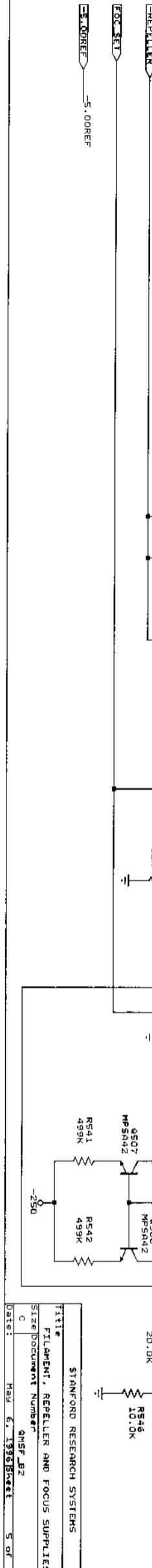
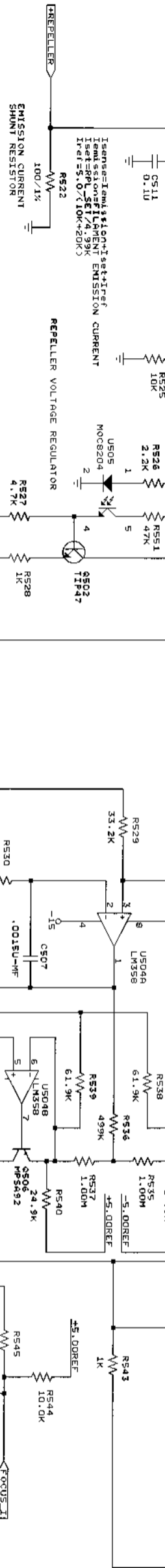
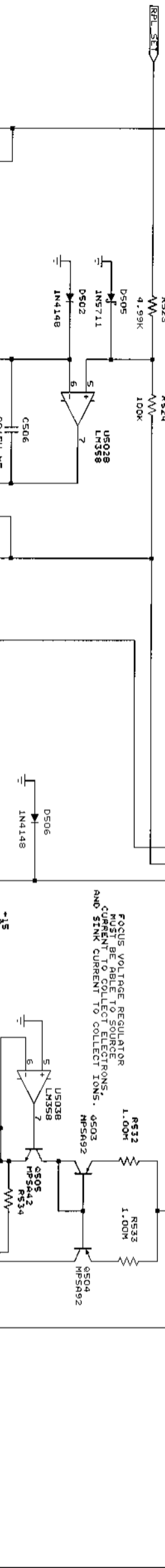
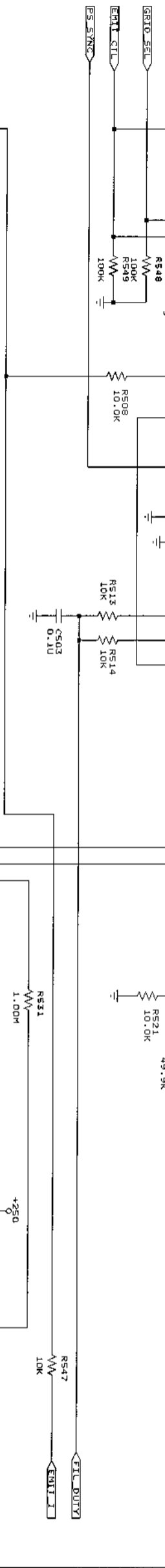
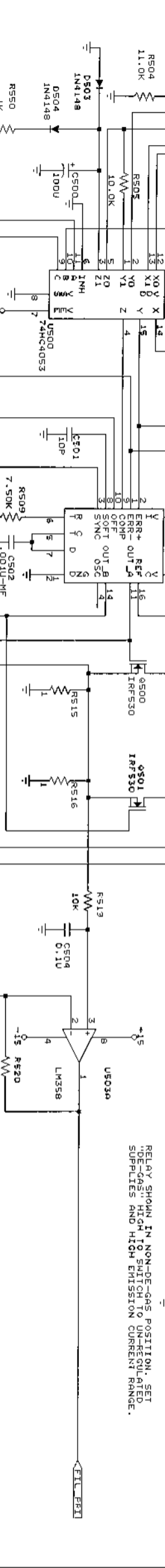
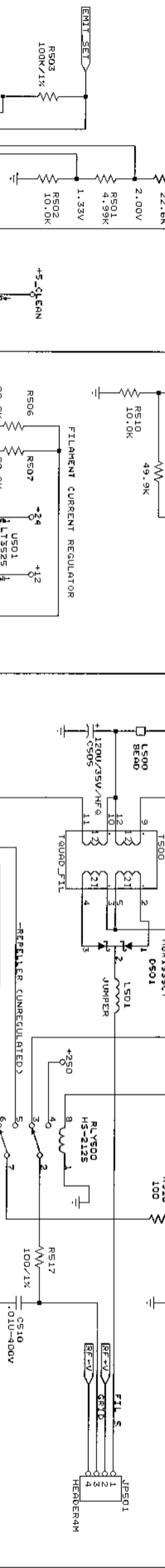
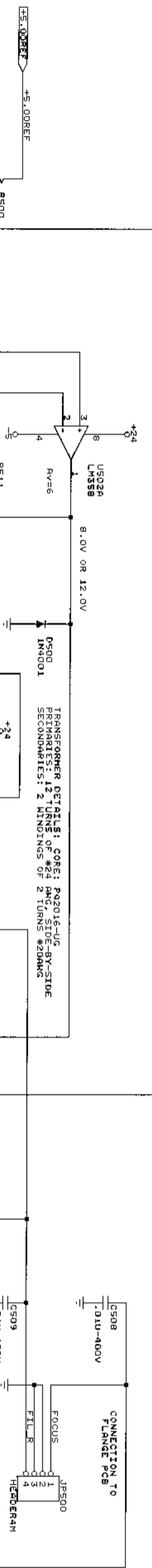

STANFORD RESEARCH SYSTEMS

Title: FILAMENT, REPELLER AND FOCUS SUPPLIES

Size: Document Number: QMSF_B2

REV: E

Date: Mar 6, 1996

Page: 5 of 8

