

NI RMC-8354

User Manual

Worldwide Technical Support and Product Information

ni.com

Worldwide Offices

Visit ni.com/niglobal to access the branch office websites, which provide up-to-date contact information, support phone numbers, email addresses, and current events.

National Instruments Corporate Headquarters

11500 North Mopac Expressway Austin, Texas 78759-3504 USA Tel: 512 683 0100

For further support information, refer to the *NI Services* appendix. To comment on National Instruments documentation, refer to the National Instruments website at ni.com/info and enter the Info Code *feedback*.

© 2010–2014 National Instruments. All rights reserved.

Legal Information

Limited Warranty

This document is provided 'as is' and is subject to being changed, without notice, in future editions. For the latest version, refer to ni.com/manuals. NI reviews this document carefully for technical accuracy; however, NI MAKES NO EXPRESS OR IMPLIED WARRANTIES AS TO THE ACCURACY OF THE INFORMATION CONTAINED HEREIN AND SHALL NOT BE LIABLE FOR ANY ERRORS.

NI warrants that its hardware products will be free of defects in materials and workmanship that cause the product to fail to substantially conform to the applicable NI published specifications for one (1) year from the date of invoice.

For a period of ninety (90) days from the date of invoice, NI warrants that (i) its software products will perform substantially in accordance with the applicable documentation provided with the software and (ii) the software media will be free from defects in materials and workmanship.

If NI receives notice of a defect or non-conformance during the applicable warranty period, NI will, in its discretion: (i) repair or replace the affected product, or (ii) refund the fees paid for the affected product. Repaired or replaced Hardware will be warranted for the remainder of the original warranty period or ninety (90) days, whichever is longer. If NI elects to repair or replace the product, NI may use new or refurbished parts or products that are equivalent to new in performance and reliability and are at least functionally equivalent to the original part or product.

You must obtain an RMA number from NI before returning any product to NI. NI reserves the right to charge a fee for examining and testing Hardware not covered by the Limited Warranty.

This Limited Warranty does not apply if the defect of the product resulted from improper or inadequate maintenance, installation, repair, or calibration (performed by a party other than NI); unauthorized modification; improper environment; use of an improper hardware or software key; improper use or operation outside of the specification for the product; improper voltages; accident, abuse, or neglect; or a hazard such as lightning, flood, or other act of nature.

THE REMEDIES SET FORTH ABOVE ARE EXCLUSIVE AND THE CUSTOMER'S SOLE REMEDIES, AND SHALL APPLY EVEN IF SUCH REMEDIES FAIL OF THEIR ESSENTIAL PURPOSE.

EXCEPT AS EXPRESSLY SET FORTH HEREIN, PRODUCTS ARE PROVIDED "AS IS" WITHOUT WARRANTY OF ANY KIND AND NI DISCLAIMS ALL WARRANTIES, EXPRESSED OR IMPLIED, WITH RESPECT TO THE PRODUCTS, INCLUDING ANY IMPLIED WARRANTIES OF MERCHANTABILITY, FITNESS FOR A PARTICULAR PURPOSE, TITLE OR NON-INFRINGEMENT, AND ANY WARRANTIES THAT MAY ARISE FROM USAGE OF TRADE OR COURSE OF DEALING. NI DOES NOT WARRANT, GUARANTEE, OR MAKE ANY REPRESENTATIONS REGARDING THE USE OF OR THE RESULTS OF THE USE OF THE PRODUCTS IN TERMS OF CORRECTNESS, ACCURACY, RELIABILITY, OR OTHERWISE. NI DOES NOT WARRANT THAT THE OPERATION OF THE PRODUCTS WILL BE UNINTERRUPTED OR ERROR FREE.

In the event that you and NI have a separate signed written agreement with warranty terms covering the products, then the warranty terms in the separate agreement shall control.

Copyright

Under the copyright laws, this publication may not be reproduced or transmitted in any form, electronic or mechanical, including photocopying, recording, storing in an information retrieval system, or translating, in whole or in part, without the prior written consent of National Instruments Corporation.

National Instruments respects the intellectual property of others, and we ask our users to do the same. NI software is protected by copyright and other intellectual property laws. Where NI software may be used to reproduce software or other materials belonging to others, you may use NI software only to reproduce materials that you may reproduce in accordance with the terms of any applicable license or other legal restriction.

End-User License Agreements and Third-Party Legal Notices

You can find end-user license agreements (EULAs) and third-party legal notices in the following locations:

- Notices are located in the <National Instruments>_Legal Information and <National Instruments> directories.
- EULAs are located in the <National Instruments>\Shared\MDF\Legal\license directory.
- Review <National Instruments>_Legal Information.txt for information on including legal information in installers built with NI products.

U.S. Government Restricted Rights

If you are an agency, department, or other entity of the United States Government ("Government"), the use, duplication, reproduction, release, modification, disclosure or transfer of the technical data included in this manual is governed by the Restricted Rights provisions under Federal Acquisition Regulation 52 227-14 for civilian agencies and Defense Federal Acquisition Regulation Supplement Section 252 227-7014 and 252 227-7015 for military agencies.

Trademarks

Refer to the *NI Trademarks and Logo Guidelines* at ni.com/trademarks for more information on National Instruments trademarks.

ARM, Keil, and μ Vision are trademarks or registered of ARM Ltd or its subsidiaries.

LEGO, the LEGO logo, WEDO, and MINDSTORMS are trademarks of the LEGO Group.

TETRIX by Pitsco is a trademark of Pitsco, Inc.

FIELDBUS FOUNDATION™ and FOUNDATION™ are trademarks of the Fieldbus Foundation.

EtherCAT® is a registered trademark of and licensed by Beckhoff Automation GmbH

CANopen® is a registered Community Trademark of CAN in Automation e V

DeviceNet™ and EtherNet/IP™ are trademarks of ODVA

Go!, SensorDAQ, and Vernier are registered trademarks of Vernier Software & Technology Vernier Software & Technology and vernier.com are trademarks or trade dress

Xilinx is the registered trademark of Xilinx, Inc

Taprite and Trilobular are registered trademarks of Research Engineering & Manufacturing Inc

FireWire® is the registered trademark of Apple Inc

Linux® is the registered trademark of Linus Torvalds in the U S and other countries

Handle Graphics®, MATLAB®, Real-Time Workshop®, Simulink®, Stateflow®, and xPC TargetBox® are registered trademarks, and TargetBox™ and Target Language Compiler™ are trademarks of The MathWorks, Inc

Tektronix®, Tek, and Tektronix, Enabling Technology are registered trademarks of Tektronix, Inc

The Bluetooth® word mark is a registered trademark owned by the Bluetooth SIG, Inc

The ExpressCard™ word mark and logos are owned by PCMCIA and any use of such marks by National Instruments is under license

The mark LabWindows is used under a license from Microsoft Corporation Windows is a registered trademark of Microsoft Corporation in the United States and other countries

Other product and company names mentioned herein are trademarks or trade names of their respective companies

Members of the National Instruments Alliance Partner Program are business entities independent from National Instruments and have no agency, partnership, or joint-venture relationship with National Instruments

Patents

For patents covering National Instruments products/technology, refer to the appropriate location: **Help»Patents** in your software, the `patents.txt` file on your media, or the *National Instruments Patent Notice* at ni.com/patents

Export Compliance Information

Refer to the *Export Compliance Information* at ni.com/legal/export-compliance for the National Instruments global trade compliance policy and how to obtain relevant HTS codes, ECCNs, and other import/export data

WARNING REGARDING USE OF NATIONAL INSTRUMENTS PRODUCTS

YOU ARE ULTIMATELY RESPONSIBLE FOR VERIFYING AND VALIDATING THE SUITABILITY AND RELIABILITY OF THE PRODUCTS WHENEVER THE PRODUCTS ARE INCORPORATED IN YOUR SYSTEM OR APPLICATION, INCLUDING THE APPROPRIATE DESIGN, PROCESS, AND SAFETY LEVEL OF SUCH SYSTEM OR APPLICATION

PRODUCTS ARE NOT DESIGNED, MANUFACTURED, OR TESTED FOR USE IN LIFE OR SAFETY CRITICAL SYSTEMS, HAZARDOUS ENVIRONMENTS OR ANY OTHER ENVIRONMENTS REQUIRING FAIL-SAFE PERFORMANCE, INCLUDING IN THE OPERATION OF NUCLEAR FACILITIES; AIRCRAFT NAVIGATION; AIR TRAFFIC CONTROL SYSTEMS; LIFE SAVING OR LIFE SUSTAINING SYSTEMS OR SUCH OTHER MEDICAL DEVICES; OR ANY OTHER APPLICATION IN WHICH THE FAILURE OF THE PRODUCT OR SERVICE COULD LEAD TO DEATH, PERSONAL INJURY, SEVERE PROPERTY DAMAGE OR ENVIRONMENTAL HARM (COLLECTIVELY, "HIGH-RISK USES") FURTHER, PRUDENT STEPS MUST BE TAKEN TO PROTECT AGAINST FAILURES, INCLUDING PROVIDING BACK-UP AND SHUT-DOWN MECHANISMS NI EXPRESSLY DISCLAIMS ANY EXPRESS OR IMPLIED WARRANTY OF FITNESS OF THE PRODUCTS OR SERVICES FOR HIGH-RISK USES

Compliance

Electromagnetic Compatibility Information

This hardware has been tested and found to comply with the applicable regulatory requirements and limits for electromagnetic compatibility (EMC) as indicated in the hardware's Declaration of Conformity (DoC)¹. These requirements and limits are designed to provide reasonable protection against harmful interference when the hardware is operated in the intended electromagnetic environment. In special cases, for example when either highly sensitive or noisy hardware is being used in close proximity, additional mitigation measures may have to be employed to minimize the potential for electromagnetic interference.

While this hardware is compliant with the applicable regulatory EMC requirements, there is no guarantee that interference will not occur in a particular installation. To minimize the potential for the hardware to cause interference to radio and television reception or to experience unacceptable performance degradation, install and use this hardware in strict accordance with the instructions in the hardware documentation and the DoC¹.

If this hardware does cause interference with licensed radio communications services or other nearby electronics, which can be determined by turning the hardware off and on, you are encouraged to try to correct the interference by one or more of the following measures:

- Reorient the antenna of the receiver (the device suffering interference).
- Relocate the transmitter (the device generating interference) with respect to the receiver.
- Plug the transmitter into a different outlet so that the transmitter and the receiver are on different branch circuits.

Some hardware may require the use of a metal, shielded enclosure (windowless version) to meet the EMC requirements for special EMC environments such as, for marine use or in heavy industrial areas. Refer to the hardware's user documentation and the DoC¹ for product installation requirements.

When the hardware is connected to a test object or to test leads, the system may become more sensitive to disturbances or may cause interference in the local electromagnetic environment.

Operation of this hardware in a residential area is likely to cause harmful interference. Users are required to correct the interference at their own expense or cease operation of the hardware.

Changes or modifications not expressly approved by National Instruments could void the user's right to operate the hardware under the local regulatory rules.

¹ The Declaration of Conformity (DoC) contains important EMC compliance information and instructions for the user or installer. To obtain the DoC for this product, visit ni.com/certification, search by model number or product line, and click the appropriate link in the Certification column.

Contents

About This Manual

Related Documentation	xi
-----------------------------	----

Chapter 1

Getting Started

Unpacking.....	1-1
What You Need to Get Started.....	1-1
NI RMC-8354 Overview.....	1-2
Key Features.....	1-2
Mainboard Features.....	1-2
CPU.....	1-2
Chipset.....	1-2
Memory.....	1-2
Slots.....	1-3
Video.....	1-3
HDD.....	1-3
DVD-ROM.....	1-3
Onboard LAN.....	1-3
Onboard I/O.....	1-3
Power Management Features.....	1-3
Front Panel LEDs.....	1-3
System Management.....	1-4
NI RMC-8354 Description.....	1-4
Optional Equipment.....	1-5
Memory Upgrades.....	1-5
USB Floppy Disk Drive.....	1-5
National Instruments Software.....	1-5

Chapter 2

Installation and BIOS Setup

Safety Information.....	2-1
Chassis Cooling Considerations.....	2-2
Providing Adequate Clearance.....	2-2
Installation.....	2-2
Connecting Safety Ground.....	2-3
Connecting to Power Source.....	2-3
BIOS Setup.....	2-3
Main BIOS Setup Menu.....	2-4
Advanced Setup Configurations.....	2-4
Boot Feature.....	2-4
Processor and Clock Options.....	2-5
Advanced Chipset Control.....	2-7

SATA/Floppy Configuration	2-8
PCI/PnP Configuration	2-10
Super IO Device Configuration	2-12
Remote Access Configuration	2-12
Hardware Health Configuration.....	2-13
ACPI Configuration.....	2-15
Event Log Configuration	2-16
Security Settings	2-16
Supervisor Password.....	2-16
User Password.....	2-16
Change Supervisor Password.....	2-16
User Access Level	2-17
Change User Password	2-17
Clear User Password.....	2-17
Password Check	2-17
Boot Sector Virus Protection	2-17
Boot Settings	2-17
Boot Device Priority	2-17
Hard Disk Drives	2-17
Removable Drives.....	2-18
Retry Boot Devices	2-18
Exit Options	2-18
Save Changes and Exit	2-18
Discard Changes and Exit.....	2-18
Discard Changes	2-18
Load Optimal Defaults.....	2-18
Load Fail-Safe Defaults.....	2-18
POST Error Beep Codes	2-18
Recoverable POST Error Beep Codes	2-19
Rack Mounting	2-19
Installing the Inner Slides	2-20
Assembling the Outer Slide Assemblies.....	2-21
Installing the Outer Slide Assemblies in the Rack	2-22
Installing the Chassis into the Rack	2-23
OS Reinstallation and Recovery	2-25
Cleaning.....	2-26
Exterior Cleaning.....	2-26

Chapter 3

I/O Information

Rear Panel Connectors.....	3-1
PS/2.....	3-2
Universal Serial Bus	3-3
Serial.....	3-4
VGA.....	3-4
Ethernet.....	3-6
MXI-Express Connectors	3-7

Chapter 4

Common Configuration Questions

General Questions.....	4-1
Boot Options.....	4-2
Chassis Configuration.....	4-2
Upgrade Information	4-3

Chapter 5

Troubleshooting

Appendix A

Specifications

Appendix B

Hardware Configuration

Appendix C

Intel SATA RAID Utility for Intel ICH10R

Appendix D

NI Services

Glossary

Index

About This Manual

The *User Manual* contains information about installing, configuring, using, and maintaining the NI RMC-8354.

Related Documentation

The following documents contain information that you may find helpful as you read this manual:

- *CompactPCI Specification PICMG 2.0 R 3.0*
- *PXI Hardware Specification, Revision 2.1*
- *PXI Software Specification, Revision 2.1*
- ANSI/IEEE Standard 1014-1987, *IEEE Standard for a Versatile Backplane Bus: VMEbus*
- ANSI/VITA 1-1994, *VME64*
- *NI-VISA User Manual*
- *NI-VISA Programmer Reference Manual*
- *Read Me First: Safety and Electromagnetic Compatibility*, National Instruments

Getting Started

This chapter describes the key features of the NI RMC-8354 and lists the kit contents and optional equipment you can order from National Instruments.

Unpacking

Carefully inspect the shipping container and the NI RMC-8354 for damage. Check for visible damage to the metal work. Check to make sure all hardware and switches are undamaged. If damage appears to have been caused during shipment, file a claim with the carrier. Retain the packing material for possible inspection and/or reshipment.

What You Need to Get Started

The NI RMC-8354 kit contains the following items:

- NI RMC-8354 rack mount controller
- NI RMC-8354 User Manual*
- Windows recovery CD/DVD
- Rack mount kit
- Front bezel
- AC power cable (refer to Table 1-1 for a list of AC power cables)

Table 1-1. AC Power Cables

Power Cable	Reference Standards
Standard 120 V (USA)	ANSI C73.11/NEMA 5-15-P/IEC83
Switzerland 220 V	SEV
Australia 240 V	AS C112
Universal Euro 230 V	CEE (7), II, IV, VII IEC83
North America 240 V	ANSI C73.20/NEMA 6-15-P/IEC83
United Kingdom 230 V	BS 1363/IEC83
Japan 100 V	ANSI C73.11/NEMA 5-15-P/IEC83

The unit comes with the standard 120 V (USA) cable. If you have the incorrect AC power cable, contact National Instruments.

NI RMC-8354 Overview

The NI RMC-8354 is a 1U PC-server-based controller for remote control of PXI chassis. The controller provides leading-edge processing power with Intel Core i7 Quad Core processors, high disk bandwidth with hardware RAID support, high I/O bandwidth with a PCI Express 2.0 x16 slot, and up to 16 GB of memory.

Key Features

The NI RMC-8354 offers the performance of a high-end PC in a compact 1U rack-mountable form factor for controlling a PXI or PXI Express system using a National Instruments remote controller.

Mainboard Features

CPU

- Intel Core i7-860 Quad Core 2.8 GHz, 8 MB Cache, LGA1156

Chipset

- Intel 3420 chipset

Memory

- 1/2 GB DDR3 memory standard (1/2 × 1 GB)
- Maximum memory supported: 16 GB DDR3-1333 in 4 DIMM sockets

Slots

- One PCI Express 2.0 x16 slot

Video

- Matrox G200eW 16 MB DDR2 (max resolution 1280 × 1024)

HDD

- 1 × 500 GB or 4 × 500 GB SATA (3 Gbps) hard drive JBOD/RAID5

DVD-ROM

- Slim DVD-ROM drive

Onboard LAN

- 2 × Intel 82574L Gigabit Ethernet controller

Onboard I/O

- PS/2 keyboard port
- PS/2 mouse port
- Serial port
- VGA port
- Two USB 2.0 ports (rear)
- Two USB 2.0 ports (front)
- Two RJ-45 ports

Power Management Features

- ACPI/ACPM power management
- Main switch override mechanism
- Wake-On-LAN (WOL) header
- Wake up on keyboard/mouse from Soft-Off
- Power-on mode from AC power recovery
- Internal/external modem ring-on

Front Panel LEDs

- Power indicator
- LAN status indicators
- HDD indicator
- System temp (overheat) and fan (fail) warning indicator

System Management

- Monitoring for CPU and chassis environment
- CPU thermal trip support
- +5 V standby alert LED
- Fan speed control

NI RMC-8354 Description

Figure 1-1 shows the key features of the NI RMC-8354 front panel. For detailed information about the NI RMC-8354 rear panel, refer to Chapter 3, *I/O Information*.

Figure 1-1. Front View of the NI RMC-8354

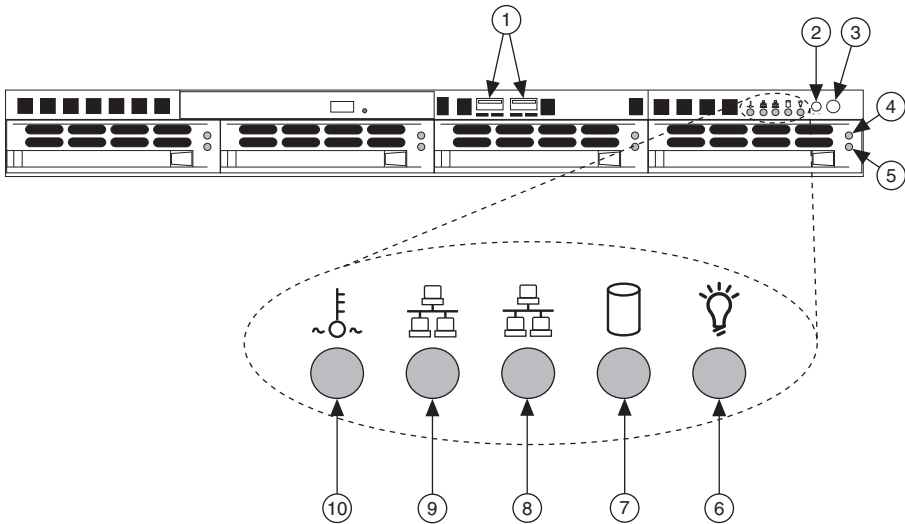

1	USB Ports	6	Power Indicator
2	Reset Switch	7	HDD Indicator
3	Power Switch	8	LAN1 Status Indicator
4	Hard Drive Activity Indicator	9	LAN2 Status Indicator
5	Hard Drive Error Indicator	10	System Temp and Fan Warning Indicator

The front panel includes the following LEDs:

- **Power indicator**—glows when the NI RMC-8354 is powered on.
- **LAN status indicators**—flash when there is activity on LAN1 or LAN2.
- **Overheat/FanFail LED**
 - Off—Normal
 - On—Overheat
 - Flashing—Fan failure warning

Optional Equipment

Memory Upgrades

You can upgrade the NI RMC-8354 memory to a maximum of 16 GB.



Note A 32-bit operating system such as Windows XP Pro addresses a maximum of 4 GB.

The NI RMC-8354 supports dual-channel DDR-3 SDRAM unbuffered memory in four 240-pin DIMM sockets. The NI RMC-8354 is compatible with ECC memory.



Note Supported DIMM sizes are 1 GB, 2 GB, and 4 GB.



Note National Instruments has tested and verified that the DDR-3 DIMMs we sell work with the NI RMC-8354. We recommend you purchase your DDR-3 DIMM modules from National Instruments. Other off-the-shelf DDR-3 DIMM modules are not guaranteed to work properly.

USB Floppy Disk Drive

A USB floppy drive is available from National Instruments, part number 778492-02.

National Instruments Software

National Instruments hardware and software work together to help you make the most of your PXI Express system. The LabVIEW, Measurement Studio, and LabWindows™/CVI™ application development environments combine with leading hardware drivers such as NI-DAQmx to provide exceptional control of NI hardware. Instrument drivers are available at ni.com/idnet to simplify communication with instruments over a variety of buses.

LabVIEW is a powerful and easy-to-use graphical programming environment you can use to acquire data from thousands of different instruments including USB, IEEE 488.2, VXI, serial, PLCs, and plug-in boards. LabVIEW helps you convert acquired data into meaningful results using powerful data analysis routines. Add-on tools provide additional specialized functionality. For more information, visit ni.com/labview and ni.com/toolkits.

If you prefer to use Microsoft's Visual Basic, Visual C++, and Visual Studio .NET for the core of your application, Measurement Studio adds tools for measurement and automation to each language. For more information, visit ni.com/mstudio.

LabWindows/CVI is an interactive ANSI C programming environment designed for building virtual instrument applications. LabWindows/CVI includes a drag-and-drop editor for building user interfaces, a complete ANSI C environment for building your test program logic, and a collection of automated code generation tools, as well as utilities for building automated test

systems, monitoring applications, or laboratory experiments. For more information, visit ni.com/lwcvci.

NI-DAQmx provides an extensive library of functions you can call from your application development environment or interactive environment, such as NI Signal Express. These functions provide an intuitive API for National Instruments multifunction DAQ products. Features include analog input (A/D conversion), buffered data acquisition (high-speed A/D conversion), analog output (D/A conversion), waveform generation, digital I/O, counter/timer operations, SCXI signal conditioning, RTSI or PXI synchronization, self-calibration, messaging, and acquiring data to extended memory. For more information, visit ni.com/daq.

National Instruments modular instruments use specialized drivers suited to each product's specialization. Express VIs provide customized, interactive programming of instruments in a single interface, and soft front panels provide an interface for testing the functionality of each instrument with no programming required. NI switches, DMMs, high-speed DIO, high-speed digitizers, and sources each have customized drivers for high-end modular instrumentation systems. RF applications leverage two drivers, NI-RFSG and NI-RFSA, and dynamic signal acquisition is available through NI-DAQmx. For more information, visit ni.com/modularinstruments.

You can expand the timing and triggering functionality of your PXI system with PXI timing and synchronization products. These products provide precision clock sources, custom routing of triggers for multichassis synchronization, clock sharing, and more, and are programmed with NI-Sync. For more information, visit ni.com/pxi.

NI-VISA is the National Instruments implementation of the VISA specification. VISA is a uniform API for communicating and controlling USB, Serial, GPIB, PXI, VXI, and various other types of instruments. This API aids in the creation of portable applications and instrument drivers. For information about writing your own PXI instrument driver with NI-VISA, refer to the *NI-VISA Help* and the `readme.txt` file in the NI-VISA directory. For more information, visit ni.com/visa.

Installation and BIOS Setup

This chapter describes how to install, configure, and use the NI RMC-8354.

Before connecting the NI RMC-8354 to a power source, read this chapter and the *Read Me First: Safety and Electromagnetic Compatibility* document included with your NI RMC-8354.

Safety Information



Caution Before undertaking any troubleshooting, maintenance, or exploratory procedure, carefully read the following caution notices.



Caution Overloading the circuits may damage supply wiring. Do not exceed the ratings on the equipment nameplate when connecting equipment to the supply circuit.



Caution Risk of explosion if battery is replaced by an incorrect type. Dispose of used batteries according to instructions.

This equipment contains voltage hazardous to human life and safety, and is capable of inflicting personal injury.

- **Chassis Grounding**—The NI RMC-8354 requires a connection from the premise wire safety ground to the NI RMC-8354 chassis ground. The earth safety ground *must* be connected during use of this equipment to minimize shock hazards. Refer to the [Connecting Safety Ground](#) section for instructions on connecting safety ground.
- **Live Circuits**—Operating personnel and service personnel must *not* remove protective covers when operating or servicing the NI RMC-8354. Adjustments and service to internal components must be undertaken by qualified service technicians. During service of this product, the mains connector to the premise wiring must be disconnected. Dangerous voltages may be present under certain conditions; use extreme caution.
- **Explosive Atmosphere**—Do *not* operate the chassis in conditions where flammable gases are present. Under such conditions, this equipment is unsafe and may ignite the gases or gas fumes.
- **Parts Replacement**—Service this equipment only with parts that are exact replacements, both electrically and mechanically. Contact National Instruments for replacement part information. Installation of parts with those that are not direct replacements may cause harm to personnel operating the chassis. Furthermore, damage or fire may occur if replacement parts are unsuitable.
- **Modification**—Do *not* modify any part of the NI RMC-8354 from its original condition. Unsuitable modifications may result in safety hazards.

Chassis Cooling Considerations

The NI RMC-8354 is designed to operate in an instrument rack. Follow the appropriate installation instructions.



Caution If installed in a closed or multiunit rack assembly, the rack environment operating ambient temperature may be greater than room ambient temperature. Therefore, install the equipment in an environment compatible with the maximum ambient operating temperature (T_{ma}) specified in Appendix A, *Specifications*.

Providing Adequate Clearance

Apertures in the front, top, rear, and along both sides of the chassis facilitate power supply and motherboard cooling. Air enters through the front and top inlets of the chassis and exits through the fans on the rear of the chassis. Place the NI RMC-8354 in an instrument rack so that the fans (air outlets) and the air inlet apertures along the top and front of the chassis have adequate ventilation. Keep other equipment a minimum of 76.2 mm (3 in.) away from the air outlets on the rear of the chassis.

Installation

Follow these steps to connect devices to the NI RMC-8354:



Caution Because of the risk of high energy (>240VA), the unit must be installed only in a Restricted Access Location.

1. Connect a keyboard and mouse to the appropriate connectors on the NI RMC-8354 rear panel.
2. Connect the VGA monitor video cable to the VGA connector on the rear panel.
3. (Optional) To boot into LabVIEW RT, connect the network cable to LAN jack 1 on the rear panel. (Refer to Figure 3-1, *NI RMC-8354 Rear Panel Layout*, for the location of LAN jack 1.)
4. Connect the USB, serial, and parallel devices as necessary to the NI RMC-8354 front and rear panel ports.



Caution To minimize shock hazard, make sure the electrical power outlet you use to power the NI RMC-8354 has an appropriate earth safety ground. Refer to the *Connecting Safety Ground* section for more information.

5. Connect the AC power cable to the AC inlet on the rear panel and to an AC power outlet. For more information, refer to the *Connecting to Power Source* section.
6. Power on the NI RMC-8354.
7. Verify that the NI RMC-8354 boots. If it does not boot, refer to the *What if the NI RMC-8354 does not boot?* section of Chapter 5, *Troubleshooting*.

Connecting Safety Ground

The NI RMC-8354 is designed with a three-position NEMA 5-15 style plug for the U.S. that connects the ground line to the chassis ground. To minimize shock hazard, make sure the electrical power outlet you use to power the chassis has an appropriate earth safety ground.

Connecting to Power Source

Attach input power through the rear AC inlet using the appropriate AC power cable supplied.



Caution Overloading the circuits may damage supply wiring. Do not exceed the ratings on the equipment nameplate when connecting equipment to the supply circuit.



Caution To completely remove power, you *must* disconnect the AC power cable.

The power switch allows you to power on the chassis or place it in standby mode. Push the power switch to the On position (if not already on). Observe that all fans become operational and the power indicator is lit.

BIOS Setup

This section describes all main BIOS setup options.

To enter the BIOS menu, press . Use the up and down arrow keys to move among the different settings in each menu. Use the left and right arrow keys to change the options for each setting.

Press <Esc> to exit the CMOS setup menu. The next section describes in detail how to navigate through the menus.

To access submenus, highlight a menu item and press <Enter>.



Note To reset the BIOS to the default settings, load the optimal defaults by pressing <F9> in the BIOS Setup Utility. Optimal default settings default to the following:

- Disable the floppy controller
- Disable serial port 2 (COM2)
- Enable RAID (Intel)
- Set the fan speed control modes to balanced
- Enable Intel C-STATE tech
- Disable Remote Access configuration

Main BIOS Setup Menu

The main BIOS setup menu includes the following items:

- Device name: Supermicro X8SIE/X8SIE-F/X8SIE-LN4/X8SI6-F
- Version
- Build date
- Processor

The AMI BIOS automatically displays the following processor status items:

- Type of processor
- Speed
- Physical count
- Logical count

- System memory

The system memory displays the following memory sizes available in the system:

- Populated size
- Available size

Advanced Setup Configurations

Use the arrow keys to select **Boot Setup** and press <Enter> to access the submenu items.

Boot Feature

This menu includes the following options.

Quick Boot

If enabled, this option skips certain tests during POST to reduce the time needed for system boot. The options are **Enabled** and **Disabled**.

Quiet Boot

Use this option to modify the bootup screen options between POST messages or the OEM logo. Select **Disabled** to display the POST messages. Select **Enabled** to display the OEM logo instead of the normal POST messages. The options are **Enabled** and **Disabled**.

AddOn ROM Display Mode

This option sets the option ROM display mode. The options are **Force BIOS** and **Keep Current**.

Bootup Num-Lock

This option selects the numlock key power-on state. The options are **Off** and **On**.

PS/2 Mouse Support

This option enables support for the PS/2 mouse. The options are **Disabled**, **Enabled**, and **Auto**.

Wait For “F1” If Error

This option forces the system to wait until <F1> is pressed if an error occurs. The options are **Disabled** and **Enabled**.

Hit “Del” Message Display

This option displays **Press DEL to run Setup** during POST. The options are **Enabled** and **Disabled**.

Watch Dog Function

If enabled, the watch dog timer allows the system to reboot when it is inactive for more than 5 minutes. The options are **Enabled** and **Disabled**.

Power Button Mode

Use this option to decide whether the power button turns off the system instantly or waits 4 seconds when pressed. The options are **Instant Off** and **4 Seconds Override**.

Restore on AC Power Loss

Use this option to set the power state after a power outage. Select **Power-Off** for the system power to remain off after a power loss. Select **Power-On** for the system power to be turned on after a power loss. Select **Last State** to allow the system to resume its last state before a power loss. The options are **Power-On**, **Power-Off**, and **Last State**.

Interrupt 19 Capture

Interrupt 19 is the software interrupt that handles the boot disk function. When you set this item to **Enabled**, the host adaptors ROM BIOS “captures” interrupt 19 at boot and allows the drives attached to these host adaptors to function as bootable disks. If you set this item to **Disabled**, the host adaptors ROM BIOS does not capture interrupt 19, and the drives attached to these adaptors do not function as bootable devices. The options are **Enabled** and **Disabled**.

Processor and Clock Options



Caution Be careful when changing the advanced settings. An incorrect value, very high DRAM frequency, or incorrect DRAM timing may cause the system to become unstable. If this occurs, revert to the default setting.

CPU Ratio

Use this option to use the CPU clock multiplier to multiply CPU speed to enhance performance. Select **Manual** to set the multiplier setting manually. Select **Auto** for the BIOS to select the CPU multiplier setting for your system automatically. The options are **Default** and **Manual**.

Clock Spread Spectrum

Select **Enable** to use the clock spectrum feature, which allows the BIOS to monitor and reduce the electromagnetic interference level that the components cause. Select **Disabled** to enhance system stability. The options are **Disabled** and **Enabled**.

Hardware Prefetcher (Available Subject to CPU Support)

If set to **Enabled**, the hardware prefetcher prefetches streams of data and instructions from the main memory to the L2 cache in the forward or backward manner to improve CPU performance. The options are **Disabled** and **Enabled**.

Adjacent Cache Line Prefetch (Available Subject to CPU Support)

The CPU fetches the cache line for 64 bytes if you set this option to **Disabled**. If you set this option to **Enabled**, the CPU fetches both cache lines for 128 bytes as comprised.

MPS and ACPI MADT Ordering

Use this option to choose the ordering method for the Multiple ACPI Description Table (MADT). Select **Modern Ordering** for Windows XP or later. Select **Legacy Ordering** for Microsoft Windows 2000 or earlier. The options are **Modern Ordering** and **Legacy Ordering**.

Intel Virtualization Technology (Available Subject to CPU Support)

Select **Enabled** to use the virtualization technology feature to allow one platform to run multiple OSs and applications in independent partitions, creating multiple “virtual” systems in one physical computer. The options are **Enabled** and **Disabled**.



Note If you change to this setting, you must power off and restart the system for the change to take effect. Refer to www.intel.com/technology/virtualization for detailed information.

Execute Disable Bit Capability (Available Subject to OS and CPU Support)

Set to **Enabled** to enable the Execute Disable Bit, which allows the processor to designate areas in the system memory where application code can execute and where it cannot, thus preventing a worm or virus from flooding illegal codes to overwhelm the processor or damage the system during an attack. The default is **Enabled**. (Refer to the Intel and Microsoft Web sites for more information.)

Simultaneous Multithreading (Available Subject to CPU Support)

Set to **Enabled** to use hyperthreading technology for increased CPU performance. The options are **Disabled** and **Enabled**.

Active Processor Cores

Set to **Enabled** to use a processor’s second core and beyond. (Refer to the Intel Web site for more information.) The options are **All**, **1**, **2**, **3**, and **4**.

Intel EIST Technology

With Enhanced Intel SpeedStep Technology (EIST), the system can adjust processor voltage and core frequency automatically to reduce power consumption and heat dissipation. Refer to the Intel Web site for detailed information. The options are **Disabled** and **Enabled**.

Intel Turbo Boost Technology (Available If Intel EIST is Enabled)

With this option, processor cores can run faster than the marked frequency in specific conditions. The options are **Disabled** and **Enabled**.

C1E Support

Select **Enabled** to use the Enhanced Halt State feature. C1E significantly reduces CPU power consumption by reducing the CPU clock cycle and voltage during a Halt State. The options are **Disabled** and **Enabled**.

Intel C-State Tech

If enabled, the system automatically sets the C-state to either C2, C3, or C4 state. The options are **Default** and **Enabled**.

C-State Package Limit Setting

If set to **Auto**, the AMI BIOS automatically sets the C-state package register limit. The options are **Auto**, **C1**, **C3**, **C6**, and **C7**.

C1 Auto Demotion

When enabled, the CPU conditionally demotes C3, C6, or C7 requests to C1 based on un-core auto-demote information. The options are **Disabled** and **Enabled**.

C3 Auto Demotion

When enabled, the CPU conditionally demotes C6 or C7 requests to C3 based on un-core auto-demote information. The options are **Disabled** and **Enabled**.

Advanced Chipset Control

The **Advanced Chipset Control** submenu includes the following items.

Memory Remap Feature

Enable this option to remap overlapped PCI memory above the total physical memory. The settings are **Enabled** and **Disabled**.

Intel VT-d

Select **Enabled** to enable Intel virtualization technology support for direct I/O VT-d by reporting the I/O device assignments to VMM through the DMAR ACPI tables. This feature offers fully protected I/O resource sharing across Intel platforms for greater reliability, security, and availability in networking and data sharing. The settings are **Enabled** and **Disabled**.

Active State Power Management

Select **Enabled** to start Active State Power Management for signal transactions between L0 and L1 links on the PCI Express bus. This maximizes power saving and transaction speed. The options are **Enabled** and **Disabled**.

Route Port 80h Cycles to

Use this option to send debug information to a specific bus. The options are **Disabled**, **PCI**, and **LPC**.

USB Functions

Use this option to decide the number of onboard USB ports to enable. The options are **Disabled** and **Enabled**.

Legacy USB Support (Available if USB Functions is Enabled)

Select **Enabled** to use legacy USB devices. If you set this item to **Auto**, legacy USB support is enabled automatically if a legacy USB device is installed on the motherboard, and vice versa. The settings are **Disabled**, **Enabled**, and **Auto**.

SATA/Floppy Configuration

When you select this submenu, the AMI BIOS automatically detects IDE device presence and displays the following items.

Floppy A

Use this option to select the type of floppy drive connected to the system. The options are **Disabled**, **360 KB 5 1/4"**, **1.2 MB 5 1/4"**, **720 KB 3 1/2"**, **1.44 MB 3 1/2"**, and **2.88 MB 3 1/2"**.

SATA#1 Configuration

Selecting **Compatible** sets SATA#1 to legacy compatibility mode, while selecting **Enhanced** sets SATA#1 to native SATA mode. The options are **Disabled**, **Compatible**, and **Enhanced**.

Configure SATA as

Use this item to select the SATA#1 drive type. The options are **IDE**, **RAID**, and **AHCI**.

PCH RAID CodeBase

Select **Intel** to enable the Intel SATA HostRAID Utility. Select **Adaptec** to use the Adaptec HostRAID Utility. The options are **Intel** and **Adaptec**.

SATA#2 Configuration (Available If IDE Is Enabled Under Configure SATA#1 as)

Select **Enhanced** to set SATA#2 to native SATA mode. The options are **Disabled** and **Enhanced**.

IDE Detect Timeout (sec)

Use this option to set the timeout value for the BIOS to detect the ATA and ATAPI devices installed in the system. The options are **0** (seconds), **5**, **10**, **15**, **20**, **25**, **30**, and **35**.

SATA 0 ~ 5r

Use these settings to set the parameters of the disc storage devices attached to the SATA ports. Press <Enter> to activate the submenu screen for detailed item options. Set the correct configurations accordingly. The submenu items are listed below.

Type

Select the device type connected to the system. The options are **Not Installed**, **Auto**, **CD/DVD**, and **ARMD**.

LBA/Large Mode

Logical Block Addressing (LBA) is a method of addressing data on a disk drive. In the LBA mode, the maximum drive capacity is 137 GB. For drive capacities over 137 GB, your system must be equipped with a 48-bit LBA mode addressing. If not, install an ATA/133 IDE controller card that supports 48-bit LBA mode. The options are **Disabled** and **Auto**.

Block (Multi-Sector Transfer)

Block Mode boosts the IDE drive performance by increasing the amount of data transferred. You can transfer only 512 bytes of data per interrupt if you do not use Block Mode. Block Mode allows transfers of up to 64 KB per interrupt. If you select **Disabled**, data can transfer to and from the device one sector at a time. If you select **Auto**, data can transfer to and from the device multiple sectors at a time if the device supports this transfer method. The options are **Auto** and **Disabled**.

PIO Mode

The IDE Programmable I/O (PIO) mode programs timing cycles between the IDE drive and programmable IDE controller. As the PIO mode increases, the cycle time decreases. The options are **Auto**, **0**, **1**, **2**, **3**, and **4**.

If you select **Auto**, the AMI BIOS detects the PIO mode automatically. Use this value if you cannot determine IDE disk drive support.

If you select **0**, the AMI BIOS uses PIO mode 0. The data transfer rate is 3.3 Mbytes/s.

If you select **1**, the AMI BIOS uses PIO mode 1. The data transfer rate is 5.2 Mbytes/s.

If you select **2**, the AMI BIOS uses PIO mode 2. The data transfer rate is 8.3 Mbytes/s.

If you select **3**, the AMI BIOS uses PIO mode 3. The data transfer rate is 11.1 Mbytes/s.

If you select **4**, the AMI BIOS uses PIO mode 4. The data transfer bandwidth is 32 bits. Select **Enabled** to enable 32-bit data transfer.

DMA Mode

If you select **Auto**, the BIOS detects IDE DMA mode automatically when you cannot determine IDE disk drive support.

If you select **SWDMA0**, the BIOS uses single word DMA mode 0. The data transfer rate is 2.1 Mbytes/s.

If you select **SWDMA1**, the BIOS uses single word DMA mode 1. The data transfer rate is 4.2 Mbytes/s.

If you select **SWDMA2**, the BIOS uses single word DMA mode 2. The data transfer rate is 8.3 Mbytes/s.

If you select **MWDMA0**, the BIOS uses multiword DMA mode 0. The data transfer rate is 4.2 Mbytes/s.

If you select **MWDMA1**, the BIOS uses multiword DMA mode 1. The data transfer rate is 13.3 Mbytes/s.

If you select **MWDMA2**, the BIOS uses multiword DMA mode 2. The data transfer rate is 16.6 Mbytes/s.

If you select **UDMA0**, the BIOS uses ultra DMA mode 0. The data transfer rate is 16.6 Mbytes/s. It has the same transfer rate as PIO mode 4 and multiword DMA mode 2.

If you select **UDMA1**, the BIOS uses ultra DMA mode 1. The data transfer rate is 25 Mbytes/s.

If you select **UDMA2**, the BIOS uses ultra DMA mode 2. The data transfer rate is 33.3 Mbytes/s.

If you select **UDMA3**, the BIOS uses ultra DMA mode 3. The data transfer rate is 66.6 Mbytes/s.

If you select **UDMA4**, the BIOS uses ultra DMA mode 4. The data transfer rate is 100 Mbytes/s.

The options are **Auto**, **SWDMA n** , **MWDMA n** , and **UDMA n** .

SMART for Hard Disk Drives

Self-Monitoring Analysis and Reporting Technology (SMART) helps predict impending drive failures. If you select **Auto**, the AMI BIOS detects hard disk drive support automatically. Select **Disabled** to prevent the AMI BIOS from using the SMART. Select **Enabled** to allow the AMI BIOS to use the SMART. to support the hard drive disk. The options are **Disabled**, **Enabled**, and **Auto**.

32-Bit Data Transfer

Select **Enable** to enable the function of 32-bit IDE data transfer. The options are **Enabled** and **Disabled**.

PCI/PnP Configuration

Use this menu to set the PCI/PnP configurations for the following items.

Clear NVRAM

This option clears the NVRAM during system boot. The options are **No** and **Yes**.

Plug & Play OS

If you select **Yes**, the OS configures Plug & Play devices. (This is not required for system boot if your system has an OS that supports Plug & Play.) If you select **No**, the AMI BIOS configures all devices in the system.

PCI Latency Timer

This option sets the latency timer of each PCI device installed on a PCI bus. Select **64** to set the PCI latency to 64 PCI clock cycles. The options are **32, 64, 96, 128, 160, 192, 224, and 248**.

PCI IDE Bus Master

When enabled, the BIOS uses PCI bus mastering for reading/writing to IDE drives. The options are **Disabled** and **Default**.

PCIe I/O Performance

This feature selects the setting for the IOH PCI Express maximum payload size. The options are **128B** and **256B**.

ROM Scan Ordering

This option determines what kind of option ROM activates over another. The options are **Onboard First** and **Add-On First**.

PCI Slot 1, PCIe Slot 2 & 6 OPROM

Use this option to enable or disable PCI slot option ROMs. The options are **Disabled** and **Enabled**.

Load Onboard LAN1 Option ROM

This option enables or disables the onboard LAN option ROMs. The options are **Disabled** and **Enabled**.

Load Onboard LAN2 Option ROM

This option enables or disables the onboard LAN option ROMs. The options are **Disabled** and **Enabled**.

Boot Graphics Adapter Priority

Use this option to select the graphics controller used as the primary boot device. The options are **Other, Onboard VGA, and Slot 6**. Select **Slot 6** if a graphics controller is installed in the CPU-controlled slot 6 slot.

Super IO Device Configuration

This menu includes the following options.

Serial Port1 Address/Serial Port2 Address

This option specifies the Serial Port 1 and Serial Port 2 base I/O port address and Interrupt Request address. Select **Disabled** to prevent the serial port from accessing any system resources. When you set this option to **Disabled**, the serial port physically becomes unavailable. If you select **3F8/IRQ4**, the serial port uses 3F8 as its I/O port address and IRQ 4 for the interrupt address. The options for Serial Port1 are **Disabled**, **3F8/IRQ4**, and **2E8/IRQ3**. The options for Serial Port2 are **Disabled**, **2F8/IRQ3**, and **2E8/IRQ3**.

Onboard Floppy Controller

Select **Enabled** to enable the onboard floppy controller. The options are **Enabled** and **Disabled**.

Remote Access Configuration

This menu includes the following items.

Remote Access

Use this option to enable the Remote Access feature. The options are **Disabled** and **Enabled**.

If you set Remote Access to **Enabled**, the following items display.

Serial Port Number

Use this option to select the serial port for console redirection. The options are **COM 1**, **COM 2**, and **COM 3**.



Note Serial Over LAN (SOL) is enabled on COM 3 on the X8SIE-F and X8SI6-F.

Serial Port Mode

Use this option to set the serial port mode for Console Redirection. The options are **115200 8, n, 1**; **57600 8, n, 1**; **38400 8, n, 1**; **19200 8, n, 1**; and **9600 8, n, 1**.

Flow Control

Use this option to set the flow control for Console Redirection. The options are **None**, **Hardware**, and **Software**.

Redirection After BIOS POST

Select **Disabled** to turn off Console Redirection after Power-On Self-Test (POST). Select **Always** to keep Console Redirection active all the time after POST. (Some OSs may not support this setting.) Select **Boot Loader** to keep Console Redirection active during POST and Boot Loader. The options are **Disabled**, **Boot Loader**, and **Always**.

Terminal Type

Use this option to select the target terminal type for Console Redirection. The options are **ANSI**, **VT100**, and **VT-UTF8**.

VT-UTF8 Combo Key Support

This option is a terminal keyboard definition for sending commands from a remote console. Available options are **Enabled** and **Disabled**.

Sredir Memory Display Delay

This feature defines the length of time in seconds to display memory information. The options are **No Delay**, **Delay 1 Sec**, **Delay 2 Sec**, and **Delay 4 Sec**.

Hardware Health Configuration

Use this menu to monitor system hardware health and review the status of each item when displayed.

CPU Overheat Alarm

Use this option to select the CPU Overheat Alarm setting, which determines when the CPU overheat alarm is activated to warn of possible CPU overheat.



Caution Any temperature that exceeds the CPU threshold temperature that the CPU manufacturer predefines may result in CPU overheat or system instability. When the CPU temperature reaches this predefined threshold, the CPU and system cooling fans run at full speed.

The options are:

- **Early Alarm**—Select this setting to trigger the CPU overheat alarm (including the LED and buzzer) as soon as the CPU temperature reaches the CPU overheat threshold that the CPU manufacturer predefines.
- **Default Alarm**—Select this setting to trigger the CPU overheat alarm (including the LED and buzzer) when the CPU temperature reaches about 5 °C above the threshold temperature that the CPU manufacturer predefines, to give the CPU and system fans additional time needed for CPU and system cooling. In both the alarms above, take immediate action as described below.

System Temperature

This option displays the absolute system temperature (for example, 34 °C).

CPU Temperature

The CPU Temperature option displays the CPU temperature status as the BIOS detects it:

- **Low**—This level is considered the normal operating state. The CPU temperature is well below the CPU temperature tolerance. The motherboard fans and CPU run normally as configured in the BIOS (Fan Speed Control).

User Intervention: No action required.

- **Medium**—The processor is running warmer. This is a precautionary level and generally means there may be factors contributing to this condition, but the CPU still is within its normal operating state and below the CPU temperature tolerance. The motherboard fans

and CPU run normally as configured in the BIOS. The fans may adjust to a faster speed depending on the Fan Speed Control settings.

User Intervention: No action is required. However, consider checking the CPU fans and chassis ventilation for blockage.

- **High**—The processor is running hot. This is a caution level, because the CPU temperature tolerance has been reached (or has been exceeded) and may activate an overheat alarm:
 - **Default Alarm**—The Overheat LED and system buzzer activate if the High condition continues for some time after it is reached. The CPU fan runs at full speed to bring down the CPU temperature. If the CPU temperature still increases even with the CPU fan running at full speed, the system buzzer activates and the Overheat LED turns on.
 - **Early Alarm**—The Overheat LED and system buzzer are activated exactly when the High level is reached. The CPU fan runs at full speed to bring down the CPU temperature.



Caution In both the alarms above, take immediate action as described below.

Refer to the [CPU Overheat Alarm](#) section to modify the above alarm settings.

User Intervention: If the system buzzer and Overheat LED has activated, take action immediately by checking the system fans, chassis ventilation, and room temperature to correct any problems.



Note The system may shut down if it continues for a long period to prevent damage to the CPU.



Note In its newer processors, Intel has upgraded the CPU thermal technology that reports absolute temperatures (Celsius/Fahrenheit) to a more advanced feature. The basic concept is that each CPU has unique embedded temperature information that the motherboard can read. This temperature threshold or temperature tolerance is assigned at the factory and is the baseline by which the motherboard takes action during different CPU temperature conditions (for example, increasing CPU fan speed, triggering the overheat alarm, etc.). Because CPUs can have different temperature tolerances, the installed CPU now can send its temperature tolerance to the motherboard, resulting in better CPU thermal management.

The information provided above is for your reference only. For more information about thermal management, refer to the Intel Web site at www.intel.com.

Fan Speed Control Modes

Use this option to decide how the system controls the speeds of the onboard fans. The CPU temperature and fan speed are correlative. When the CPU on-die temperature increases, the fan speed also increases for effective system cooling.

Select **Full Speed** to allow the onboard fans to run at full speed (100 percent Pulse Width Modulation Duty Cycle) for maximum cooling. The **Full Speed** setting is recommended for special system configuration or debugging.

Select **Performance** for the onboard fans to run at 70 percent of the Initial PWM Cycle for better system cooling. The **Performance** setting is recommended for high-power-consuming and high-density systems.

Select **Balanced** for the onboard fans to run at 50 percent of the Initial PWM Cycle to balance the needs between system cooling and power saving. The **Balanced** setting is recommended for regular systems with normal hardware configurations.

Select **Energy Saving** for the onboard fans to run at 30 percent of the Initial PWM Cycle for best power efficiency and maximum quietness.

The options are **Full Speed (@100% of PWM Cycle)**, **Performance (@70% of PWM Cycle)**, **Balanced (@50% of PWM Cycle)**, and **Energy Saving (@30% of PWM Cycle)**.

Fan1 ~ Fan 6 Reading

This option displays the fan speed readings from fan interfaces Fan1 through Fan5. The options are **Vcore**, **AVCC**, **3.3Vcc**, **12V**, **V_DIMM**, **5V**, **-12V**, **3.3Vsb**, and **Vbat**.

ACPI Configuration

Use this menu to configure Advanced Configuration and Power Interface (ACPI) power management settings for your system.

High-Performance Event Timer

Select **Enabled** to activate the High-Performance Event Timer (HPET) that produces periodic interrupts at a much higher frequency than a real-time clock (RTC) does in synchronizing multimedia streams. This provides smooth playback and reduces the dependency on other timestamp calculation devices such as an x86 RDTSC Instruction embedded in the CPU. The High-Performance Event Timer replaces the 8254 Programmable Interval Timer. The options are **Enabled** and **Disabled**.

ACPI Aware O/S

This option enables ACPI support (if the OS supports it) to control ACPI through the OS. Otherwise, disable this feature. The options are **Yes** (enabled) and **No** (disabled).

ACPI APIC Support

Select **Enabled** to include the ACPI APIC Table Pointer in the Root System Description Table (RSDT) pointer list. The options are **Enabled** and **Disabled**.

APIC ACPI SCI IRQ

When you set this item to **Enabled**, the system supports APIC ACPI SCI IRQ. The options are **Enabled** and **Disabled**.

Headless Mode

Use this feature to enable the system to function without a keyboard, monitor, or mouse attached. The options are **Enabled** and **Disabled**.

ACPI Version Features

The options are **ACPI v1.0**, **ACPI v2.0**, and **ACPI v3.0**. Refer to the ACPI Web site at www.acpi.info/ for further explanation.

Event Log Configuration

This menu includes the following items.

View Event Log

Use this option to view the System Event Log.

Mark All Events as Read

This option marks all events as read. The options are **OK** and **Cancel**.

Clear Event Log

This option clears the event log memory of all messages. The options are **OK** and **Cancel**.

PCIe Error Log

Use this option to enable logging of errors encountered in the system PCI Express bus. The options are **Yes** and **No**.

Security Settings

The AMI BIOS provides a supervisor and user password. If you use both passwords, you must set the supervisor password first.

Supervisor Password

This option indicates whether you have set a supervisor password for the system. **Clear** means you have not set a supervisor password, and **Set** means you have set one.

User Password

This item indicates whether you have set a user password for the system. **Clear** means you have not set a user password, and **Set** means you have set one.

Change Supervisor Password

Select this feature and press <Enter> to access the submenu, then type in a new supervisor password.

User Access Level

This option is available when you set a supervisor password. Available options are:

- **Full Access**—You have full read and write access to the setup utility.
- **View Only**—You can access to the setup utility, but cannot change the fields.
- **Limited**—You can change only limited fields such as **Date** and **Time**.
- **No Access**—You do not have access to the setup utility.

Change User Password

Select this feature and press <Enter> to access the submenu, then type in a new user password.

Clear User Password

This option is available only if you set a user password.

Password Check

Available options are **Setup** and **Always**.

Boot Sector Virus Protection

When enabled, the AMI BOIS displays a warning when any program (or virus) issues a disk format command or attempts to write to the hard disk drive boot sector. The options are **Enabled** and **Disabled**.

Boot Settings

Use the following options in this menu to configure boot settings.

Boot Device Priority

Use this option to specify the boot device priority sequence. The settings are **1st boot device**, **2nd boot device**, **3rd boot device**, **4th boot device**, **5th boot device**, and **Disabled**.

- **1st boot device:** First floppy drive
- **2nd boot device:** [USB: XXXXXXXXXXXX]
- **3rd boot device:** [SATA: XXXXXXXXXXXX]
- **4th boot device:** [Network: XXXXXXXXXXXX]
- **5th boot device:** [Network: XXXXXXXXXXXX]

Hard Disk Drives

Use this option to specify the hard drive priority sequence.

- **1st drive:** [SATA: XXXXXXXXXXXX]
- **2nd drive:** [SATA: XXXXXXXXXXXX]

Removable Drives

Use this option to specify the removable drive boot sequence. The settings are **1st boot device**, **2nd boot device**, and **Disabled**.

- 1st drive
- **2nd drive:** [USB: XXXXXXXXXX]

Retry Boot Devices

Select this option to retry booting from the configured boot devices if the systems fail to boot initially. The options are **Disabled** and **Enabled**.

Exit Options

Select the **Exit** tab from the AMI BIOS Setup Utility screen to enter the Exit BIOS Setup screen.

Save Changes and Exit

When you have completed the system configuration changes, select this option to leave the BIOS Setup Utility and reboot the computer so the new system configuration parameters can take effect. Select **Save Changes and Exit** from the **Exit** menu and press <Enter>.

Discard Changes and Exit

Select this option to quit the BIOS Setup Utility without making any permanent changes to the system configuration and reboot the computer. Select **Discard Changes and Exit** from the **Exit** menu and press <Enter>.

Discard Changes

Select this option and press <Enter> to discard all changes and return to the AMI BIOS Setup Utility.

Load Optimal Defaults

To set this option, select **Load Optimal Defaults** from the **Exit** menu and press <Enter>. Then select **OK** to allow the AMI BIOS to load optimal defaults to the BIOS settings automatically. The optimal settings are for maximum system performance, but may not work best for all computer applications.

Load Fail-Safe Defaults

To set this option, select **Load Fail-Safe Defaults** from the **Exit** menu and press <Enter>. The fail-safe settings are for maximum system stability, but not for maximum performance.

POST Error Beep Codes

This section lists Power On Self Test (POST) error beep codes for the AMI BIOS. POST error beep codes are in two categories: recoverable and terminal. This section lists beep codes for recoverable POST errors.

Recoverable POST Error Beep Codes

When a recoverable error occurs during POST, the BIOS displays a POST code that describes the problem. The BIOS also may issue one of the following beep codes:

- **One long and eight short beeps:** Video configuration error.
- **One repetitive long beep:** No memory detected.
- **One continuous beep with the front panel Overheat LED on:** System overheat.

Rack Mounting



Note The rack mount kit provided with the NI RMC-8354 is intended to work with racks that are 26 to 33 in. deep. For information about installing the NI RMC-8354 into a rack that is less than 26 in. deep, refer to KnowledgeBase 4GCEKKMT at ni.com/support.

The rack mounting hardware includes:

- One pair of inner slides to be installed on the chassis.
- One pair of outer slides to be installed in the rack.
- Three pairs of short brackets for the outer slides.
- Bag of assorted fasteners.
- One pair of long brackets for the rear of the outer slides.



Caution When mounting the equipment in the rack, do not create a hazardous condition due to uneven mechanical loading.



Note One pair of short brackets includes screw threads, and the other two pairs have slots. If the short brackets are required for your specific rack mounting configuration, use the pair(s) that fits into your rack best.



Note Rack mounting hardware provided in the accessory kit, but not specifically described in the following instructions, is for other possible rack mounting configurations not mentioned in this manual. Consult any relevant literature provided with the intended rack for specific mounting information before attempting to install the NI RMC-8354.

Installing the Inner Slides

Follow these steps to install the inner slides to the NI RMC-8354:

1. Locate the right inner slide (the slide used on the right side of the chassis when facing the chassis front panel).
2. Align the four square holes on the right inner slide against the hooks on the right side of the chassis, as shown in Figure 2-1.
3. Securely attach the slide to the chassis with two M4 flathead screws.
4. Repeat steps 1–3 to install the left inner slide to the left side of the chassis.

Figure 2-1. Installing Inner Slides

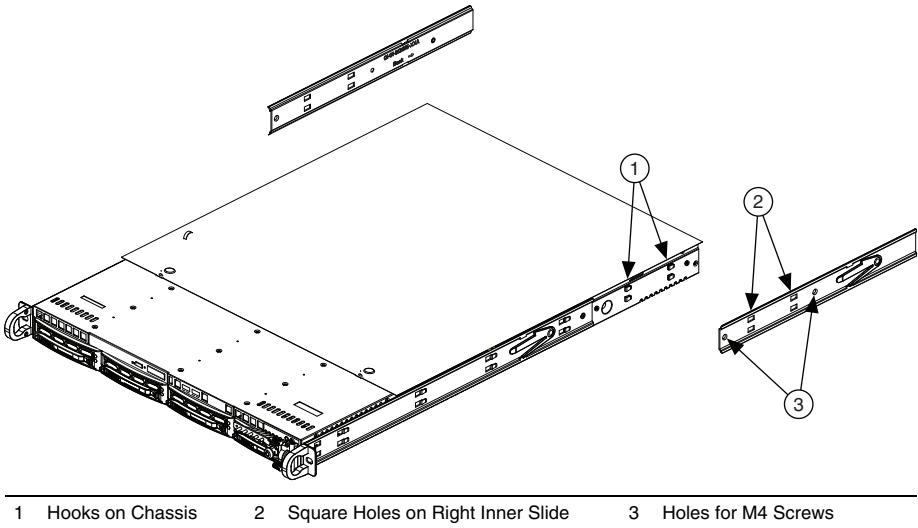

Assembling the Outer Slide Assemblies

Follow these steps to assemble the outer slide assemblies:

1. Measure the distance from the front rail of the rack to the rear rail of the rack.
2. Attach a long bracket to the rear of the right outer slide, as shown in Figure 2-2.
3. Adjust the outer slide assembly to the proper distance so that the chassis fits snugly into the rack.
4. Repeat steps 1 to 3 for the left outer slide.

Figure 2-2. Assembling Outer Slide Assemblies

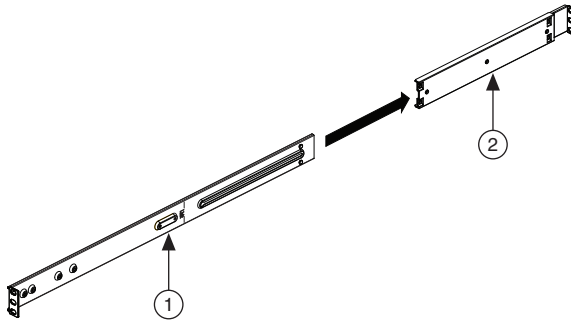

1 Outer Slide

2 Long Bracket

Installing the Outer Slide Assemblies in the Rack

Use the M5 screws and washers to secure the slide assemblies to the rack, as shown in Figure 2-3.

Figure 2-3. Installing Slide Assemblies into Rack

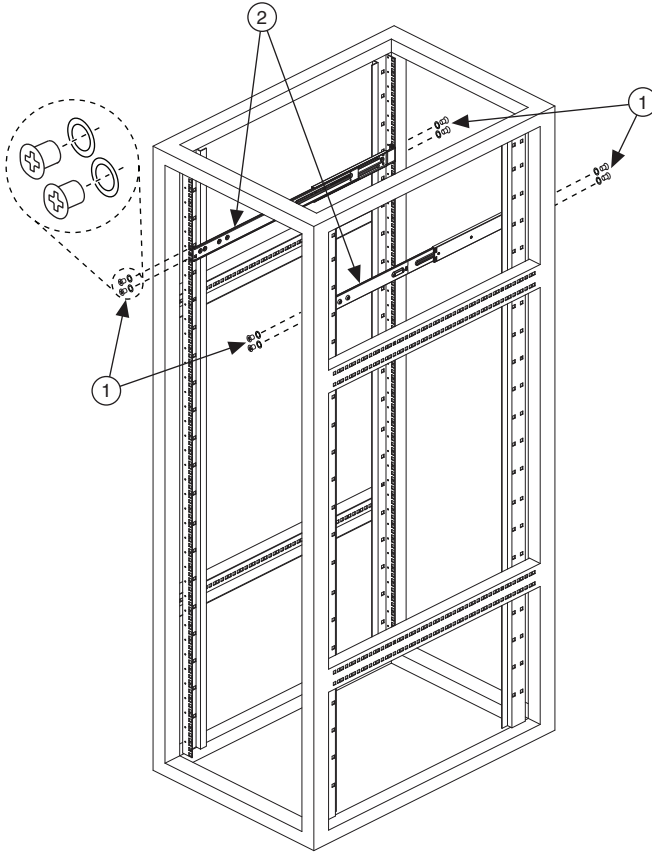

1 M5 Screws and Washers

2 Slide Assemblies

Installing the Chassis into the Rack

Follow these steps to install the chassis in the rack:

1. Push the inner slides, attached to the chassis, into the grooves of the outer slide assemblies installed in the rack, as shown in Figure 2-4.

Figure 2-4. Installing Inner Slides into Outer Slides

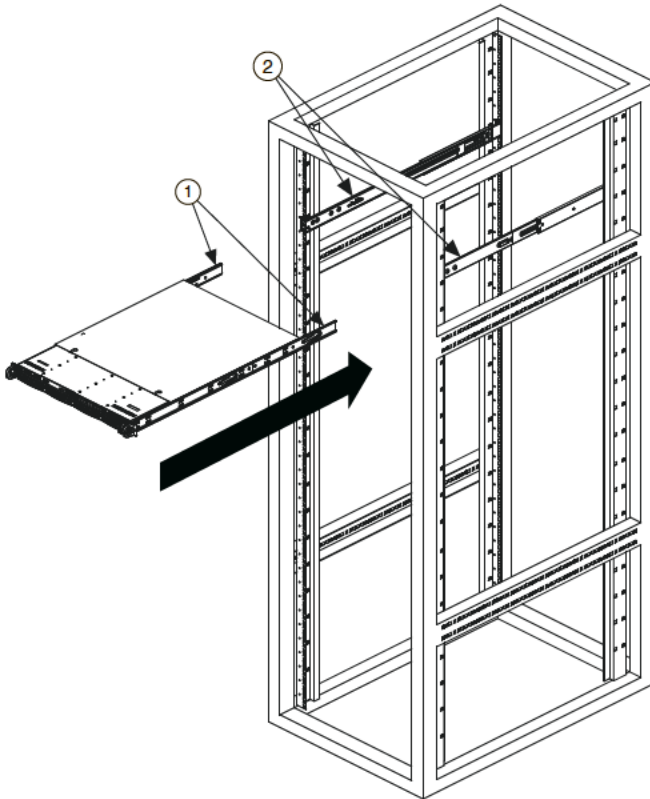

1 Inner Slides

2 Grooves of Outer Slide Assemblies

2. Push the chassis all the way to the back of the outer slide assemblies, as shown in Figure 2-5.

Figure 2-5. Installing Chassis Into Rack

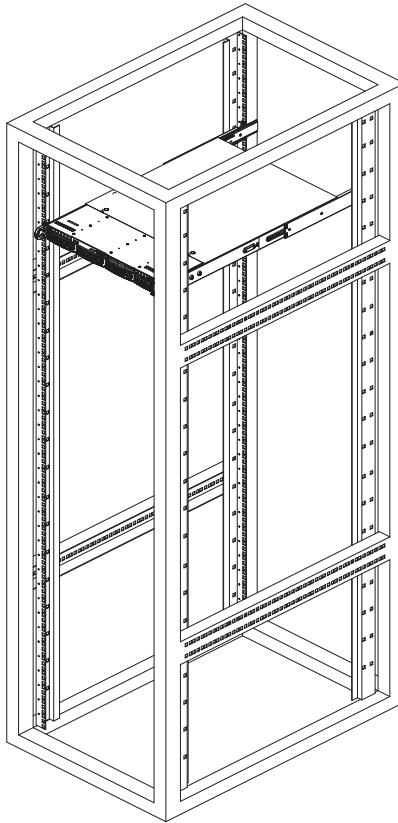

OS Reinstallation and Recovery



Caution Recovering the OS using the hard drive-based recovery or the OS recovery CD/DVD erases the contents of your hard disk. Before recovering the OS, back up any files you want to keep.

The NI RMC-8354 includes a preinstalled OS from the factory. The NI RMC-8354 also includes two methods of restoring/reinstalling the OS to your system.

- Hard drive-based recovery stores a factory backup on a separate portion of your hard drive, allowing you to restore your server without additional media.



Note The hard drive recovery hot key is <F4>. To access the hard drive-based recovery tool, press and hold <F4> when video first appears during the boot process.

- The NI RMC-8354 also ships with an OS recovery CD/DVD you can use to reinstall your operating system onto your hard drive.

If you need to reinstall your operating system, you can use the included OS recovery CD/DVD. Boot the NI RMC-8354 using the OS recovery CD/DVD to recover the OS.



Note You also may need to update or reinstall software after using the OS reinstallation CD/DVD to recover your OS. The OS reinstallation CD/DVD may contain drivers that are older or newer than the factory-installed version of the OS and may not contain the latest RAID drivers. To ensure you have the latest drivers, go to www.intel.com and install the Intel Rapid Storage Technology (Intel RST) RAID software package.



Note After you reinstall or recover your OS, you may find shortcuts on the desktop that require you to install specific drivers or software (for example, video drivers). Due to driver and software packaging, it was not possible to preinstall this software during the OS installation.

Cleaning



Caution Always disconnect the AC power cable before cleaning or servicing the chassis.

Exterior Cleaning



Caution Avoid getting moisture inside the chassis during exterior cleaning, especially through the top vents.

Do *not* wash the front- or rear-panel connectors or switches. Cover these components while cleaning the chassis.

Do *not* use harsh chemical cleaning agents; they may damage the chassis. Avoid chemicals that contain benzene, toluene, xylene, acetone, or similar solvents.

Clean the exterior surfaces of the chassis with a dry lint-free cloth or a soft-bristle brush. Do *not* use abrasive compounds on any part of the chassis.

I/O Information

This chapter describes the NI RMC-8354 I/O connectors.

Rear Panel Connectors

Table 3-1 lists various peripherals and their corresponding NI RMC-8354 external connectors, bus interfaces, and functions.

Table 3-1. NI RMC-8354 Peripherals Overview

Peripheral	External Connector	Description
Keyboard	PS/2 (5-pin Din)	PS/2-style keyboard
Mouse	PS/2 (5-pin Din)	PS/2-style mouse
USB	USB 4-pin Series A stacked receptacle	USB 2.0 capable
USB	USB 4-pin Series A stacked receptacle	USB 2.0 capable
Serial	COM1 (9-pin DSUB)	16550 RS-232 serial port
Video	VGA (15-pin DSUB)	Matrox G200eW graphics controller
Ethernet	LAN (RJ45)	10/100/1000 Ethernet connection
Ethernet	LAN (RJ45)	10/100/1000 Ethernet connection

Figure 3-1 shows the rear panel layout of the NI RMC-8354.

Figure 3-1. NI RMC-8354 Rear Panel Layout

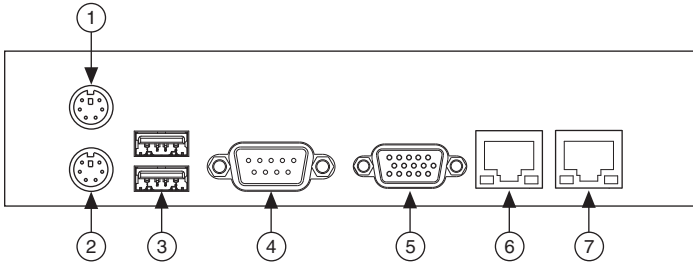

- | | | | |
|---------------------------|---------------|------------|---------|
| 1 PS/2 Mouse Connector | 3 USB Ports | 5 VGA Port | 7 LAN 2 |
| 2 PS/2 Keyboard Connector | 4 Serial Port | 6 LAN 1 | |

PS/2

Figure 3-2 shows the location and pinouts for the PS/2 keyboard and mouse connectors on the NI RMC-8354. Table 3-2 lists and describes the PS/2 connector signals.

Figure 3-2. PS/2 Connector Location and Pinout

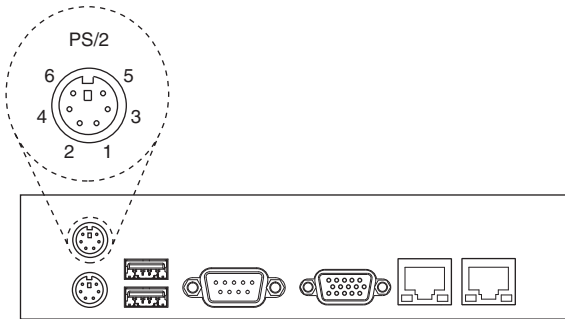

Table 3-2. PS/2 Connector Signals

Pin	Signal Name	Signal Description
1	DATA	Data Keyboard
2	NC	Data Mouse
3	GND	Ground
4	VCC	VCC
5	CLK	Clock Keyboard
6	NC	Clock Mouse

Universal Serial Bus

Figure 3-3 shows the location and pinouts for the Universal Serial Bus (USB) connectors on the NI RMC-8354. Table 3-3 lists and describes the USB connector signals.

AMP manufactures a USB mating connector, part number 787633.

Figure 3-3. USB Connector Location and Pinout

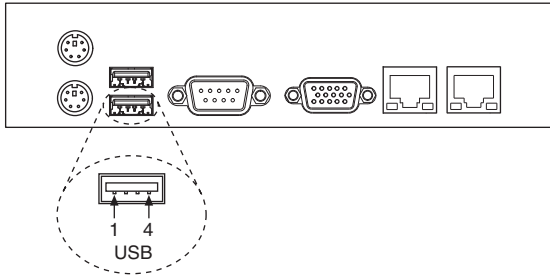

Table 3-3. USB Connector Signals

Pin	Signal Name	Signal Description
1	VCC	Cable Power (+5 V)
2	-Data	USB Data-
3	+Data	USB Data+
4	GND	Ground

Serial

Figure 3-4 shows the location and pinouts for the serial connector on the NI RMC-8354. Table 3-4 lists and describes the serial connector signal.

AMP manufactures a serial port mating connector, part number 745491-5.

Figure 3-4. Serial Connector Location and Pinout

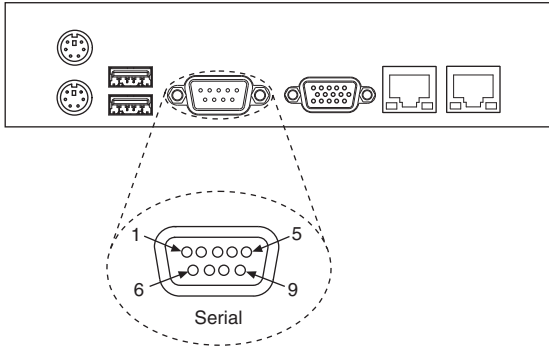

Table 3-4. Serial Connector Signals

Pin	Signal Name	Signal Description
1	DCD*	Data Carrier Detect
2	SIN*	Receive Data
3	SOUT*	Transmit Data
4	DTR*	Data Terminal Ready
5	GND	Ground
6	DSR*	Data Set Ready
7	RTS*	Ready to Send
8	CTS*	Clear to Send
9	RI*	Ring Indicator

VGA

Figure 3-5 shows the location and pinouts for the VGA connector on the NI RMC-8354. Table 3-5 lists and describes the VGA connector signals.

AMP manufactures a mating connector with part numbers 748364-1 (housing) and 748333-2 (pin contact).

Figure 3-5. VGA Connector Location and Pinout

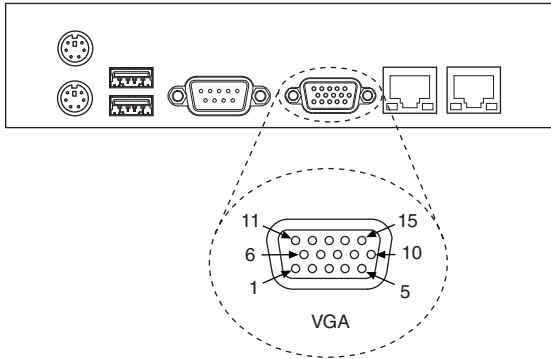

Table 3-5. VGA Connector Signals

Pin	Signal Name	Signal Description
1	R	Red
2	G	Green
3	B	Blue
4	NC	Not Connected
5	GND	Ground
6	GND	Ground
7	GND	Ground
8	GND	Ground
9	+5V	5 V
10	GND	Ground
11	NC	Not Connected
12	SD	Serial Data
13	HSync	Horizontal Sync
14	VSynC	Vertical Sync
15	SC	Serial Clock

Ethernet

Figure 3-6 shows the location and pinouts for the Ethernet connectors on the NI RMC-8354. Table 3-6 lists and describes the Ethernet connector signals.

AMP manufactures a mating connector, part number 554739-1.

Figure 3-6. Ethernet Connector Location and Pinout

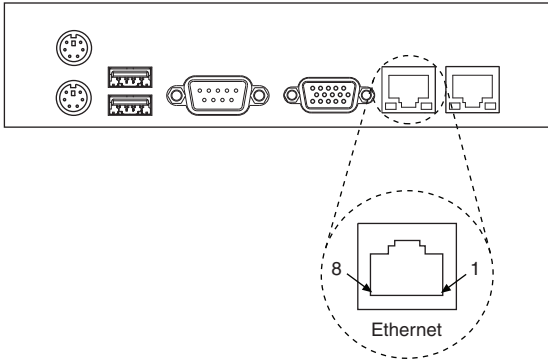

Table 3-6. Ethernet Connector Signals

Pin	Signal Name	Signal Description
1	D0P	Differential Pair 0+
2	D0N	Differential Pair 0-
3	D1P	Differential Pair 1+
4	D2P	Differential Pair 2+
5	D2N	Differential Pair 2-
6	D1N	Differential Pair 1-
7	D3P	Differential Pair 3+
8	D3N	Differential Pair 3-

MXI-Express Connectors

Refer to your MXI-Express hardware user manual for connector information.



Note The NI RMC-8354 BIOS supports only 188 PCI buses by default. For large multichassis systems requiring more than 188 PCI buses, use the NI MXI-Express BIOS compatibility software to work around this limitation on Windows. At this time, there is no workaround available for systems running LabVIEW RT. To access NI MXI-Express BIOS Compatibility Software, search for *MXI-Express BIOS Compatibility Software* at ni.com/drivers.

Common Configuration Questions

This chapter answers common configuration questions you may have when using the NI RMC-8354.

General Questions

What do the LEDs on the NI RMC-8354 front panel mean?

The power indicator lights when the main power is turned on. The LAN status LEDs flash to when there is activity on LAN1 and LAN2. The hard drive LED lights when there is hard drive activity on the NI RMC-8354. For more information, refer to Figure 1-1, *Front View of the NI RMC-8354*.

How do I check the configuration of the memory, hard drive, time/date, and so on?

You can view these parameters in the BIOS setup. To enter the BIOS setup, reboot the NI RMC-8354 and press <Delete> during the memory tests. Refer to the *BIOS Setup* section of Chapter 2, *Installation and BIOS Setup*, for more information.

Can I use the internal SATA drive and an external hard drive at the same time?

Yes.

How much noise do the fans generate?

The fans have the following noise specifications:

Sound pressure level (at operator position)

Minimum 53.9 dBA

Maximum..... 64.9 dBA

Sound power

Minimum 61.6 dBA

Maximum..... 72.0 dBA

What RAID modes are supported?

The NI RMC-8354 officially supports only RAID 5. Other RAID configurations such as RAID-0 and RAID-1 are known to function, but are not fully validated.

Does the NI RMC-8354 support a PCI card?

No, the NI RMC-8354 can support only PCI Express cards while using a riser card (provided).

What is the shortcut key to get to the boot menu while the BIOS is going through POST?

The shortcut key is <F11>.

Boot Options

What devices can I boot from?

The NI RMC-8354 can boot from the following devices:

- The internal SATA hard drive
- The internal CD-ROM drive
- A network PXE server on the same subnet
- An external USB mass storage device such as a USB hard drive or CD-ROM



Note You should enable Legacy USB support to boot from USB devices. Refer to the *BIOS Setup* section of Chapter 2, *Installation and BIOS Setup*, for more information.

- An external USB floppy drive



Note There are some limitations when booting from a USB device. Windows XP can be installed from a USB CD-ROM, but earlier versions of Windows cannot. The NI RMC-8354 BIOS configures the USB devices so that they will work in a DOS environment.

How do I configure the controller to boot from these devices?

Press <Delete>, enter the BIOS, and select **Boot**. Set the order by device type and set the order for the devices listed within the device type. Refer to *BIOS Setup* in Chapter 2, *Installation and BIOS Setup*, for more information.

Chassis Configuration

How do I set up the NI RMC-8354 to work with my PXI chassis?

Configuration of the PXI system is handled through Measurement & Automation Explorer (MAX), included with the software pre-installed on your NI RMC-8354. MAX creates the `pxi.sys.ini` file, which defines the layout and parameters of your PXI system.

The configuration steps for single or multiple-chassis systems are the same. In MAX, select **Help»Help Topics»PXI** to configure your chassis.

The PXI specification allows many combinations of PXI chassis and system modules. To assist system integrators, the manufacturers of PXI chassis and system modules must document the capabilities of their products. The minimum documentation requirements are contained in `.ini` files, which consist of ASCII text. System integrators, configuration utilities, and device drivers can use these `.ini` files.

The capability documentation for the chassis is contained in a `chassis.ini` file provided by the chassis manufacturer. The information in this file is combined with information about the system controller to create a single system initialization file called `pxisys.ini` (PXI System Initialization). The NI RMC-8354 uses MAX to generate the `pxisys.ini` file from the `chassis.ini` file.

Device drivers and other utility software read the `pxisys.ini` file to obtain system information. For detailed information about initialization files, refer to the PXI specification at www.pxisa.org.

Upgrade Information

How do I upgrade system memory?

Refer to the *Upgrading Memory* section in Appendix B, *Hardware Configuration*.

How do I flash a new BIOS?

To see if the latest BIOS is available, go to ni.com/downloads/.

Where do I get the latest software drivers?

The latest National Instruments software is available from ni.com/downloads/.

My NI RMC-8354 does not have an internal floppy drive. Is there a way to use an external drive?

Yes. The NI RMC-8354 controller supports and can boot from USB floppy drives. A USB floppy drive will not work with Windows NT4, but will work with Windows 2000 or Windows XP. Refer to the *Boot Options* section for more information.

A USB floppy drive is available from National Instruments, part number 778492-02.

Troubleshooting

This chapter answers common troubleshooting questions you may have when using the NI RMC-8354.

What if the NI RMC-8354 does not boot?

Several problems can cause a controller not to boot. Here are some things to look for and possible solutions.

Things to Notice:

- Which LEDs come on? The power indicator LED should stay lit. The hard disk drive LEDs should blink during boot as the disk is accessed.
- What appears on the display? Does it hang at some particular point (BIOS, Operating System, and so on)? If nothing appears on the screen, try a different monitor. Does your monitor work with a different PC? If it hangs, note the last screen output that you saw for reference when consulting National Instruments technical support.
- What has changed about the system? Did you recently move the system? Was there electrical storm activity? Did you recently add a new module, memory chip, or piece of software?
- Has the system overheated? If the Overheat/FanFail LED is lit, this indicates overheating. Unplug the AC power cord from the server and allow it to cool down before powering it on again.
- Has any memory been installed in the unsupported slots? (Refer to the [Memory Upgrades](#) section in Chapter 1, [Getting Started](#), for more information.)

Things to Try:

- Make sure the NI RMC-8354 is plugged in to a working power source.
- Remove any nonessential cables or devices.
- Make sure the CPU and memory modules are properly seated in their slots.
- Clear the CMOS. (Refer to the [Clear CMOS Jumper: JBT1](#) section of Appendix B, [Hardware Configuration](#).)
- Recover the hard drive on the NI RMC-8354. (Refer to the [OS Reinstallation and Recovery](#) section of Chapter 2, [Installation and BIOS Setup](#).)
- Remove memory from unsupported slots.

My NI RMC-8354 boots fine until I get to Windows, at which point I cannot read the screen. This may include garbled output, white screen, black screen, or an out of synch message from the monitor.

This problem usually results from having the video card output set past the limits of the monitor. You will need to boot Windows in Safe Mode. To do this, reboot the NI RMC-8354. As Windows begins to boot, hold down <F8>. You should now be able to reset the video driver to lower settings. Try setting the resolution to 640 × 480 and the refresh rate to 60 Hz. Once you reboot, you can raise these values again, using the test option in Windows. These settings are accessible through the **Advanced** tab of the **Display** item in the **Control Panel**. Alternately, you can try a different monitor, preferably a newer and larger one.

My system boots fine as long as a particular module is not in my chassis.

The most common cause of this is a damaged module. Try the module in a different chassis or with a different controller. Also, remove any external cables or terminal blocks connected to the system. If the module does not work in these cases, it is likely damaged. Contact the module manufacturer for further troubleshooting.

Refer to the KnowledgeBase or product manuals section at ni.com for more information specific to the chassis and module with which you are having difficulties.

How do I set Windows to prompt me before shutting down when I press the power button?

Select **Start»Control Panel»Power Options** to open the **Power Options Properties** window. Select the **Advanced** tab. In the **Power buttons** section, select **Ask me what to do** from the pull-down menu. When this is selected, Windows prompts you to cancel, shut down, or restart when you press the power button.

Specifications

This appendix lists the NI RMC-8354 electrical, mechanical, and environmental specifications.

Electrical

AC Input

Input voltage range	100 to 240 VAC
Operating voltage range ¹	90 to 264 VAC
Input frequency	50/60 Hz
Operating frequency range ¹	47 to 63 Hz
Input current rating	5 A max
Power disconnect	The AC power cable provides main power disconnect. Depressing the front panel power switch enables or inhibits the internal power supply.

Power Requirements

Measured, peak inrush (power ON)	197 W
Measured, idle	92 W
Measured, active (100% CPU)	203 W

Mainboard

Socket	LGA 1156
Chipset	Intel 3420 chipset
Memory Slots	Four 240-pin DIMM slots, three per channel, 1066/1333 16 GB max memory
PCI Express	One PCI Express 2.0 x16 slot
SATA	Six SATA ports compliant with the Serial-ATA 2.0 specification.
USB ports	Four USB 2.0 ports
Keyboard	PS/2 keyboard port
Mouse	PS/2 mouse port

¹ Operating range is guaranteed by design.

Video	VGA port, onboard Matrox G200eW 16 MB DDR2 (max resolution 1280 × 1024)
Serial	One RS-232 serial port
LAN	Two RJ45 LAN jacks
Onboard LAN controller.....	Intel 82574L Gigabit Ethernet controller

CPU

CPU.....	Intel i7 860 Quad Core
Clock speed.....	2.86 GHz
Max turbo frequency (single core).....	3.46 GHz
Intel Smart Cache.....	8 MB
Package	LGA 1156

Hard Disk Drive

Capacity	500 GB in one, two, or four-drive configurations for maximum capacity of 2 TB (maximum usable capacity shown by Windows in RAID 5 is 1.36 TB)
Interface	Serial-ATA

Memory

Standard memory	1/2 × 1 GB (128 M × 72 bit), DDR-III SDRAM, ECC 1333 MHz
4 GB memory upgrade.....	2 × 2 GB (128 M × 72 bit), DDR-III SDRAM, ECC 1333 MHz
8 GB memory upgrade (64-bit OS)	4 × 2 GB (128 M × 72 bit), DDR-III SDRAM, ECC 1333 MHz
16 GB memory upgrade (64-bit OS)	4 × 4 GB (512 M × 72 bit), DDR-III SDRAM, ECC 1333 MHz

Mechanical

Overall dimensions (standard chassis)	
Height.....	1U
Width.....	437 mm (17.2 in.)
Depth.....	503 mm (19.8 in.)
Weight (with four 500 GB drives)	10.75 kg (23.7 lbs)

Environmental



Caution If installed in a closed or multiunit rack assembly, the rack environment operating ambient temperature may be greater than room ambient temperature. Therefore, install the equipment in an environment compatible with the maximum ambient temperature (T_{ma}) the manufacturer specifies.

Operating temperature	5 to 35 °C (Tested in accordance with IEC 60068-2-1.)
Storage temperature	-40 to 70 °C (Tested in accordance with IEC 60068-2-1 and IEC 60068-2-2.)
Relative humidity (tested in accordance with IEC 60068-2-56)	
Operating	10 to 90% noncondensing
Nonoperational (storage)	5 to 95% noncondensing
Operating location	Indoor use
Altitude	2,000 m
Installation Category	II
Pollution Degree	2

Acoustic Emissions¹

Sound pressure level (at operator position)	
Minimum	53.9 dBA
Maximum	64.9 dBA
Sound power	
Minimum	61.6 dBA
Maximum	72.0 dBA

Safety

This product is designed to meet the requirements of the following standards of safety for information technology equipment:

- IEC 60950-1, EN 60950-1
- UL 60950-1, CSA 60950-1



Caution Overloading the circuits may damage supply wiring. Do not exceed the ratings on the equipment nameplate when connecting equipment to the supply circuit.



Note For UL and other safety certifications, refer to the product label or the [Online Product Certification](#) section.

¹ Typical data. Tested in accordance with ISO 7779; meets MIL-PRF-28800F requirements.

Electromagnetic Compatibility

This product meets the requirements of the following EMC standards for electrical equipment for measurement, control, and laboratory use:

- EN 61326 (IEC 61326): Class A emissions; Basic immunity
- EN 55011 (CISPR 11): Group 1, Class A emissions
- AS/NZS CISPR 11: Group 1, Class A emissions
- FCC 47 CFR Part 15B: Class A emissions
- ICES-001: Class A emissions



Note For the standards applied to assess the EMC of this product, refer to the *Online Product Certification* section.



Note For EMC compliance, operate this device with shielded cabling.

CE Compliance

This product meets the essential requirements of applicable European Directives as follows:

- 2006/95/EC; Low-Voltage Directive (safety)
- 2004/108/EC; Electromagnetic Compatibility Directive (EMC)

Online Product Certification

Refer to the product Declaration of Conformity (DoC) for additional regulatory compliance information. To obtain product certifications and the DoC for this product, visit ni.com/certification, search by model number or product line, and click the appropriate link in the Certification column.

Environmental Management

NI is committed to designing and manufacturing products in an environmentally responsible manner. NI recognizes that eliminating certain hazardous substances from our products is beneficial to the environment and to NI customers.

For additional environmental information, refer to the *Minimize Our Environmental Impact* web page at ni.com/environment. This page contains the environmental regulations and directives with which NI complies, as well as other environmental information not included in this document.

Waste Electrical and Electronic Equipment (WEEE)



EU Customers At the end of the product life cycle, all products *must* be sent to a WEEE recycling center. For more information about WEEE recycling centers, National Instruments WEEE initiatives, and compliance with WEEE Directive 2002/96/EC on Waste and Electronic Equipment, visit ni.com/environment/weee.

Battery Replacement and Disposal



Caution Risk of explosion if battery is replaced by an incorrect type. Dispose of used batteries according to instructions.



Battery Directive This device contains a long-life coin cell battery. If you need to replace it, use the Return Material Authorization (RMA) process or contact an authorized National Instruments service representative. For more information about compliance with the EU Battery Directive 2006/66/EC about Batteries and Accumulators and Waste Batteries and Accumulators, visit ni.com/environment/batterydirective.

电子信息产品污染控制管理办法（中国 RoHS）



中国客户 National Instruments 符合中国电子信息产品中限制使用某些有害物质指令 (RoHS)。关于 National Instruments 中国 RoHS 合规性信息，请登录 ni.com/environment/rohs_china。(For information about China RoHS compliance, go to ni.com/environment/rohs_china.)

Hardware Configuration

This appendix describes how to configure and upgrade the NI RMC-8354 hardware.



Caution Hazardous Voltage Area

No user (operator) serviceable parts are inside the NI RMC-8354.

The hardware configuration and upgrade procedures described in this appendix *must* be performed only by a qualified service technician.

Disconnect the power cord before servicing.

Figure B-1 shows the key features of the NI RMC-8354 mainboard.

Figure B-1. NI RMC-8354 Mainboard Layout

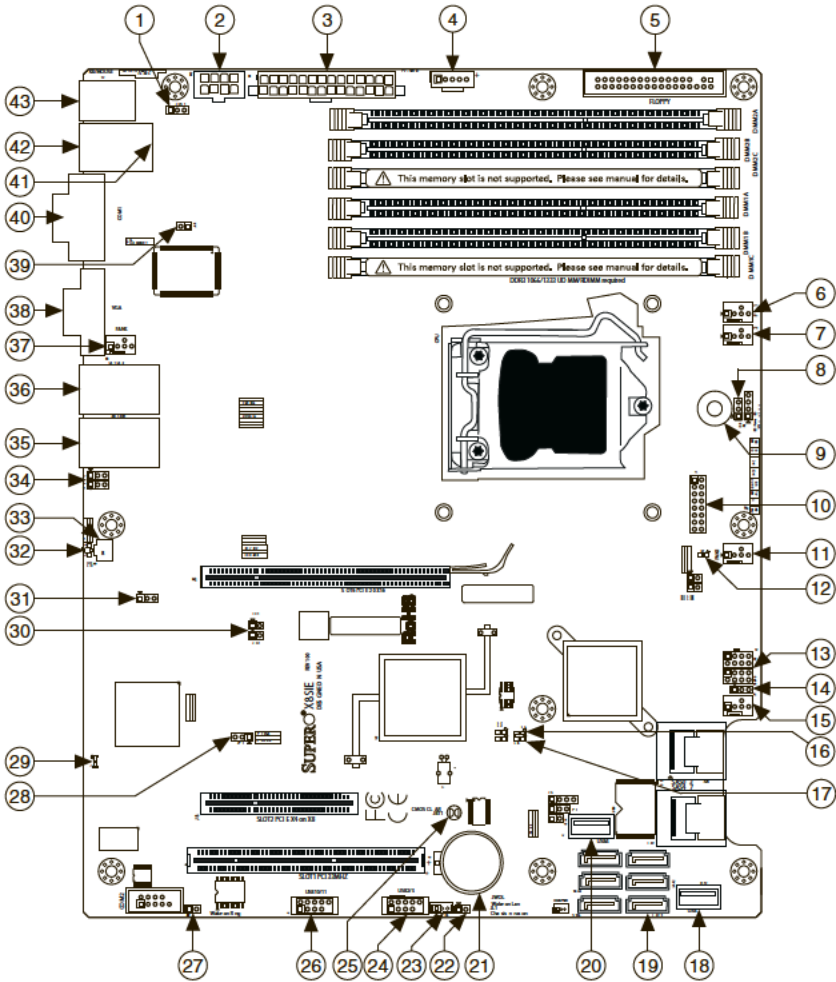

1	JUSB1	12	LE4	23	JWOL	34	JPL1/2
2	JPW2	13	T-SGPIO0/1	24	USB2/3	35	LAN2
3	JPW1	14	JPT1	25	JBT1	36	LAN1
4	JPI2C	15	Fan4	26	USB10/11	37	Fan5
5	Floppy	16	LE6	27	JWOR	38	VGA
6	Fan1	17	LE8	28	JPG1	39	JAR
7	Fan2	18	USB5	29	LE7	40	COM1
8	JLED	19	I-SATA0-5	30	JPC1/JI2C2	41	IPMI
9	SPKR1	20	USB4	31	JPB	42	USB0/1
10	JF1	21	B1	32	UID LED	43	KB/Mouse
11	Fan3	22	JL1	33	SW1		

Jumper Settings

Figure B-2 shows the jumper locations on the NI RMC-8354.

Figure B-2. NI RMC-8354 Jumper Locations

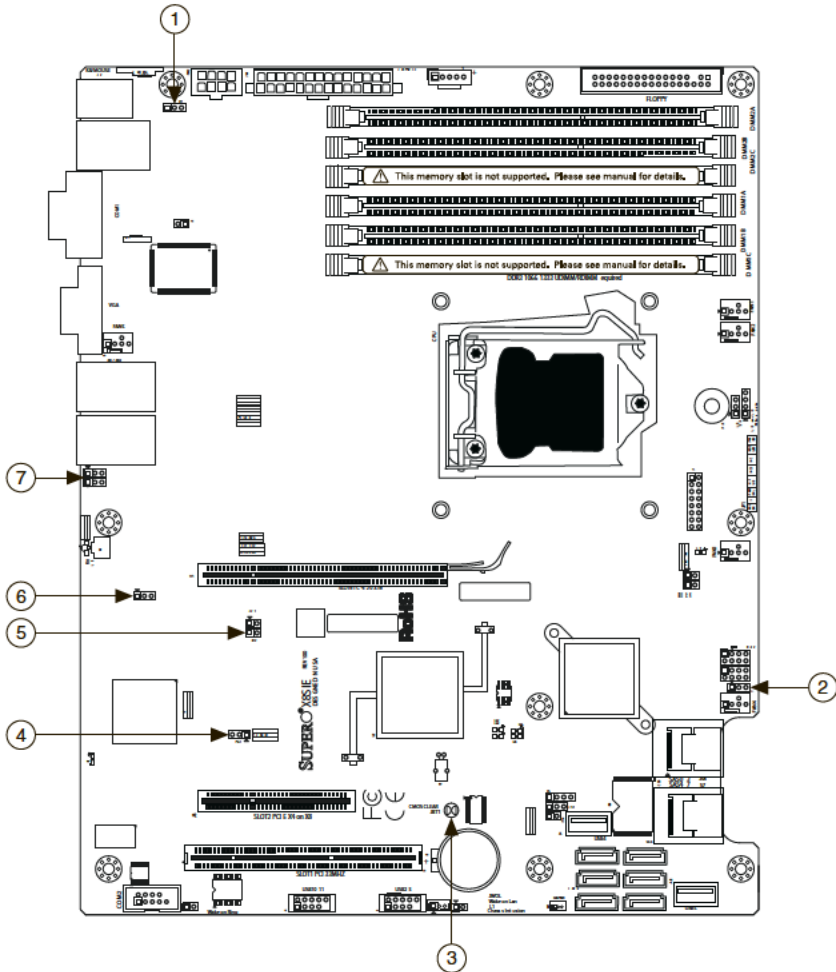

1	JUSB1	3	JBT1	5	JPC1/JPC2	7	JPL1/2
2	JPT1	4	JPG1	6	JPB		

Enable/Disable USB Wakeup Jumper: JPUSB1

Use the JPUSB1 jumper to wake up your system by pressing a key on a USB keyboard or clicking the USB mouse. Use the JPUSB1 jumper together with the USB wakeup feature in the BIOS. Enable this jumper and the USB feature in the BIOS to wake up your system via USB devices.



Note When the USB function is enabled in the BIOS, and the USB wakeup jumper is disabled, remove the USB devices from the USB ports whose USB jumper is disabled before the system goes into the standby mode.

Figure B-3. Enable/Disable USB Wakeup Jumper: JPUSB1

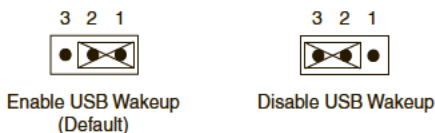

Enable/Disable Factory Test Jumper: JPT1

Use the JPT1 jumper to enable or disable the factory test. The default setting is enabled.

Figure B-4. Enable/Disable Factory Test Jumper: JPT1

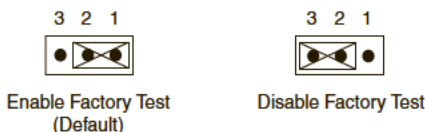

Clear CMOS Jumper: JBT1



Caution Always remove the AC power cord from the system before clearing CMOS.



Caution For an ATX power supply, you must completely shut down the system, remove the AC power cord, and then short JBT1 to clear CMOS. Do not use the PW_ON connector to clear CMOS.

Use JBT1 to clear CMOS. Instead of pins, this “jumper” consists of contact pads to prevent accidental CMOS clearing. To clear CMOS, use a metal object such as a small screwdriver to touch both pads at the same time to short the connection.

Figure B-5. Clear CMOS Jumper: JBT1



Enable/Disable VGA Connector Jumper: JPG1

Use JPG1 to enable or disable the VGA connector on the motherboard. The default setting is enabled.

Figure B-6. Enable/Disable VGA Connector Jumper: JPG1

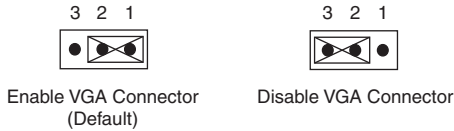

Enable/Disable SMBus to PCI/PCI Express Slots Jumper: JI²C1/JI²C2

Use jumpers JI²C1/JI²C2 to connect PCI/PCI Express slots to the system management bus. The default setting is open to disable the connection.

Figure B-7. Enable/Disable SMBus to PCI/PCI Express Slots Jumper: JI²C1/JI²C2

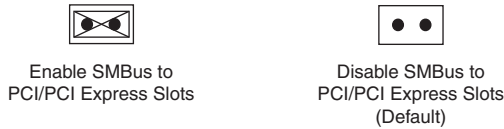

Enable/Disable BMC Jumper: JPB

Use the JPB jumper to enable or disable the Baseboard Management Control (BMC) chip and onboard IPMI connection. Use this jumper together with the IPMI settings in the BIOS. The default setting is enabled.

Figure B-8. Enable/Disable BMC Jumper: JPB

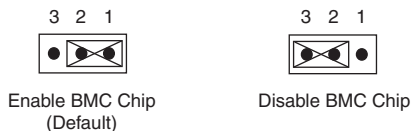

Enable/Disable GLAN1/GLAN2 Jumper: JPL1/JPL2

Use JPL1 to enable or disable the GLAN1 port and JPL2 to enable or disable the GLAN2 port on the motherboard. The default setting is enabled.

Figure B-9. Enable/Disable GLAN1/GLAN2 Jumper: JPL1/JPL2

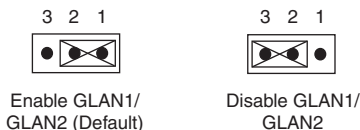

Other Connectors

Figure B-10 shows the locations of other connectors on the NI RMC-8354.

Figure B-10. NI RMC-8354 Other Connector Locations

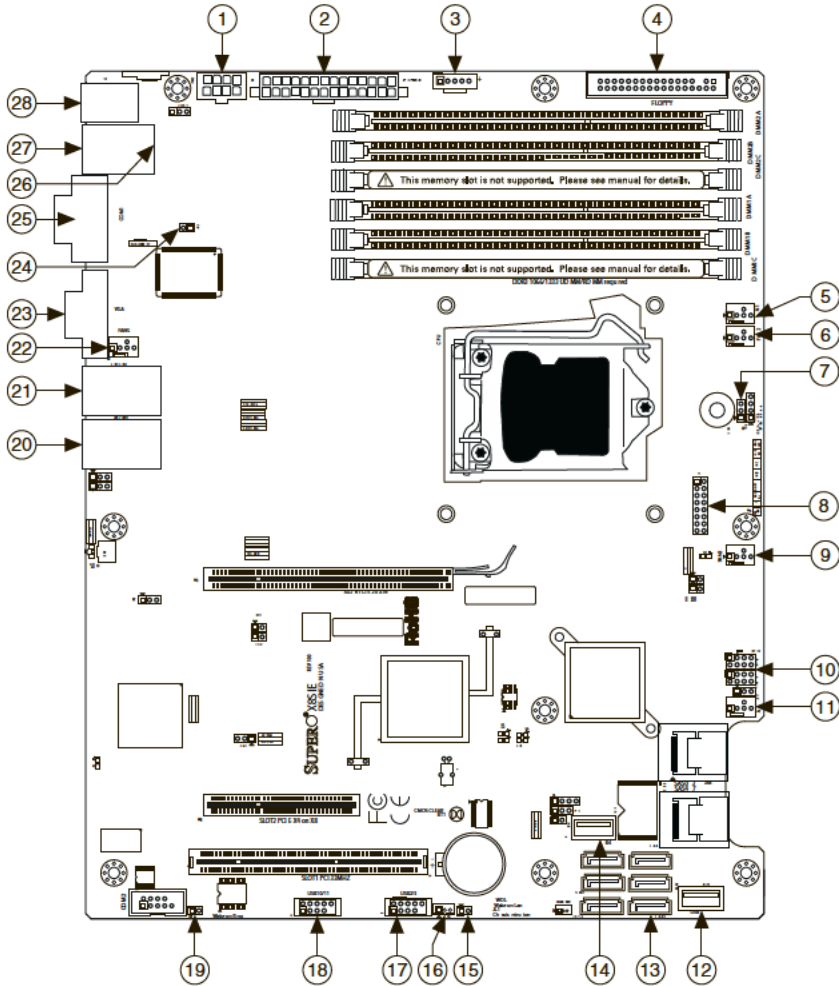

1 JPW2	8 JF1	15 JL1	22 Fan5
2 JPW1	9 Fan3	16 JWOL	23 VGA
3 JPI2C	10 T-SGPIO0/1	17 USB2/3	24 JAR
4 Floppy	11 Fan4	18 USB10/11	25 COM1
5 Fan1	12 USB5	19 JWOR	26 IPMI
6 Fan2	13 I-SATA0-5	20 LAN2	27 USB0/1
7 JLED	14 USB4	21 LAN1	28 KB/Mouse

Power Supply I²C Connector: JPI²C

JPI²C is the power supply I²C connector. This connector monitors the power supply, fan, and system temperature statuses.

Figure B-11. Power Supply I²C Connector (JPI²C)

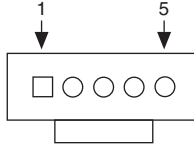

Table B-1. Power Supply I²C Connector Signal Descriptions

Pin	Signal Description
1	Clock
2	Data
3	PWR Fail
4	GND
5	3.3 V

Floppy Connector

The floppy connector is next to the DIMM memory banks on the motherboard.

Notice the following when connecting the floppy cable:

- The floppy cable has seven twisted wires.
- A red mark on a wire typically designates the pin 1 location.
- A single floppy ribbon cable has 34 wires and two connectors for two floppy drives. The connector with twisted wires always connects to drive A, and the connector without twisted wires always connects to drive B.

Figure B-12. Floppy Connector

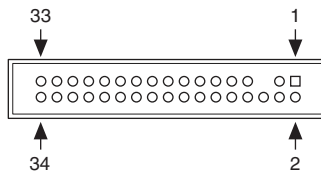

Table B-2. Floppy Connector Signal Descriptions

Pin	Signal Description	Pin	Signal Description
1	GND	2	FDHDIN
3	GND	4	Reserved
5	Key	6	FDEDIN
7	GND	8	Index
9	GND	10	Motor enable
11	GND	12	Drive select B
13	GND	14	Drive select B
15	GND	16	Motor enable
17	GND	18	DIR
19	GND	20	STEP
21	GND	22	Write data
23	GND	24	Write gate
25	GND	26	Track 00
27	GND	28	Write protect
29	GND	30	Read data
31	GND	32	Side 1 select
33	GND	34	Diskette

Fan Power Connectors: Fan1 to Fan5

The NI RMC-8354 has five fan headers (Fan1 to Fan5). These fans are 4-pin fan headers. However, pins 1 to 3 of the fan headers are backward compatible with the traditional 3-pin fans. A fan speed control setting in the BIOS allows the BIOS to set fan speeds automatically based on the system temperature. The default setting is disabled, which allows the onboard fans to run at full speed.



Note Use all 3-pin fans or all 4-pin fans on a motherboard. Do not use 3-pin fans and 4-pin fans on the same board.

Figure B-13. Fan Power Connectors (Fan1 to Fan6)

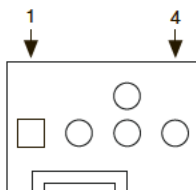

Table B-3. Fan Power Connector Signals

Pin	Signal Description
1	GND
2	2.5 A/+16 V (red)
3	Tachometer
4	PWM_Control

Onboard Power LED Header: JLED

JLED is the onboard power LED header. The power LED header is connected to front control panel at JF1 to indicate the system power status.

Figure B-14. Onboard Power LED Header (JLED)

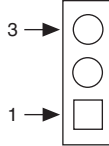

Table B-4. Onboard Power LED Header Signal Descriptions

Pin	Signal Description
1	VCC
2	No Connection
3	Connection to PWR LED on JF1

Front Panel Connector: JF1

JF1 contains header pins for various buttons and indicators on the control panel at the front of the chassis. These connectors are designed specifically for use with this chassis.

Figure B-15. Front Panel Connector (JF1)

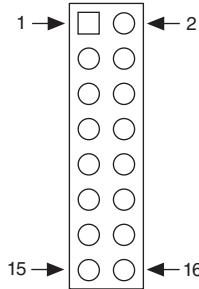

Table B-5. Front Panel Connector Signals

Pin	Signal Name	Signal Description
1	PWR	Power button signal
2	GND	Power button +3 V standby
3	Reset	Reset button reset

Table B-5. Front Panel Connector Signals (Continued)

Pin	Signal Name	Signal Description
4	GND	Reset button ground
5	LED_Anode+	Power fail LED Vcc
6	Power Fail LED	Power fail LED ground
7	UID LED	Vcc/blue UID LED
8	OH/Fan Fail LED	OH/fan fail LED
9	LED_Anode+	NIC2 LED Vcc
10	NIC2 LED	NIC2 LED ground
11	LED_Anode+	NIC1 LED Vcc
12	NIC1 LED	NIC1 LED ground
13	LED_Anode+	HDD LED +5 V
14	HDD LED	HD active
15	LED_Anode+	Power LED +5 V
16	Power LED	Power LED ground

T-SGPIO0/1 Headers

Use the two Serial-Link General Purpose Input/Output (T-SGPIO) headers to communicate with the enclosure management chip in the system.

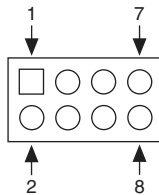
Figure B-16. T-SGPIO0/1 Header**Table B-6.** T-SGPIO0/1 Header Signal Descriptions

Pin	Signal Description	Pin	Signal Description
1	NC	2	NC
3	GND	4	DATA Out

Table B-6. T-SGPIO0/1 Header Signal Descriptions (Continued)

Pin	Signal Description	Pin	Signal Description
5	Load	6	GND
7	Clock	8	NC

Chassis Intrusion Switch Connector: JL1

JL1 is the chassis intrusion header. Attach the appropriate cable to be informed of a chassis intrusion.

Figure B-17. Chassis Intrusion Switch Connector (JL1)



Table B-7. Chassis Intrusion Switch Connector Signals

Pin	Signal Name
1	CINTRU
2	GND

Wake-On-LAN Header: JWOL

JWOL is the Wake-On-LAN header on the motherboard. You must also have a LAN card with a Wake-On-LAN connector and cable to use this feature.

Figure B-18. Wake-On-LAN Header (JWOL)

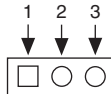

Table B-8. Wake-On-LAN Signals

Pin	Signal Description
1	+5 V Standby
2	Ground
3	Wakeup

Front USB Connectors: USB2/3 and USB10/11

Two Universal Serial Bus ports (USB0/1) are on the I/O back panel. In addition, four USB ports (USB2/3 and USB10/11) are at J13 and J14 on the motherboard. You can use these ports to provide front chassis USB access (cables not included).

Figure B-19. Front USB Connectors (USB 2/3 and USB 10/11)

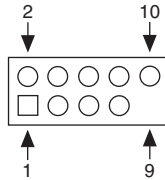

Table B-9. Front USB Connector Signals

Pin	Signal Name	Pin	Signal Name
1	VCC	6	USB1+
2	VCC	7	GND
3	USB0-	8	GND
4	USB1-	9	Key
5	USB0+	10	NC

Wake-On-Ring Header: JWOR

JWOR is the Wake-On-Ring header. Wake-On-Ring allows your computer to wake up when receiving an incoming call to the modem when in the suspend state. You must have a Wake-On-Ring card and cable to use this feature.

Figure B-20. Wake-On-Ring Header (JWOR)



Table B-10. Wake-On-Ring Header Signals

Pin	Signal Description
1	GND
2	Wakeup

Alarm Reset Header: JAR

If three power supplies are installed and Alarm Reset (JAR) is connected, the system notifies you when any of the three power modules fail. Connect JAR to a microswitch to turn off the alarm that is activated when a power module fails.

Figure B-21. Alarm Reset (JAR)



Table B-11. Alarm Reset Signals

Pin	Signal Description
1	Ground
2	+5V

PCI Express Slot

This slot is PCI Express Specification v2.0 compliant.

Figure B-22. PCI Express Slot



Upgrading Memory

The mainboard includes six 240-pin ECC DDR-III SDRAM slots with maximum memory size of 16 GB.

Figure B-23 shows the DIMM location on the main board. Slot 1, channel B is on the top; slot 3, channel A is on the bottom.



Note Slots 3A and 3B shown in Figure B-23 are not officially supported, because the processor (Intel i7 860) in this product supports only two channels of memory.

Memory upgrades are available from National Instruments under the following orderable part numbers:

- **781653-01**—1 × 2 GB DDR3 RAM for NI RMC-8354 (1 × 2 GB DIMM)
- **781654-01**—1 × 4 GB DDR3 RAM for NI RMC-8354 (1 × 4 GB DIMM)

Figure B-23. DIMM Location

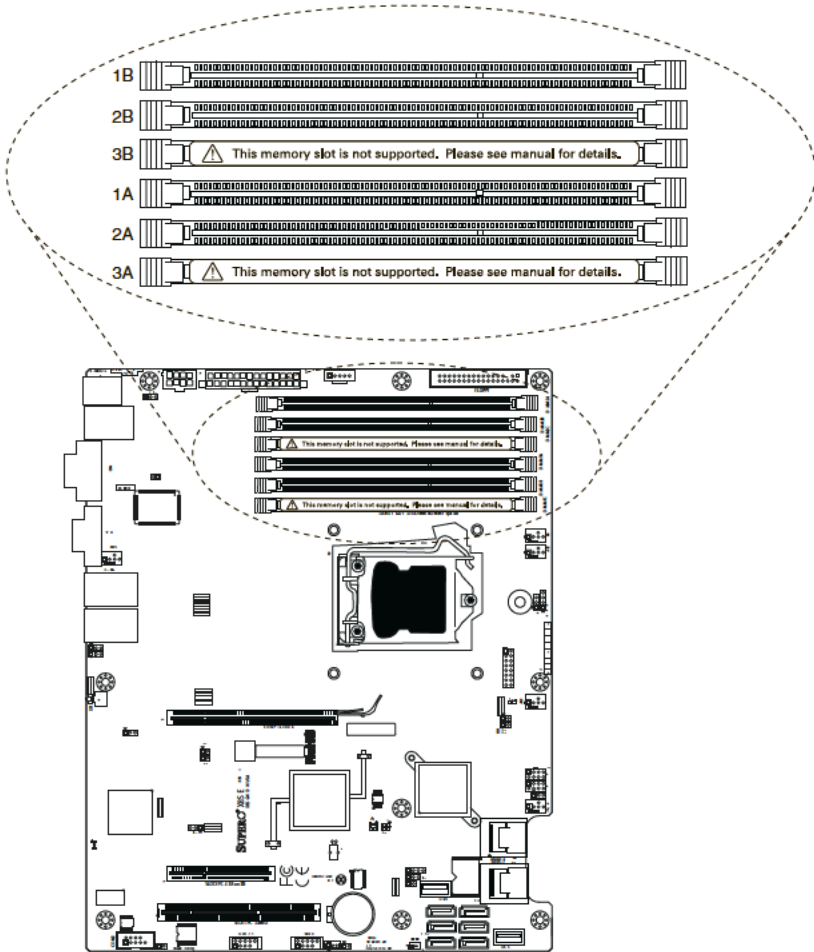

Memory Support

The NI RMC-8354 supports up to 16 GB of DDR3 ECC UDIMM (1333 MHz in 4 DIMM slots). Populating these DIMM modules with a pair of memory modules of the same type and size results in interleaved memory, which improves memory performance. Refer to the following table for DIMM module support guidelines.

Table B-12. DDR3 ECC/Unbuffered (UDIMM) Memory Support

ECC UDIMM	1 GB (x4 DRAM)	2 GB (x4 DRAM)
Single rank	Up to 4 GB (4 × 1 GB DIMM modules)	Up to 8 GB (4 × 2 GB DIMM modules)
Dual rank	Up to 8 GB (4 × 2 GB DIMM modules)	Up to 16 GB (4 × 4 GB DIMM modules)
Quad rank	Not supported	Not supported



Note For ECC UDIMMs, populate only slots 1A, 2A, 1B, and 2B. Refer to Figure B-23 for slot and channel locations.

Memory Population Guidelines

Refer to the following table when populating the NI RMC-8354.

Table B-13. DDR3 ECC UDIMM Memory

DIMM Slots per Channel	DIMMs Populated per Channel	DIMM Type	POR Speeds	Ranks per DIMM (Any Combination)
2	1	Unbuffered DDR3 ECC	1066 and 1333	Single rank, dual rank
2	2	Unbuffered DDR3 ECC	1066 and 1333	Single rank, dual rank



Note For ECC UDIMMs, populate only slot 1 and/or slot 2 per channel. Refer to Figure B-23 for slot and channel locations.



Note Due to memory allocation to system devices, the amount of memory that remains for operational use is reduced when you use 4 GB of RAM. The reduction in memory availability is disproportional.

For Microsoft Windows users, Microsoft implemented a design change in Windows XP with Service Pack 2 (SP2) and Windows Vista. This change is specific to the Physical Address Extension (PAE) mode behavior, which improves driver

compatibility. For more information, refer to the Microsoft knowledgebase article at <http://support.microsoft.com/kb/888137>.

Table B-14. Possible System Memory Allocation and Availability

System Device	Size	Physical Memory Available (4 GB Total System Memory)
Firmware hub flash memory (system BIOS)	1 MB	3.99
Local APIC	4 KB	3.99
Area reserved for the chipset	2 MB	3.99
I/O APIC (4 KB)	4 KB	3.99
PCI enumeration area 1	256 MB	3.76
PCI Express (256 MB)	256 MB	3.51
PCI enumeration area 2 (if needed) (aligned on 256 MB boundary)	512 MB	3.01
VGA memory	16 MB	2.85
TSEG	1 MB	2.84
Memory available to OS and other applications	—	2.84

Installing DDR Modules

Follow these steps to install DDR modules:

1. Press the cover release buttons on the top of the NI RMC-8354.
2. Push the cover backward to remove it.
3. Align the notch in the center of the DDR DIMM module with the key on the DIMM slot. Insert the module vertically into the slot and push it in until the pins are fully inserted, as shown below.

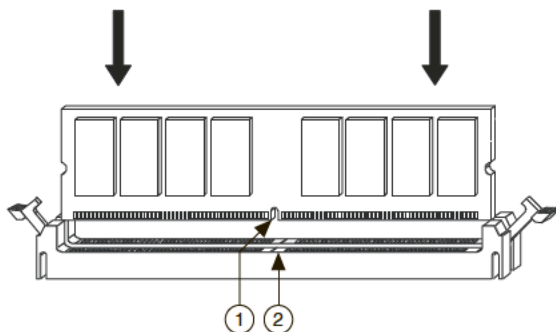

1 Notch

2 Key

4. When the module is fully inserted, the plastic clip at each side of the slot automatically closes, as shown below.

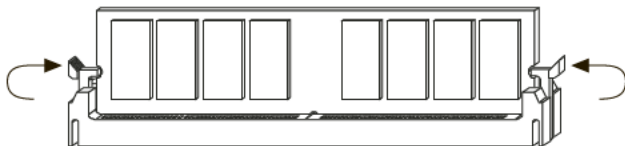

5. Replace the NI RMC-8354 cover by sliding the cover forward. Make sure the safety lock fits firmly.

Removing DDR Modules

Follow these steps to remove DDR modules:

1. Open the plastic clips on both sides of the module.
2. Remove the module from the slot.

Upgrading and Replacing Hard Disk Drives

Figure B-24 shows the NI RMC-8354 SATA connector locations.

Figure B-24. NI RMC-8354 SATA Connectors

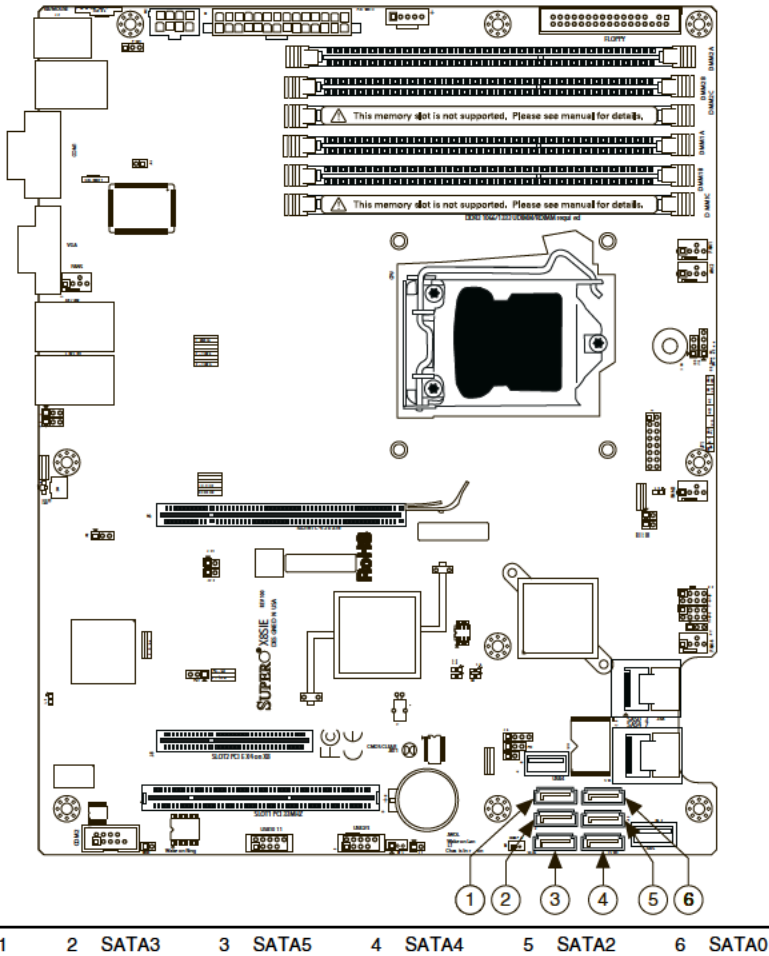

I-SATA Connectors: I-SATA0–I-SATA5

The ICH10R south bridge supports six Serial ATA connectors (I-SATA0–I-SATA5).

SATA connectors are high-speed Serial ATA interface ports. Each supports Serial ATA data rates of 300 MB/s. All connectors are fully compliant with Serial ATA 2.0 specifications. Each Serial ATA connector can connect to one hard disk.

Figure B-25 shows the I-SATA0–I-SATA5 connector.

Figure B-25. I-SATA0–I-SATA5 Connector

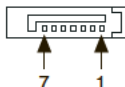

Hard Disk Installation



Caution Before removing or installing a hard disk drive, be sure the N1RMC-8354 is powered off and not connected to AC power.

Follow these steps to install a hard disk drive:

1. Press the release tab to release the SCA drive tray from its locking position.
2. Pull the SCA drive tray out from the chassis, as shown in Figure B-26.

Figure B-26. Removing SCA Drive Tray

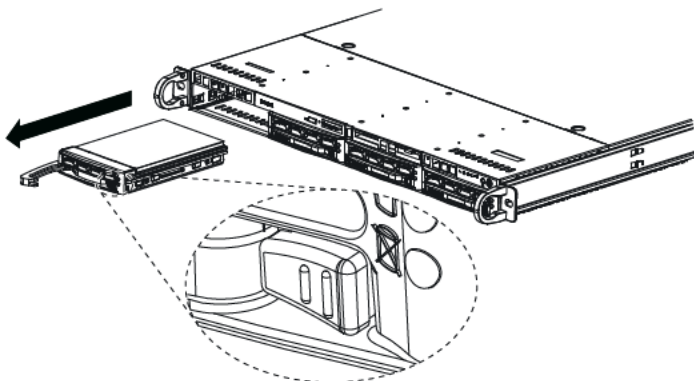

- Remove the two screws that attach to the sides of the dummy tray. Remove the tray, as shown in Figure B-27.

Figure B-27. Removing Dummy Tray

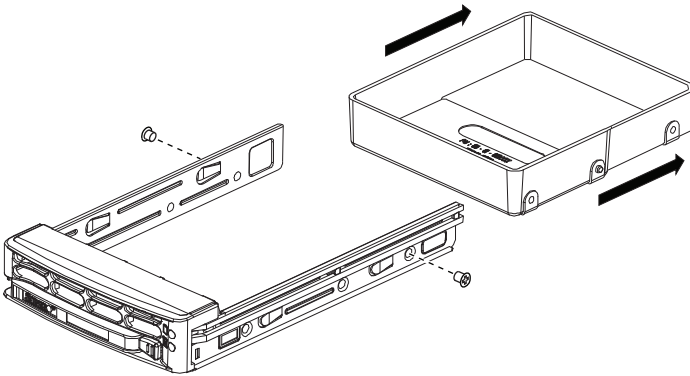

- Slide a hard disk drive into the SCA drive tray. Secure the drive to the tray with three screws on each side of the tray, as shown in Figure B-28.

Figure B-28. Sliding Hard Disk Drive into SCA Drive Tray

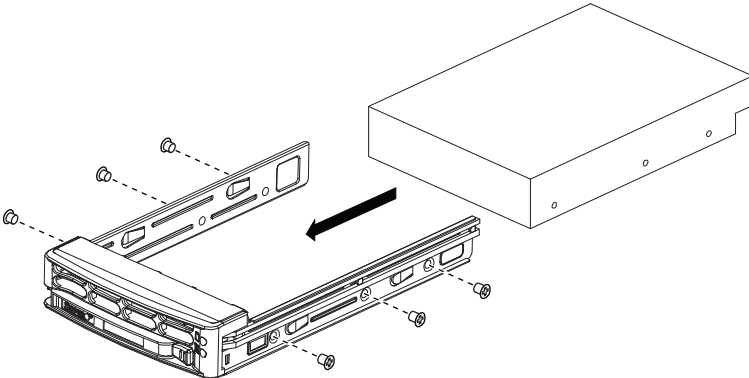

- Once the hard disk drive is securely installed in the SCA tray, you can reinstall the SCA drive tray in the chassis.

Installing a PCI Express Expansion Card

Follow these steps to install a PCI Express expansion card:

1. Locate the riser card bracket already installed in the NI RMC-8354 chassis.
2. Unscrew and lift the bracket from the chassis. (Depending on the PCI Express card size, removing the bracket may not be necessary to install a PCI Express expansion card.)
3. Remove the PCI slot filler bracket from the chassis.
4. Insert the PCI Express expansion card into the PCI Express slot on the riser card bracket.
5. Align the riser card bracket with the PCI Express slot on the chassis. (This may require “wiggling” the bracket to fit the bottom edge into the slot on the chassis.) If the bracket was removed from the chassis, carefully push down the bracket with even force on both sides until it is firmly seated in the slot.
6. Secure the PCI Express card bracket by closing the locking tab mechanism on the chassis.

Intel SATA RAID Utility for Intel ICH10R

This appendix describes the Intel SATA RAID utility for Intel ICH10R.

Intel RAID Configuration Utility

The Intel RAID Configuration utility is an embedded BIOS utility for creating, managing, and deleting arrays from the controller BIOS and initializing drives.

To run the Intel RAID Configuration utility, press <Ctrl-I> when the following message appears during system startup:

Press <CTRL-I> to enter Configuration Utility...

The main menu appears. To select an option from this or any menu, browse with the arrow keys to highlight an option and press <Enter>. In some cases, selecting an option displays another menu. To return to the previous menu at any time, press <Esc>.



Note The shipping default RAID mode is RAID 5.

Intel HostRAID Configurations

The following types of Intel HostRAID configurations are supported:

- **RAID0 (Data Striping)**—RAID0 writes data in parallel, interleaved (“striped”) sections between two hard drives. RAID0 doubles the data transfer rate (over a single hard drive) to enhance system performance. To use RAID0, two or more hard drive disks are required.
- **RAID1 (Data Mirroring)**—Use RAID1 to copy identical data from one disk drive to another. By doing so, a “mirror” of source data is created to enhance data security. To use RAID1, two or more hard drive disks are required, and the second drive must be the same size or larger than the first drive.
- **RAID10 (Striping and Mirroring)**—RAID0 and RAID1 modes are combined (without parity information) to maximize system performance and data security. To use RAID10, four or more hard drive disks are required.
- **RAID5**—Both data and parity information are striped and mirrored across three or more hard drives. To use RAID 5, three or more hard drive disks are required.

Configuring the AMI BIOS for SATA RAID Settings



Note Press during system bootup to enter the BIOS Setup Utility.

Follow these steps to configure the AMI BIOS for SATA RAID settings:

1. Use the arrow keys to select the **Advanced** menu from the menu bar and press <Enter> to enter the **Advanced** menu.
2. In the **Advanced** menu, scroll down to **IDE/SATA Configuration** and press <Enter> to enter the **IDE/SATA Configuration** submenu.
3. Once in the **IDE/SATA Configuration** submenu, scroll down to **Configure SATA#1** as and press <Enter>. The Options window displays.
4. From the Options window, select **RAID** and press <Enter>.
5. Press <Esc> to return to the previous menu. Use the arrow keys to select **Exit** from the menu bar at the top and press <Enter> to enter the **Exit** submenu.
6. From the **Exit** submenu, select **Save Changes and Exit** and press <Enter> to save the changes and exit the BIOS. The system reboots.
7. After the system exits from the BIOS Setup Utility, the system automatically reboots. When the system is rebooting, press <Ctrl> and <I> simultaneously to enter the Intel HostRAID utility.

Creating a RAID0 Volume

Follow these steps to create a RAID0 volume:

1. Select **Create RAID Volume** from the main menu and press <Enter>.
2. Specify a name for the RAID0 set and press <Tab> or <Enter> to go to the next field. (To select the previous menu, press <Esc>.)
3. When **RAID Level** is highlighted, use the up and down arrow keys to select **RAID0 (Stripe)** and press <Enter>.
4. When **Disks** is highlighted, press <Enter> to select the HDD to configure for RAID.
5. Use the up and down arrow keys to highlight a drive and press the space bar to select it. A triangle appears to confirm the drive selection.
6. When **Stripe Size** is highlighted, use the up and down arrow keys to select the stripe size for your RAID0 and press <Enter>.



Note Stripe size is 4–128 KB for RAID0. For a server, use a lower stripe size; for a multimedia system, use a higher stripe size. The default stripe size is 128 KB.

7. Press <Enter> when the **Create Volume** item is highlighted. A warning message displays, indicating that all data on the selected disks will be lost.
8. At the **Are you sure you want to create this volume (Y/N)** prompt, press <Y> to create the RAID volume or <N> to return to the **Create Volume** menu.

Creating a RAID1 Volume

Follow these steps to create a RAID1 volume:

1. Select **Create RAID Volume** from the main menu and press <Enter>.
2. Specify a name for the RAID1 set and press <Tab> or <Enter> to go to the next field. (To select the previous menu, press <Esc>.)
3. When **RAID Level** is highlighted, use the up and down arrow keys to select **RAID1 (Mirror)** and press <Enter>.
4. When **Disks** is highlighted, press <Enter> to select the HDD to configure for RAID.
5. Use the up and down arrow keys to highlight a drive and press the space bar to select it. A triangle appears to confirm the drive selection.
6. When **Capacity** is highlighted, press <Enter> to specify the disk capacity to configure for RAID1.
7. Press <Enter> when **Create Volume** is highlighted. A warning message displays, indicating that all data on the selected disks will be lost.
8. At the **Are you sure you want to create this volume (Y/N)** prompt, press <Y> to create the RAID volume or <N> to return to the **Create Volume** menu.

Creating a RAID10 (RAID1+ RAID0) Volume

Follow these steps to create a RAID10 (RAID1 + RAID0) volume:

1. Select **Create RAID Volume** from the main menu and press <Enter>. The Create Volume Menu screen appears.
2. Specify a name for the RAID10 set and press <Enter>.
3. When **RAID Level** is highlighted, use the up and down arrow keys to select **RAID10 (RAID1 + RAID0)** and press <Enter>.
4. When **Disk** is highlighted, press <Enter> to select the HDD to configure as RAID.
5. On the pop-up screen, use the up and down arrow keys to highlight a drive and press the space bar to select it. A triangle appears to confirm the drive selection.
6. When **Stripe Size** is highlighted, use the up and down arrow keys to select the stripe size of 4-128 KB for your RAID10 and press <Enter>. The default setting is 64 KB.



Note For a server, use a lower stripe size; for a multimedia system, use a higher stripe size.

7. When **RAID Capacity** is highlighted, enter your RAID volume capacity and press <Enter>. The default setting is the maximum capacity allowed.
8. Press <Enter> when the **Create Volume** item is highlighted. A warning message displays, indicating that all data on the selected disks will be lost.
9. At the **Are you sure you want to create this volume (Y/N)** prompt, press <Y> to create the RAID volume or <N> to return to the **Create Volume** menu.

Creating a RAID5 Set (Parity)

Follow these steps to create a RAID5 set:

1. Select **Create RAID Volume** from the main menu and press <Enter>. The **Create Volume** menu screen appears.
2. Specify a name for the RAID5 set and press <Enter>.
3. When **RAID Level** is highlighted, use the up and down arrow keys to select **RAID5 (Parity)** and press <Enter>.
4. When **Disk** is highlighted, press <Enter> to select the HDD to configure as RAID.
5. On the pop-up screen, use the up and down arrow keys to highlight a drive and press the space bar to select it. A triangle appears to confirm the selection.
6. Use the up and down arrow keys to select the stripe size of 4-128 KB for RAID5 and press <Enter>.



Note For a server, use a lower stripe size; for a multimedia system, use a higher stripe size. The default stripe size is 128 KB.

7. Enter your desired RAID capacity and press <Enter> when the capacity item is highlighted. The default setting is the maximum capacity allowed.
8. Press <Enter> when **Create Volume** is highlighted. A warning message displays, indicating that all data on the selected disks will be lost.
9. At the **Are you sure you want to create this volume (Y/N)** prompt, press <Y> to create the RAID volume or <N> to return to the **Create Volume** menu.

Recovery

Use this feature to create the recovery volume by copying data from a designated master drive to a designated recovery drive.



Note A recovery drive is a backup drive to store data copied from the original (master) drive. A master drive is the original drive containing the source files to be copied to the recovery drive.

Follow these steps to create a recovery drive:

1. Select **Create RAID Volume** from the main menu and press <Enter>. The **Create Volume Menu** screen appears.
2. Specify a name for the recovery disk drive and press <Enter>.
3. When **RAID Level** is highlighted, use the up and down arrow keys to select **Recovery** and press <Enter>.
4. When **Select Disks** is highlighted, press <Enter> to select the HDD to create the recovery volume.

5. On the **Select Disks** screen, use the up and down arrow keys to select a drive to use as your master drive and press <Tab> to configure it as your master drive. Use the arrow keys to select your recovery drive and press the space bar to configure it. Press <Enter> to complete the disk selection.
6. When **RAID Capacity** is highlighted, enter your RAID volume capacity and press <Enter>. The default setting is the maximum capacity allowed.
7. When **Sync** is highlighted, use the up and down arrow keys to select the **Continuous** or **On Request** update policy. If you select **Continuous**, data on the master drive is copied to the recovery drive automatically as long as both drives are connected to the system. If you select **On Request**, data on the master drive is copied to the recovery drive when you request it.
8. Press <Enter> when the **Create Volume** item is highlighted. A warning message displays, indicating that all data on the selected disks will be lost.
9. At the **Are you sure you want to create this volume (Y/N)** prompt, press <Y> to create the RAID volume or <N> to return to the **Create Volume** menu without making changes.

Deleting a RAID Volume



Caution Be sure to back up your data before deleting a RAID set. You will lose all data on the drives when deleting a RAID set. You also will lose the recovery image.

Follow these steps to delete a RAID volume:

1. From the main menu, select **Delete RAID Volume** and press <Enter>.
2. Use the up and down arrow keys to select the RAID set to delete and press . A warning message displays.
3. At the **Are you sure you want to delete this volume (Y/N)** prompt, press <Y> to delete the RAID volume or <N> to return to the **Delete Volume** menu.

Resetting to Non-RAID



Caution Be careful when you reset a RAID volume HDD to a non-RAID HDD. Resetting a RAID HDD or RAID volume reformats the disk drive and deletes the internal RAID structure and contents.

Follow these steps to reset a RAID volume HDD to non-RAID:

1. From the main menu, select **Reset Disks to Non-RAID** and press <Enter>.
2. Use the up and down arrow keys to highlight the RAID set drive to reset and press the space bar to select it.
3. Press <Enter> to reset the RAID set drive. A warning message displays.
4. Press <Y> to reset the drive or <N> to return to the main menu.

Recovery Volume Options



Caution A recovery drive is a backup drive to store data copied from the original (master) drive. A master drive is the original drive containing the source files to be copied to the recovery drive.

Follow these steps to select a recovery volume option:

1. From the main menu, select **Recovery Volume Options**.
2. When **Recovery Volume Options** is highlighted, press <Enter>.
3. To boot from a recovery disk only, select **Enable Only Recovery Disk** and press <Enter>.



Caution If a recovery disk is available, its RAID volume recovery support is enabled, and the master disk is disabled.

4. To boot from the master disk that contains the original data sources only, select **Enable Only Master Disk** and press <Enter>.



Caution If a master disk is available, its RAID volume recovery support is enabled, and the recovery disk is disabled. Any change in steps 3 or 4 stops automatic synchronization between the master and recovery drives.

5. Press <Esc> to return to the main menu.

Exiting the Intel Matrix Storage Manager Utility

Follow these steps to exit the Intel Matrix Storage Manager utility:

1. From the main menu, select **Exit** and press <Enter>.
2. A warning message appears. At the prompt, press <Y> to delete the drive or <N> to return to the main menu.

NI Services

National Instruments provides global services and support as part of our commitment to your success. Take advantage of product services in addition to training and certification programs that meet your needs during each phase of the application life cycle; from planning and development through deployment and ongoing maintenance.

To get started, register your product at ni.com/myproducts.

As a registered NI product user, you are entitled to the following benefits:

- Access to applicable product services.
- Easier product management with an online account.
- Receive critical part notifications, software updates, and service expirations.

Log in to your National Instruments ni.com User Profile to get personalized access to your services.

Services and Resources

- **Maintenance and Hardware Services**—NI helps you identify your systems' accuracy and reliability requirements and provides warranty, sparing, and calibration services to help you maintain accuracy and minimize downtime over the life of your system. Visit ni.com/services for more information.
 - **Warranty and Repair**—All NI hardware features a one-year standard warranty that is extendable up to five years. NI offers repair services performed in a timely manner by highly trained factory technicians using only original parts at a National Instruments service center.
 - **Calibration**—Through regular calibration, you can quantify and improve the measurement performance of an instrument. NI provides state-of-the-art calibration services. If your product supports calibration, you can obtain the calibration certificate for your product at ni.com/calibration.
- **System Integration**—If you have time constraints, limited in-house technical resources, or other project challenges, National Instruments Alliance Partner members can help. To learn more, call your local NI office or visit ni.com/alliance.

- **Training and Certification**—The NI training and certification program is the most effective way to increase application development proficiency and productivity. Visit ni.com/training for more information.
 - The Skills Guide assists you in identifying the proficiency requirements of your current application and gives you options for obtaining those skills consistent with your time and budget constraints and personal learning preferences. Visit ni.com/skills-guide to see these custom paths.
 - NI offers courses in several languages and formats including instructor-led classes at facilities worldwide, courses on-site at your facility, and online courses to serve your individual needs.
- **Technical Support**—Support at ni.com/support includes the following resources:
 - **Self-Help Technical Resources**—Visit ni.com/support for software drivers and updates, a searchable KnowledgeBase, product manuals, step-by-step troubleshooting wizards, thousands of example programs, tutorials, application notes, instrument drivers, and so on. Registered users also receive access to the NI Discussion Forums at ni.com/forums. NI Applications Engineers make sure every question submitted online receives an answer.
 - **Software Support Service Membership**—The Standard Service Program (SSP) is a renewable one-year subscription included with almost every NI software product, including NI Developer Suite. This program entitles members to direct access to NI Applications Engineers through phone and email for one-to-one technical support, as well as exclusive access to online training modules at ni.com/self-paced-training. NI also offers flexible extended contract options that guarantee your SSP benefits are available without interruption for as long as you need them. Visit ni.com/ssp for more information.
- **Declaration of Conformity (DoC)**—A DoC is our claim of compliance with the Council of the European Communities using the manufacturer’s declaration of conformity. This system affords the user protection for electromagnetic compatibility (EMC) and product safety. You can obtain the DoC for your product by visiting ni.com/certification.

For information about other technical support options in your area, visit ni.com/services, or contact your local office at ni.com/contact.

You also can visit the Worldwide Offices section of ni.com/niglobal to access the branch office websites, which provide up-to-date contact information, support phone numbers, email addresses, and current events.

Glossary

Symbol	Prefix	Value
p	pico	10^{-12}
n	nano	10^{-9}
μ	micro	10^{-6}
m	milli	10^{-3}
k	kilo	10^3
M	mega	10^6
G	giga	10^9
T	tera	10^{12}

Symbols

° Degrees

W Ohms

% Percent

A

A Amperes.

A/D Analog-to-digital. Most often used as *A/D converter*.

AC Alternating Current.

ACPI Advanced Configuration and Power Management Interface.

ANSI American National Standards Institute.

API Application Programming Interface—A standardized set of subroutines or functions along with the parameters that a program can call.

APIC Advanced Programmable Interrupt Controller.

Glossary

ASCII	American Standard Code for Information Exchange.
ASIC	Application-Specific Integrated Circuit.
ATA	The specification formulated in the 1980s that defines the IDE drive interface.

B

B	Bytes.
BIOS	Basic Input/Output System—BIOS functions are the fundamental level of any PC or compatible computer. BIOS functions embody the basic operations needed for successful use of the computer's hardware resources.

C

C	Celsius.
CAS	Column Address Strobe.
CMOS	Complementary Metal Oxide Semiconductor—A process used in making chips.
COM	Communications port.
CPU	Central Processing Unit.
CSA	Carrier Serving Area.

D

D/A	Digital-to-analog—Most often used as an abbreviation for a D/A converter (also known as DAC).
DC	Direct Current.
DDR	Double Data Rate.
DIMM	Dual In-line Memory Module.

DMA	Direct Memory Access—A method by which data is transferred between devices and internal memory without intervention of the central processing unit.
DMI	Desktop Management Interface.
DRAM	Dynamic RAM (Random Access Memory)—Storage that the computer must refresh at frequent intervals.

E

ECC	Error-Correcting Code.
EDO RAM	Extended Data Output RAM—A type of random access memory (RAM) chip that improves the time to read from memory on faster microprocessors such as the Intel Pentium.
EEPROM	Electrically Erasable Programmable Read Only Memory.
EMC	Electromagnetic Compatibility.
EMI	Electromagnetic Interference.
EPP	Enhanced Parallel Port.

F

FCC	Federal Communications Commission.
-----	------------------------------------

G

GB	Gigabytes of memory.
GPB	General Purpose Interface Bus (IEEE 488).

H

HDD	Hard Disk Drive.
Hz	Hertz; cycles per second.

I

I/O	Input/output—The techniques, media, and devices used to achieve communication between machines and users.
IDE	Integrated Drive Electronics—Hard disk and built-in controller.
IEEE	Institute of Electrical and Electronics Engineers.
IRQ*	Interrupt signal.
ISA	Industry Standard Architecture—The original PC bus architecture, specifically the 16-bit AT bus.

K

KB	Kilobytes of memory.
----	----------------------

L

LAN	Local Area Network—Communications network that serves users within a confined geographical area. It is made up of servers, workstations, a network operating system, and a communications link.
LCD	Liquid Crystal Display—A display technology using polarizing filters and liquid crystal cells.
LED	Light-emitting diode.

M

MAX	Measurement & Automation Explorer.
MB	Megabytes of memory.
MPS	Multiprocessor Specification.
MTBF	Mean Time Between Failure.
MTTR	Mean Time to Repair.
MXI	Multisystem eXtension Interface.

N

NI-DAQ	The National Instruments software for data acquisition instruments.
NI-VISA	The National Instruments implementation of the VISA standard—An interface-independent software that provides a unified programming interface for VXI, GPIB, and serial instruments.

P

PCI	Peripheral Component Interconnect. The PCI bus is a high-performance 32-bit or 64-bit bus with multiplexed address and data lines.
PEF	Platform Event Filter.
PIO	Programmed Input/Output.
POSC	Power On Self Configuration.
POST	Power On Self Test.
PXI	PCI eXtensions for Instrumentation—An open implementation of CompactPCI that adds electrical features that meet the high-performance requirements of instrumentation applications by providing triggering, local buses, and system clock capabilities. PXI also offers two-way interoperability with CompactPCI products.

R

RAM	Random Access Memory—The computer's primary workspace.
RAS	Row Address Strobe.
RMS	Root Mean Squared.
RTC	Real Time Clock—An electronic circuit that maintains the time of day and also can provide timing signals for timesharing operations.

S

SATA	Serial-ATA. <i>See also</i> ATA .
SCSI	Small Computer System Interface.
SDRAM	A form of dynamic RAM memory that is about 20% faster than EDO RAM. SDRAM interleaves two or more internal memory arrays so that while one array is being accessed, the next one is being prepared for access. SDRAM-II is a faster version of SDRAM technology.
SO-DIMM	Small Outline Dual In-line Memory Module.
SPD	Serial Presence Detect EEPROM.
SRAM	Static RAM—A memory chip that requires power to hold its content. It does not require refresh circuitry as a dynamic RAM chip, but it does take up more space and uses more power.

U

UDMA	Ultra Direct Memory Access. <i>See also</i> DMA .
USB	Universal Serial Bus.

V

V	Volts.
VGA	Video Graphics Array—The minimum video display standard for all PCs.
VISA	Virtual Instrument Software Architecture—A single interface library for controlling GPIB, VXI, RS232, and other types of instruments. VISA has been standardized by the <i>VXI Plug&Play</i> Systems Alliance.
VME	Versa Module Eurocard.
VXI	VME eXtensions for Instrumentation.

W

W Watts.

WDT Watchdog Timer.

Index

Numerics

32-Bit Data Transfer BIOS setup option, 2-10

A

AC power cables (table), 1-2

acoustic emissions specifications, A-3

ACPI APIC Support BIOS setup option, 2-15

ACPI Aware O/S BIOS setup option, 2-15

ACPI Configuration BIOS setup menu, 2-15

ACPI Version Features BIOS setup option, 2-16

Active Processor Cores, 2-6

Active State Power Management BIOS setup option, 2-7

AddOn ROM Display Mode BIOS setup option, 2-4

Adjacent Cache Line Prefetch BIOS setup option, 2-6

Advanced Chipset Control BIOS setup menu, 2-7

advanced setup configurations, 2-4

alarm reset header (JAR), B-14
pinout (figure), B-14
signals (table), B-14

AMI BIOS for SATA RAID settings, configuring, C-2

APIC ACPI SCI IRQ BIOS setup option, 2-15

B

BIOS

advanced setup configurations, 2-4

boot settings, 2-17

checking settings, 4-1

exit options, 2-18

flashing new BIOS, 4-3

main BIOS setup menu, 2-4

POST error beep codes, 2-18

security settings, 2-16
setup, 2-3

BIOS setup menu, 2-4

BIOS setup option, 2-6

Block (Multi-Sector Transfer) BIOS setup option, 2-9

BMC jumper (JPB) settings, B-5

Boot Device Priority BIOS setup option, 2-17

Boot Feature BIOS setup menu, 2-4

Boot Graphics Adapter Priority BIOS setup option, 2-11

boot options, configuring controller, 4-2

Boot Sector Virus Protection BIOS setup option, 2-17

boot settings, 2-17

Bootup Num-Lock BIOS setup option, 2-4

C

C1 Auto Demotion BIOS setup option, 2-7

C1E Support BIOS setup option, 2-7

C3 Auto Demotion BIOS setup option, 2-7
cables, power (table), 1-2

CE compliance specifications, A-4

Change Supervisor Password BIOS setup option, 2-16

Change User Password BIOS setup option, 2-17

chassis intrusion switch connector (JL1), B-12
pinout (figure), B-12
signals (table), B-12

chassis, installing into rack (figure), 2-24

clear CMOS jumper (JBT1) settings, B-4

Clear Event Log BIOS setup option, 2-16

Clear NVRAM BIOS setup option, 2-10

Clear User Password BIOS setup option, 2-17

Clock Spread Spectrum BIOS setup option, 2-5

common configuration questions, 4-1

boot options, 4-2

chassis configuration, 4-2

general questions, 4-1

upgrade information, 4-3

Configure SATA as BIOS setup option, 2-8

connector locations (figure), B-6

connectors

- alarm reset header (JAR), B-14
 - chassis intrusion switch connector (JL1), B-12
 - Ethernet connector and signals, 3-6
 - fan power connectors (Fan1 to Fan5), B-9
 - floppy connector, B-7
 - front panel connector (JF1), B-10
 - front USB connectors (USB2/3 and USB10/11), B-13
 - onboard power LED header (JLED), B-10
 - PCI Express slot, B-14
 - peripheral expansion overview (table), 3-1
 - power supply connector (JPI2C), B-7
 - PS/2 connector and signals, 3-2
 - serial connector and signals, 3-4
 - T-SGPIO0/1 headers, B-11
 - Universal Serial Bus (USB) connector and signals, 3-3
 - VGA connector and signals, 3-4
 - Wake-On-LAN header (JWOL), B-12
 - Wake-On-Ring header (JWOR), B-13
- cooling, air cooling of NI RMC-8354, 2-2
- CPU Overheat Alarm BIOS setup option, 2-13
- CPU Ratio BIOS setup option, 2-5
- CPU specifications, A-2
- CPU Temperature BIOS setup option, 2-13
- C-State Package Limit Setting BIOS setup option, 2-7

D

DDR DIMMs

- from National Instruments (note), 1-5
 - installing, B-18
 - memory population guidelines, B-16
 - memory support, B-16
 - removing, B-18
- DIMM location (figure), B-15
- Discard Changes and Exit BIOS setup option, 2-18
- Discard Changes BIOS setup option, 2-18

- DMA Mode BIOS setup option, 2-9
- documentation, related documentation, *xi*
- drivers, obtaining latest drivers, 4-3

E

- electrical specifications, A-1
- electromagnetic compatibility specifications, A-4
- environmental management specifications, A-4
- environmental specifications, A-3
- Ethernet connector and signals, 3-6
 - location and pinout (figure), 3-6
 - signals (table), 3-6
- Ethernet, overview (table), 3-1
- Event Log Configuration menu BIOS setup option, 2-16
- Execute Disable Bit Capability BIOS setup option, 2-6
- exit options, 2-18

F

- factory test jumper (JPT1) settings, B-4
- fan power connectors (Fan1 to Fan5), B-9
 - pinout (figure), B-9
 - signals (table), B-9
- Fan Speed Control Modes BIOS setup option, 2-14
- Fan1 ~ Fan 6 Reading BIOS setup option, 2-15
- Floppy A BIOS setup option, 2-8
- floppy connector, B-7
 - pinout (figure), B-7
 - signals (table), B-8
- floppy drive, using external floppy drive, 4-3
- Flow Control BIOS setup option, 2-12
- front panel connector (JF1), B-10
 - pinout (figure), B-10
 - signals (table), B-10
- front USB connectors (USB2/3 and USB10/11)
 - pinout (figure), B-13
 - signals (table), B-13

G

GLAN1/GLAN2 jumper (JPL1/JPL2)
 settings, B-5
 ground, connecting, 2-3

H

hard disk drives
 specifications, A-2
 upgrading and replacing, B-19
 installation, B-20
 I-SATA connectors supported,
 I-SATA0 to I-SATA5, B-20
 Hard Disk Drives BIOS setup option, 2-17
 Hardware Health Configuration BIOS setup
 menu, 2-13
 Hardware Prefetcher BIOS setup option, 2-6
 Headless Mode BIOS setup option, 2-16
 High-Performance Event Timer BIOS setup
 option, 2-15
 Hit “Del” Message Display BIOS setup
 option, 2-5

I

IDE controller, using SCSI hard drive in
 addition, 4-1
 IDE Detect Timeout (sec) BIOS setup
 option, 2-8
 inner slides
 installing (figure), 2-20
 installing into outer slides (figure), 2-23
 installation, 2-2
 configuration and operation
 connecting safety ground, 2-3
 site considerations, 2-2
 testing power up, 2-3
 unpacking the NI RMC-8354, 1-1
 installing a PCI Express expansion card, B-22
 installing hard disk drives, B-20
 installing NI RMC-8354, 2-1
 Intel C-State Tech BIOS setup option, 2-7
 Intel EIST Technology BIOS setup
 option, 2-6
 Intel HostRAID configurations, C-1

Intel Matrix Storage Manager utility,
 exiting, C-6
 Intel RAID Configuration utility, C-1
 configuring AMI BIOSs for SATA RAID
 settings, C-2
 creating recovery volume, C-4
 creating volumes
 RAID0, C-2
 RAID1, C-3
 RAID10, C-3
 RAID5 set, C-4
 deleting a RAID volume, C-5
 exiting Intel Matrix Storage Manager
 utility, C-6
 Intel HostRAID configurations, C-1
 recovery volume options, C-6
 resetting a RAID HDD, C-5
 resetting to non-RAID, C-5
 Intel SATA RAID utility for Intel
 ICH710R, C-1
 Intel Turbo Boost Technology BIOS setup
 option, 2-7
 Intel Virtualization Technology BIOS setup
 option, 2-6
 Intel VT-d BIOS setup option, 2-7
 Interrupt 19 Capture BIOS setup option, 2-5
 I-SATA connectors, I-SATA0 to
 I-SATA5, B-20
 I-SATA0 to I-SATA5 connector (figure), B-20

J

jumper locations (figure), B-3
 jumper settings, B-3
 BMC jumper (JPB), B-5
 clear CMOS jumper (JBT1), B-4
 factory test jumper (JPT1), B-4
 GLAN1/GLAN2 (JPL1/JPL2), B-5
 SMBus to PCI/PCI-Express slots
 (JI²C1/JI²C2), B-5
 USB wakeup (JPUSB1), B-4
 VGA connector (JPG1), B-5

K

- key features, 1-2
- keyboard, overview (table), 3-1
- kit contents, 1-1

L

- LabVIEW, 1-5
- LabWindows/CVI, 1-5
- LBA/Large Mode BIOS setup option, 2-9
- LEDs, front panel, 4-1
- Legacy USB Support BIOS setup option, 2-8
- Load Fail-Safe Defaults BIOS setup option, 2-18
- Load Onboard LAN1 Option ROM BIOS setup option, 2-11
- Load Onboard LAN2 Option ROM BIOS setup option, 2-11
- Load Optimal Defaults BIOS setup option, 2-18

M

- mainboard specifications, A-1
- maintenance, cleaning, exterior, 2-26
- Mark All Events as Read BIOS setup option, 2-16
- mating connector
 - Ethernet, 3-6
 - serial, 3-4
 - USB, 3-3
 - VGA, 3-4
- Measurement Studio, 1-5
- mechanical specifications, A-2
- memory
 - specifications, A-2
 - upgrading, 1-5, B-14
 - installing DDR modules, B-18
 - removing DDR modules, B-18
- memory population guidelines (table), B-16
- Memory Remap Feature BIOS setup option, 2-7
- memory support (table), B-16
- modular instruments, 1-6
- MPS and ACPI MADT Ordering BIOS setup option, 2-6

N

- National Instruments, software, 1-5
- NI RMC-8354
 - BIOS setup, 2-3
 - boot options, 4-2
 - chassis configuration, 4-2
 - chassis cooling considerations, 2-2
 - common configuration questions, 4-1
 - configuration, hardware, B-1
 - connector locations (figure), B-6
 - connectors, 3-1
 - alarm reset header (JAR), B-14
 - chassis intrusion switch connector (JL1), B-12
 - Ethernet, 3-6
 - fan power connectors (Fan1 to Fan5), B-9
 - floppy connector, B-7
 - front panel connector (JF1), B-10
 - front USB connectors (USB2/3 and USB10/11), B-13
 - onboard power LED header (JLED), B-10
 - PCI Express slot, B-14
 - power supply connector (JPI2C), B-7
 - PS/2 connector and signals, 3-2
 - serial connector and signals, 3-4
 - T-SGPIO0/1 headers, B-11
 - Universal Serial Bus (USB) connector and signals, 3-3
 - VGA, 3-4
 - Wake-On-LAN header (JWOL), B-12
 - Wake-On-Ring header (JWOR), B-13
 - description, 1-4
 - DIMM location (figure), B-15
 - front panel LEDs, 4-1
 - hardware configuration, B-1
 - installation, 2-1, 2-2
 - installing a PCI Express expansion card, B-22
 - jumper locations (figure), B-3
 - jumper settings, B-3

- key features, 1-2
- memory upgrades, 1-5
- optional equipment, 1-5
- OS reinstallation and recovery, 2-25
- overview, 1-2
- peripheral expansion overview (table), 3-1
- power source, connecting to, 2-3
- rack mounting, 2-19
- safety and caution notices, 2-1
- safety ground, connecting, 2-3
- SATA connector locations (figure), B-19
- software, 1-5
- troubleshooting, 5-1
- upgrade information, 4-3
- upgrading and replacing hard disk drives, B-19
- upgrading memory, B-14
- upgrading RAM, 4-3
- USB floppy disk drive, 1-5
 - using with PXI chassis, 4-2
- NI-DAQmx, 1-6
- NI-VISA, 1-6
- Non-RAID, resetting to, C-5

O

- Onboard Floppy Controller BIOS setup option, 2-12
- onboard power LED header (JLED), B-10
 - pinout (figure), B-10
 - signals (table), B-10
- optional equipment, 1-5
 - memory upgrades, 1-5
 - USB floppy disk drive, 1-5
- OS reinstallation and recovery, 2-25
- outer slide assemblies, assembling (figure), 2-21
- overview, 1-2

P

- Password Check BIOS setup option, 2-17
- PCH RAID CodeBase BIOS setup option, 2-8
- PCI Express expansion card, installing, B-22
- PCI Express slot, B-14
- PCI Express Slot pinout (figure), B-14

- PCI IDE Bus Master BIOS setup option, 2-11
- PCI Latency Timer BIOS setup option, 2-11
- PCI Slot 1, PCIe Slot 2 & 6 OPROM BIOS setup option, 2-11
- PCI/PnP Configuration BIOS setup menu, 2-10
- PCIe Error Log BIOS setup option, 2-16
- PCIe I/O Performance BIOS setup option, 2-11
- peripheral expansion overview (table), 3-1
- PIO Mode BIOS setup option, 2-9
- Plug & Play OS BIOS setup option, 2-11
- POST error beep codes, 2-18
- Power Button Mode BIOS setup option, 2-5
- power cables (table), 1-2
- power supply connector (JPI2C), B-7
 - pinout (figure), B-7
 - signals (table), B-7
- power supply, connecting to, 2-3
- power up, testing, 2-3
- Processor and Clock Options BIOS setup menu, 2-5
- PS/2
 - connector and signals, 3-2
 - connector location and pinout (figure), 3-2
 - connector signals (table), 3-2
- PS/2 Mouse Support BIOS setup option, 2-4
- `pxisys.ini` file, 4-2

Q

- Quick Boot BIOS setup option, 2-4
- Quiet Boot BIOS setup option, 2-4

R

- rack mounting, 2-19
 - assembling outer slide assemblies, 2-21
 - installing chassis into rack, 2-23
 - installing inner slides, 2-20
 - installing outer slide assemblies into rack, 2-22
- RAID HDD, resetting, C-5
- RAID volume, deleting, C-5
- RAID0 volume, creating, C-2
- RAID1 volume, creating, C-3

RAID10 volume, creating, C-3
 RAID5 set, creating, C-4
 RAM
 DDR DIMMs from National Instruments
 (note), 1-5
 upgrading, 4-3
 rear panel connectors, 3-1
 Recoverable POST Error Beep Codes BIOS
 setup option, 2-19
 recovery volume
 creating, C-4
 options, C-6
 Redirection After BIOS POST BIOS setup
 option, 2-12
 related documentation, *xi*
 Remote Access BIOS setup option, 2-12
 Remote Access Configuration BIOS setup
 menu, 2-12
 Removable Drives BIOS setup option, 2-18
 replacing hard disk drives, B-19
 Restore on AC Power Loss BIOS setup
 option, 2-5
 Retry Boot Devices BIOS setup option, 2-18
 ROM Scan Ordering BIOS setup option, 2-11
 Route Port 80h Cycles to BIOS setup
 option, 2-8

S

safety and caution notices, 2-1
 safety ground, connecting, 2-3
 safety specifications, A-3
 SATA 0 ~ 5r BIOS setup option, 2-9
 SATA connector locations (figure), B-19
 SATA RAID utility, C-1
 SATA/Floppy Configuration menu BIOS
 setup option, 2-8
 SATA#1 Configuration BIOS setup
 option, 2-8
 SATA#2 Configuration BIOS setup
 option, 2-8
 Save Changes and Exit BIOS setup
 option, 2-18
 security settings, 2-16

serial connector, 3-4
 connector locations and pinout
 (figure), 3-4
 connector signals (table), 3-4
 Serial Port Mode BIOS setup option, 2-12
 Serial Port Number BIOS setup option, 2-12
 Serial Port1 Address/Serial Port2 Address
 BIOS setup option, 2-12
 serial ports, 3-1
 See also COM1 and COM2 connectors
 Simultaneous Multithreading BIOS setup
 option, 2-6
 slide assemblies, installing into rack
 (figure), 2-22
 SMART for Hard Disk Drives BIOS setup
 option, 2-10
 SMBus to PCI/PCI-Express slots jumper
 J1²C1/J1²C2) settings, B-5
 software
 See also drivers
 LabVIEW, 1-5
 LabWindows/CVI, 1-5
 Measurement Studio, 1-5
 National Instruments software, 1-5
 NI-DAQmx, 1-6
 NI-VISA, 1-6
 specifications
 acoustic emissions, A-3
 CE compliance, A-4
 CPU, A-2
 electrical, A-1
 electromagnetic compatibility, A-4
 environmental, A-3
 environmental management, A-4
 hard disk drive, A-2
 mainboard, A-1
 mechanical, A-2
 memory, A-2
 safety, A-3
 Sredir Memory Display Delay BIOS setup
 option, 2-13
 Super IO Device Configuration menu BIOS
 setup option, 2-12
 Supervisor Password BIOS setup option, 2-16

system memory allocation and availability
(table), B-17
System Temperature BIOS setup option, 2-13

T

Terminal Type BIOS setup option, 2-12
testing power up, 2-3
troubleshooting
 controller does not boot, 5-1
 damaged module, 5-2
 video display, 5-2
T-SGPIO0/1 headers, B-11
 pinout (figure), B-11
 signals (table), B-11
Type BIOS setup option, 2-9

U

Universal Serial Bus (USB), 3-1
 connector location and pinout
 (figure), 3-3
 connector signals (table), 3-3
 connectors and signals, 3-3
 overview (table), 3-1
unpacking the NI RMC-8354, 1-1
upgrading hard disk drives, B-19
upgrading memory, B-14
 installing DDR modules, B-18
 memory population guidelines, B-16
 memory support, B-16
 removing DDR modules, B-18
USB floppy disk drive, 1-5
USB Functions BIOS setup option, 2-8
USB wakeup (JPUSB1) jumper settings, B-4
User Access Level BIOS setup option, 2-17
User Password BIOS setup option, 2-16

V

VGA

 connector and signals, 3-4
 connector signals (table), 3-5
 location and pinout (figure), 3-5
 overview (table), 3-1
VGA connector (JPG1) jumper settings, B-5
video, 3-1
 See also VGA
View Event Log BIOS setup option, 2-16
VT-UTF8 Combo Key Support BIOS setup
 option, 2-13

W

Wait For “F1” If Error BIOS setup option, 2-5
Wake-On-LAN header (JWOL), B-12
 pinout (figure), B-12
 signals (table), B-12
Wake-On-Ring header (JWOR), B-13
 pinout (figure), B-13
 signals (table), B-13
Watch Dog Function BIOS setup option, 2-5