

**Anritsu** Advancing beyond

# Radio Communication Analyzer

## MT8821C

30 MHz to 3.8 GHz

3.8 GHz to 6.0 GHz (Option)



# Tomorrow's Wireless Test Capability Today

The Radio Communication Analyzer MT8821C is designed for R&D into mobile devices (User Equipment: UE), such as smartphones, tablets and M2M/IoT modules. It builds on the technologies of its popular predecessor, the MT8820C used worldwide by UE and chipset vendors. It operates as a base station simulator using standard call processing sequences compliant with test standards to support a versatile test lineup, starting with RF tests.



## More Efficient RF Testing Supporting LTE-Advanced UE Measurement

With the introduction of LTE-Advanced, wireless communications are starting to use Carrier Aggregation (CA) technology offering continuing extendibility to wider bandwidths and more frequency bands. Additionally, adoption of the latest in faster communications technologies, such as 2x2 and 4x4 Multiple Input Multiple Output (MIMO) to improve frequency usage efficiency, means that measurement technologies are also becoming increasingly complex.

**3.2 Gbps PHY TPWT** Supports physical layer downlink maximum throughput 3.2 Gbps measurement\*

**8 CA 4x4 MIMO** Supports LTE-Advanced 8CC 4x4 MIMO tests

**4 CA 2x2 MIMO** Supports LTE-Advanced 4CC 2x2 MIMO tests in one unit

**160 MHz BW** 160 MHz wide frequency bandwidth (Generator/Analyzer) supports evolving UE technologies

**Cellular IoT** Support RF measurement and IP data transfer test of LTE Category M1 and NB-IoT Category NB1,2

**LAA** Supports tests of 5 GHz Unlicensed Band used by LAA and LTE-U

**HPUE** Supports tests of HPUE (High Power User Equipment) which is the specification to improve communication environment by increasing out put power of UE

**5G NSA Anchor** Supports 5G NSA (Non-Standalone) tests by interlocking with Radio Communication Test Station MT8000A

\*: Under the condition of 8CC 4x4 MIMO (32 layer)

# MT8821C

Wireless Communication Tester for LTE-Advanced UE Development

LTE/LTE-Advanced  
W-CDMA/HSPA  
Cat-M/NB-IoT (Cat-NB1, 2)  
GSM/EGPRS  
TD-SCDMA/HSPA





## Enhanced GUI for Efficient Operability

Better operability and visibility have been achieved using an enhanced next-generation GUI and easy-to-use large touch panel.

As well as operating screens by touching and swiping, easy operation is supported by one-touch switching between grouped/individual graph lists and results outline/detail displays.

Further, the efficiency of complex setting work is improved by a parameter search function, bookmarking function for commonly used parameters, and a function for setting test parameters using one-touch button operation.

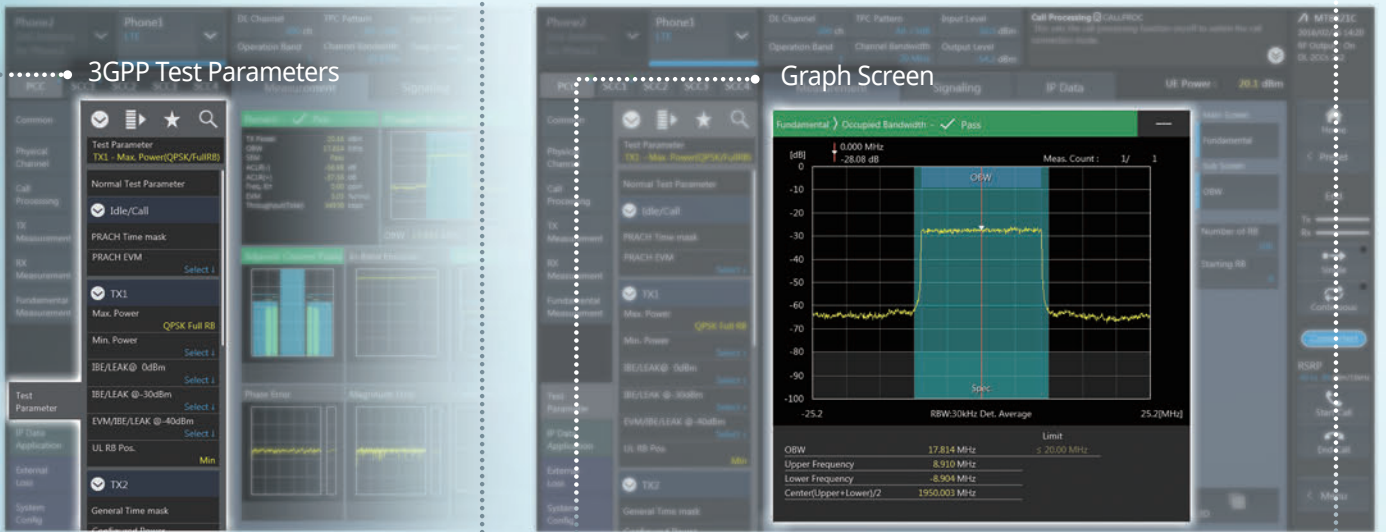
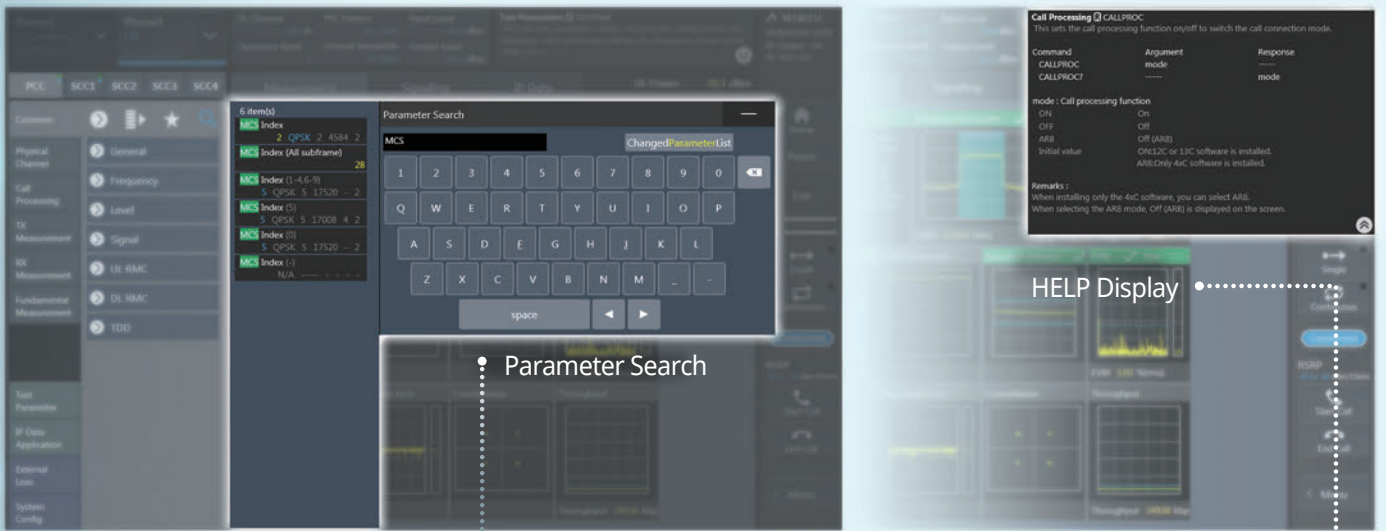

# The Wireless Communication Tester for Future UE Development

Easy 3GPP/3GPP2 RF measurement and flexible support for changing detailed test conditions  
Various fast RF calibrations offered by chipset vendors

**RF**  
TRX Measurement / Calibration

**OTA**

Tests of UE antenna characteristics

**Power Consumption Testing**

Tests of UE power consumption

**Inter-RAT Measurement**

Supports confirmation of dual-mode UE operation

**End-to-End Communication Testing**

IP data throughput, Voice, and Video tests

**VoLTE**

Tests of VoLTE voice/video echoback



# MT8821C

# Radio Communication Analyzer MT8821C Features

## RF TRX Measurement

### 3GPP UE RF Measurement

The UE TRX characteristics must be evaluated for compliance with 3GPP/3GPP2 standards at chipset and UE development, evaluation, and acceptance testing by network operators, etc. UE circuits are becoming increasingly complex as more communications technologies and frequency bands are supported; with built-in support for the UE RF TRX tests compliant with the various communications standards, the MT8821C is the ideal test solution whatever the measurement scenario.

### Supported 3GPP/3GPP2 Standards

Support Systems	RF TRX Measurements
LTE FDD/TDD (DL CA 2CC/3CC/4CC/5CC/6CC/7CC/8CC, UL CA 2CC)	3GPP TS 36.521-1 Chapter 6, 7
Cat-M	
NB-IoT (Cat-NB1, 2)	
W-CDMA (HSPA, HSPA Evolution, (DB-)DC-HSDPA, 3C/4C-HSDPA, DC-HSUPA)	3GPP TS 34.121-1 Chapter 5, 6
GSM (GPRS, EGPRS)	3GPP TS 51.010-1 Chapter 12, 13, 14
TD-SCDMA (HSPA, HSPA Evolution)	3GPP TS 34.122 Chapter 5, 6

### One-touch Settings and PASS/FAIL Judgment

With preset measurement parameters based on the 3GPP RF test standard cases, the MT8821C simplifies measurement. In addition, PASS/FAIL judgment of measurement results according to the test standard conditions is automated and results are confirmed at a glance.

Until now, LTE CA measurements have required complex Component Carrier (CC) settings, making operation difficult, but the MT8821C integrates multiple related parameters settings into one operation, greatly simplifying each operation stage to reduce setting operations and time.

For example, only the following three steps are required using the LTE measurement software to measure the 3GPP TS 36.521-1 6.5.2.1 Error Vector Magnitude (EVM):

- 1 Select test parameters
- 2 Start measurement
- 3 Confirm PASS/FAIL judgment



3GPP RF Test Example

### Remote Control Sample Tool

The MT8821C can be configured in an automated test system using either GPIB or Ethernet for remote control. Anritsu also provides the 3GPP RF test standard compliant automatic remote control sample tool.

Operation is as simple as selecting the required test case from RF test items in the remote control sample tool, so even new users can easily configure automated test environment.

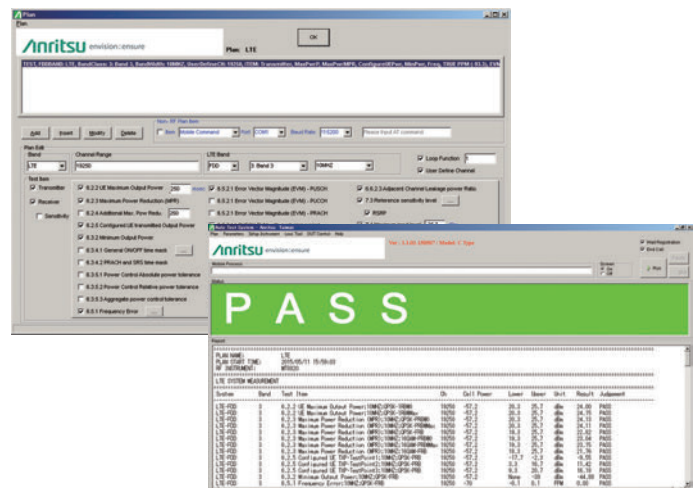

Remote Control Sample Tool

# Radio Communication Analyzer MT8821C Features

## RF TRX Measurement (continued)

### Flexible Parameter Setting

The MT8821C runs TRX measurements using parameters specified by the 3GPP/3GPP2 RF test standards. In addition, flexible parameter settings support both RF parametric and a range of protocol testing.

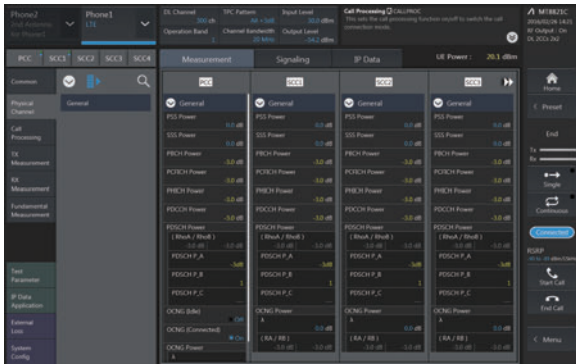

LTE Parameters

### High Efficiency with Shorter Test Time

Test time is shortened for better efficiency by integrating multi-systems (several communications technologies) into one test by leveraging functions such as Circuit Switched fallback (CSFB), Inter-RAT handover, etc. These functions support testing without needing to switch between tester RF connectors or power-down and up again repeatedly.

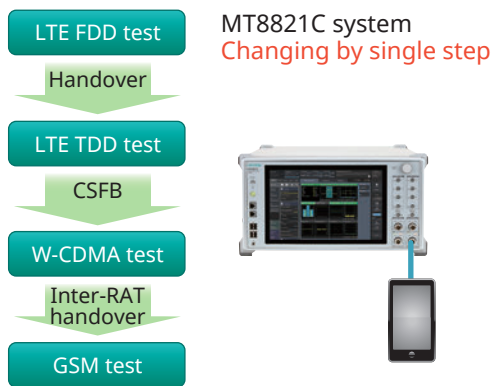

Test Example

### Built-in Combiner

With its built-in combiner, the MT8821C eliminates the need to configure a complex test system using external parts, as well as troublesome calibration.

#### Existing Model

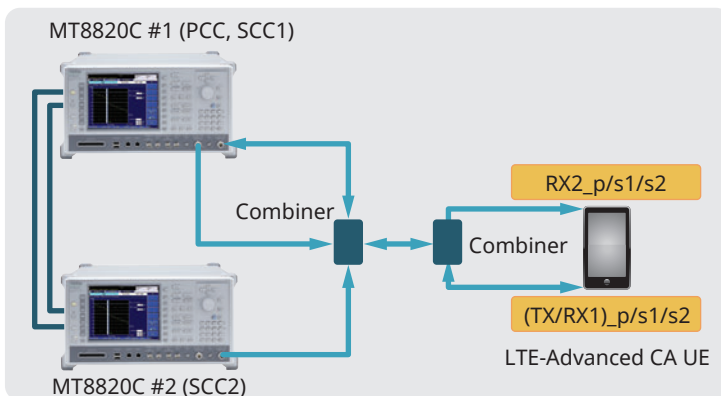

LTE-Advanced DL CA 3CC (SISO) Connection

#### MT8821C

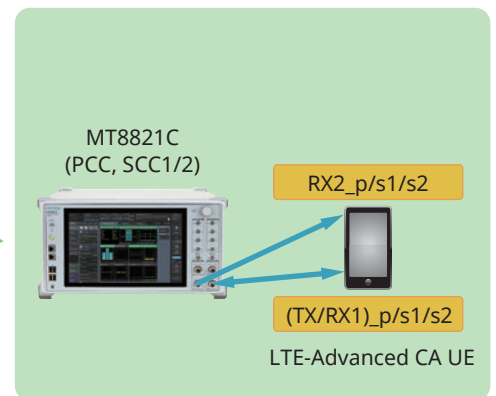

### RF Calibration

Recent UE designs support multiple frequency bands, requiring a lot of time for RF calibration. With high-speed measurement supported by chipset vendors, the MT8821C increases measurement efficiency by reducing time required for RF calibration.

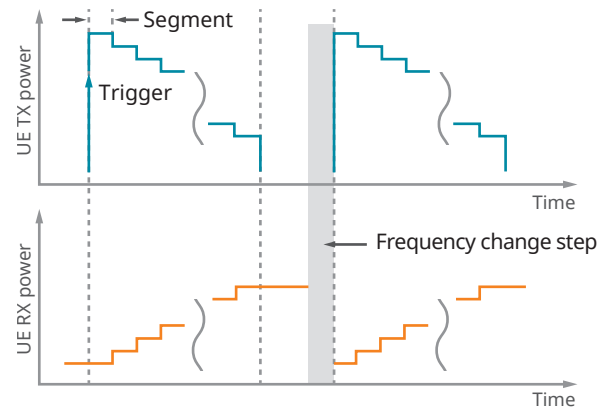

UE TRX Calibration

# Radio Communication Analyzer MT8821C Features

## Functional Testing

### Over The Air (OTA) Testing

The UE TRX performance is affected by factors such as the antenna form and characteristics. The OTA test measures the total UE TRX performance using actual radio waves reaching the antennas.

The MT8821C supports the various OTA vendor test system configurations in compliance with the 3GPP TS 34.114 and CTIA Total Radiated Power (TRP), and Total Radiated Sensitivity (TRS) test standards.

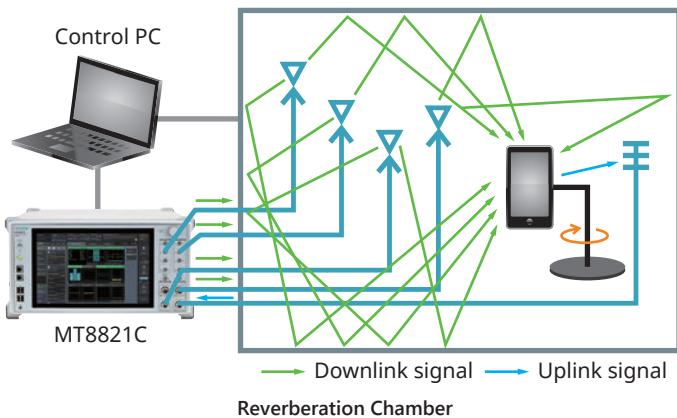
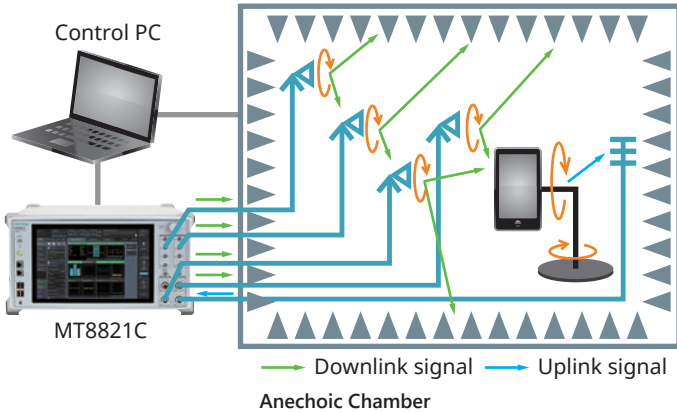

Moreover, it also supports the increasing number of test conditions demanded by higher antenna counts in UE units supporting LTE-Advanced CA and MIMO standards. Last, the shorter test time resulting from stable call processing performance is a key advantage of the MT8821C in various OTA test systems.

Support Systems	TRP	TRS	Comment
LTE FDD	✓	✓	SISO, 2×2 MIMO, 4×4 MIMO, DL CA 2CC/3CC/4CC/5CC/6CC/7CC/8CC, UL CA 2CC
LTE TDD	✓	✓	SISO, 2×2 MIMO, 4×4 MIMO, DL CA 2CC/3CC/4CC/5CC/6CC/7CC/8CC, UL CA 2CC
Cat-M	✓	✓	
NB-IoT	✓	✓	Cat-NB1, 2
W-CDMA	✓	✓	HSPA, HSPA Evolution, DC-HSDPA
GSM	✓	✓	
GPRS/EGPRS	✓	✓	
TD-SCDMA	✓	✓	HSPA

Although one MT8821C unit can output up to 8 independent signals, DL 4CA 4×4 MIMO measurements require output of 16 signals. Using two linked MT8821C units supports unrestricted frequency allocation and bandwidth settings for all four CCs, enabling DL 4CA 4×4 MIMO measurements.

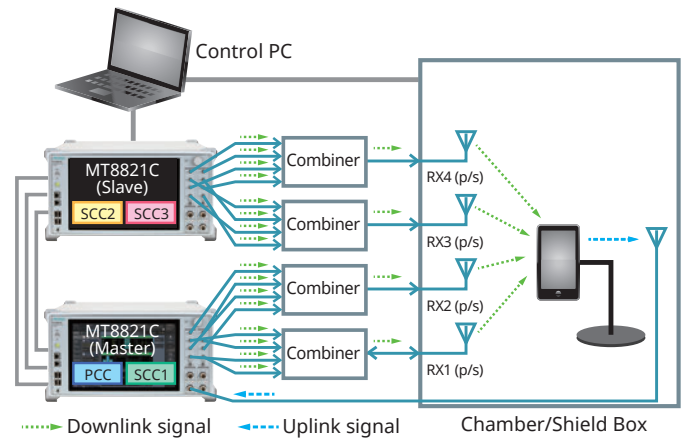

### SAR (Specific Absorption Rate) Test

The SAR test evaluates the amount of energy in the electromagnetic waves radiated from a UE that is absorbed by a jig called a 'phantom' mimicking the human body. This test is designed to protect the health of UE users from the effects of electromagnetic waves.

The basic amount of absorbed energy is determined by the standard for each country and region. The MT8821C supports the SAR test for each type of communication system.

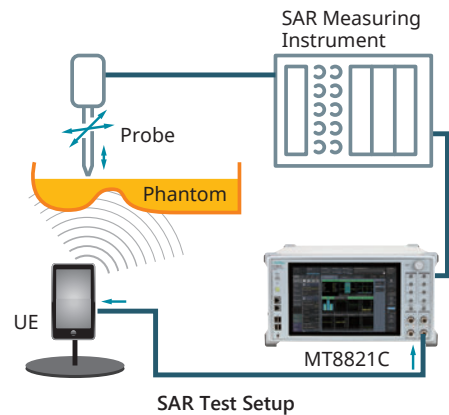

### 5G NSA (Non-Standalone) Testing

At the initial stage of 5G, NSA is considered as the main service form by many network operators who consider to realize 5G first network by adding 5G cell function to the existing LTE network. MT8821C can be the Anchor at 5G NSA call processing test by combining with Radio Communication Test Station MT8000A.

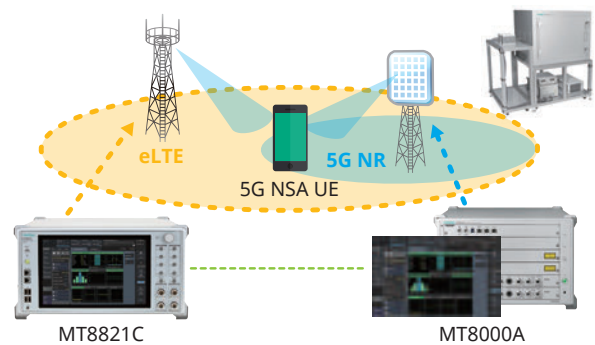

# Radio Communication Analyzer MT8821C Features

## Functional Testing (continued)

### Power Consumption Testing

Battery power consumption is a key point in differentiating chipsets and smartphones. As well as supporting the GSMA-defined power consumption tests, the MT8821C also supports power consumption tests at the maximum IP data throughput.

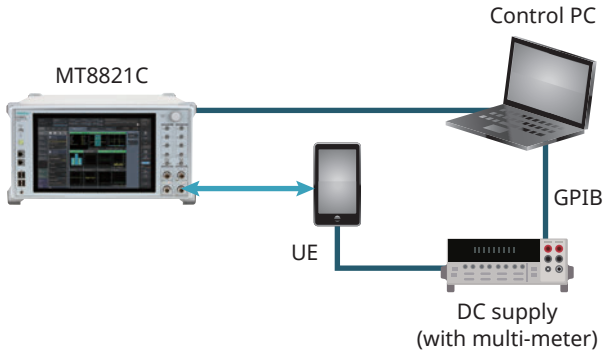

Power Consumption Test

Category	Procedure	Support Systems	Packet Rate (bps)
Power Consumption	Standby Time Test	GSM	
		W-CDMA	
		LTE	
	MOMR: Talk Time Test	GSM	
		W-CDMA	
	MTNR: Talk Time Test	GSM	
		W-CDMA	
	Video Telephony Test	W-CDMA	
Packet Switch Transfer Test (Download)	LTE	DL 5.16M, UL 5.54M @ 10 MHz	
Packet Switch Transfer Test (Upload)	LTE	DL 5.16M, UL 5.54M @ 10 MHz	
Packet Switch Transfer Test (Download/Upload)	LTE	DL 21.4M, UL 22.9M @ 10 MHz	

### Inter-RAT Measurement, DSDA RF Testing

The all-in-one MT8821C can test two communications technologies simultaneously. As well as testing two UE units at the same time, it can also perform RF tests of a Dual SIM Dual Active (DSDA) dual-mode UE with two separate communications technologies for standby and communications. It also supports Inter-RAT tests reporting the TX powers of base stations using different communications technologies to the UE.

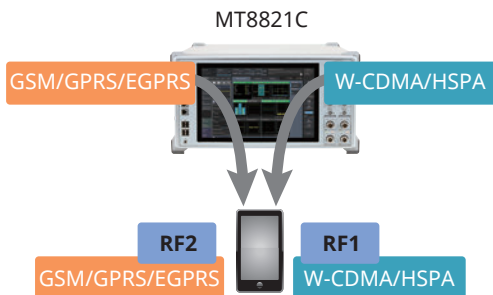

### VoLTE Voice/Video Echoback Testing

As VoLTE offering high-quality and low-latency voice calls becomes the de facto communications technology for recent UE, there is increasing demand for power consumption measurements during VoLTE calls as well as for confirmation of VoLTE call operations. However, setting the VoLTE IMS server is difficult.

With its built-in IMS server, the MT8821C reduces test preparation time and supports efficient VoLTE voice/video echoback tests, because the LTE measurement software GUI operations are also reflected at the IMS server.



### End-to-End Communication Testing

As well as evaluating UE RF performance, the MT8821C also supports functional tests, such as IP data throughput, audio/video tests, etc. Video calls between two UE units can be tested using one MT8821C with installed Parallel Phone measurement option. Furthermore, with its built-in application server function, smartphone and tablet IP data throughput tests require only the MT8821C and UE.

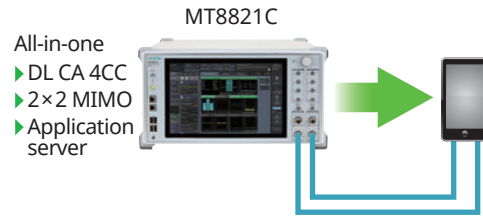

## Backwards Compatibility

### Remote Command

Since the MT8821C remote commands maintain good backwards compatibility with legacy MT8820 series, previously used remote tools are supported, helping reduce costs when configuring automated test environments.

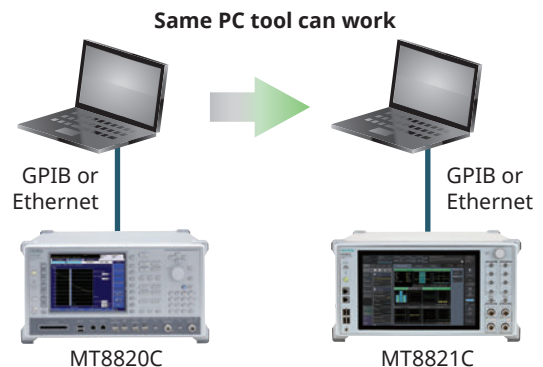

### MT8820C to MT8821C Upgrade

Anritsu offers an upgrade path from the MT8820C to the MT8821C making full use of the existing MT8820C hardware and software to maximize previous investment in the MT8820C and keep MT8821C costs down.

# Radio Communication Analyzer MT8821C Configurations

## System Configurations/Options/Software

Support Systems		LTE		IoT		W-CDMA	GSM	TD-SCDMA	HSPA	SEQ	
		FDD	TDD	Cat-M	NB-IoT						
Main Frame		MT8821C Radio Communication Analyzer									
Unit Options		MT8821C-012 Parallel Phone Measurement Hardware									
Unit Options		MT8821C-025 2nd RF for Phone1									
		MT8821C-026 3rd RF for Phone1									
		MT8821C-027 4th RF for Phone1									
		MT8821C-028 2nd RF for Phone2									
		MT8821C-029 3rd RF for Phone2									
Basic Configurations		Soft ware	MX882112C LTE FDD Measurement Software	MX882113C LTE TDD Measurement Software	MX882116C LTE Category M1 Measurement Software	MX882117C NB-IoT Measurement Software	MX882100C W-CDMA Measurement Software	MX882101C GSM Measurement Software	MX882107C TD-SCDMA Measurement Software	MX882115C W-CDMA HSPA Evolution IP Data Transfer	MX882120C Sequence Measurement Software
		Hard ware	MT8821C-008 LTE Measurement Hardware				MT8821C-001 W-CDMA Measurement Hardware	MT8821C-002 TDMA Measurement Hardware	MT8821C-001 W-CDMA Measurement Hardware	MT8821C-007 TD-SCDMA Measurement Hardware	MT8821C-008 LTE Measurement Hardware
Options		MX882164C LTE VoLTE Echoback		—							
		MX882112C-010 LTE FDD Anchor for 5G NSA	MX882113C-010 LTE TDD Anchor for 5G NSA	MX882116C-006 LTE Category M1 IP Data Transfer	MX882117C-001 NB-IoT Category NB-2 Measurement Software	MX882100C-019 W-CDMA HSPA Measurement Software	MX882101C-011 EGPRS Measurement Software	MX882107C-011 TD-SCDMA HSDPA Measurement Software	MX882115C-001 DC-HSDPA IP Data Transfer	MX882120C-001 W-CDMA Measurement Software	
		MX882112C-021 LTE-Advanced FDD DL CA Measurement Software	MX882113C-021 LTE-Advanced TDD DL CA Measurement Software		MX882117C-002 NB-IoT Multi Carrier	MX882100C-032 DC-HSDPA Measurement Software		MX882107C-012 HSDPA Evolution Measurement Software		MX882120C-002 GSM Measurement Software	
		MX882112C-022 LTE-Advanced FDD UL CA Measurement Software	MX882113C-022 LTE-Advanced TDD UL CA Measurement Software		MX882117C-006 NB-IoT IP Data Transfer	MX882100C-033 DC-HSUPA Measurement Software		MX882107C-021 TD-SCDMA HSUPA Measurement Software		MX882120C-004 LTE Measurement Software	
		MX882112C-031 LTE-Advanced FDD DL CA 3CCs Measurement Software	MX882113C-031 LTE-Advanced TDD DL CA 3CCs Measurement Software			MX882100C-034 4C-HSDPA Measurement Software				MX882120C-005 TD-SCDMA Measurement Software	
		MX882112C-041 LTE-Advanced FDD DL CA 4CCs Measurement Software	MX882113C-041 LTE-Advanced TDD DL CA 4CCs Measurement Software								
		MX882112C-051 LTE-Advanced FDD DL CA 5CCs Measurement Software	MX882113C-051 LTE-Advanced TDD DL CA 5CCs Measurement Software								
		MX882112C-061 LTE-Advanced FDD DL CA 6CCs Measurement Software	MX882113C-061 LTE-Advanced TDD DL CA 6CCs Measurement Software								
		MX882112C-071 LTE-Advanced FDD DL CA 7CCs Measurement Software	MX882113C-071 LTE-Advanced TDD DL CA 7CCs Measurement Software	—							
		MX882112C-081 LTE-Advanced FDD DL CA 8CCs Measurement Software	MX882113C-081 LTE-Advanced TDD DL CA 8CCs Measurement Software								
		MX882112C-011 LTE FDD 2x2 MIMO DL	MX882113C-011 LTE TDD 2x2 MIMO DL								
		MX882112C-012 LTE FDD 4x4 MIMO DL	MX882113C-012 LTE TDD 4x4 MIMO DL								
		MX882112C-006 LTE FDD IP Data Transfer	MX882113C-006 LTE TDD IP Data Transfer								
		MX882112C-026 LTE-Advanced FDD DL CA IP Data Transfer	MX882113C-026 LTE-Advanced TDD DL CA IP Data Transfer								
		MX882112C-036 LTE-Advanced FDD DL CA 3CCs IP Data Transfer	MX882113C-036 LTE-Advanced TDD DL CA 3CCs IP Data Transfer								
		MX882112C-046 LTE-Advanced FDD DL CA 4CCs IP Data Transfer	MX882113C-046 LTE-Advanced TDD DL CA 4CCs IP Data Transfer								

# Radio Communication Analyzer MT8821C Panel Layout

## Front Panel



### 1 Local Key

Switches from remote control operation mode to local control mode.

### 2 Power Switch

Turns on the power and illuminates green when MT8821C is operating (power on state).

### 3 Handset 1/2 Connector

For connection to a handset used for voice call testing of Phone 1/2.

### 4 USB Connector

Four USB 2.0 interface ports for connection to USB memory, mouse and keyboard.

### 5 Ground Terminal

Functional ground terminal (electrostatic discharge).

### 6 Display

Displays MT8821C's operation screen, in which you can set measurement parameters and view measurement results, by touch operation.

### 7 Rotary Control

Rotate: Moves the cursor and selects parameters.  
Press: Allows the selected parameter to be edited and saves the new parameter setting.

### 8 Phone 1/2\* Aux Output Connector

RF output connectors for RF measurement of Phone 1/2.

### 9 External SG Input Connector

Input connector for RF measurement signals for Phone 1 from an external signal generator.  
The input signal is output from the Main connectors 1 and 2 by combining with output signals of Phone 1.

### 10 External SA Output Connector

Output connector for monitoring RF measurement signals for Phone 1 at the external measuring device.

### 11 Phone 1/2 Main Connector

Input/output connectors for RF measurement signals for Phone 1/2.

# Radio Communication Analyzer MT8821C Panel Layout

## Rear Panel

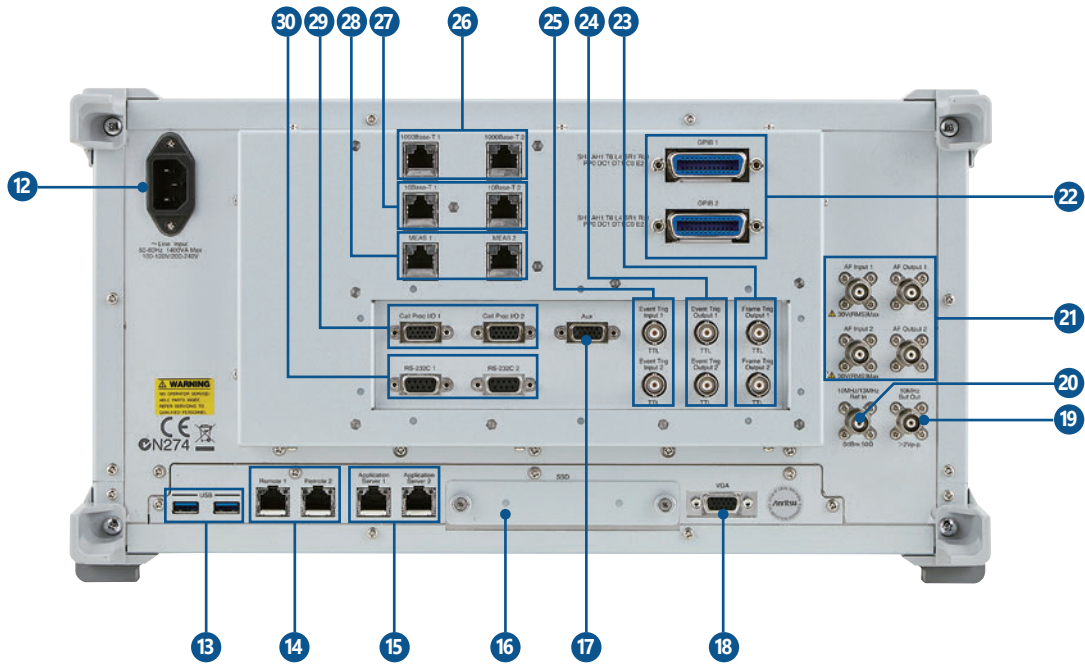

### 12 AC Inlet

AC power inlet for the power cable.  
With automatic voltage switching: 100 V(ac) to 120 V(ac)/  
200 V(ac) to 240 V(ac).

### 13 USB Connector

Two USB 3.0 interface ports for connection to USB memory,  
mouse, and keyboard.

### 14 Remote 1/2\*

For remote control of Phone 1/2 of MT8821C, via  
10/100/1000BASE-T.

### 15 Application Server Port 1/2\*

Interface for IP data transfer test.

### 16 SSD Slot

Slot for a 2.5-inch SSD.

### 17 Aux Connector

ARB input/output interface for Phone 1/2.

### 18 VGA Connector

Output interface for an external monitor.

### 19 Reference Signal Output Connector

Output connector for outputting reference signals from  
MT8821C.

### 20 Reference Signal Input Connector

Input connector for inputting external reference signals.

### 21 Audio Input/Output Connector 1/2\*

Input/output connectors for AF measurement of Phone 1/2  
(valid when the Voice Codec and Audio Board options are  
installed).

### 22 GPIB Connector 1/2\*

For remote control of Phone 1/2 of MT8821C, via GPIB.

### 23 Frame Trigger Output Connector 1/2\*

Output connectors for outputting frame-timing signals to an  
external device for Phone 1/2.

### 24 Event Trigger Output Connector 1/2\*

Output connectors for outputting event-timing signals to an  
external device for Phone 1/2.

### 25 Event Trigger Input Connector 1/2\*

Input connectors for inputting trigger signals from an  
external device to perform TX measurement of Phone 1/2, in  
synchronization with the external device.

### 26 1000BASE-T Port 1/2\*

Interface for communication test of Phone 1/2.  
(for LTE)

### 27 10BASE-T Port 1/2\*

Interface for communication test of Phone 1/2.  
(for W-CDMA, GSM)

### 28 MEAS Port 1/2

Not available.

### 29 Call Processing I/O Port 1/2\*

Interface for call processing test of Phone 1/2.

### 30 RS-232C Port 1/2\*

Interface for communication test of Phone 1/2.

\*: Enabled when Parallel Phone Measurement option installed in MT8821C.

# Radio Communication Analyzer MT8821C Specifications

Receiver	<p>Frequency range: 30 MHz to 3.8 GHz            30 MHz to 6.0 GHz (with MT8821C-019)</p> <p>Maximum input level: +35 dBm (Main 1, 2)            +10 dBm (SG Input)</p>
Transmitter	<p>Frequency            Output frequency range: 30 MHz to 3.8 GHz            30 MHz to 6.0 GHz (with MT8821C-019)</p> <p>Setting resolution: 1 Hz            Accuracy: Depends on reference oscillator accuracy</p> <p>Output level            Level range            Main 1, 2: -140 to -10 dBm (Internal signal generator TX 1 output)            -140 to -16 dBm (Internal signal generator TX 2, 3, or 4 output)            (with MT8821C-025, 026, 027 or with MT8821C-012, 028, 029, 030)</p> <p>Aux 1, 2, 3, 4: -125 to +5 dBm            (Aux 2, 3, 4: With MT8821C-025, 026, 027 or with MT8821C-012, 028, 029, 030)</p> <p>Resolution: 0.1 dB</p> <p>Level accuracy            10°C to 40°C, After Cal            Main 1, 2            Level: <math>\geq -120</math> dBm, SG Input: Off            When outputting from either of Main 1 or 2.            Except effect of noise floor from the other internal signal generators.  <math>\pm 1.5</math> dB (Frequency &lt; 350 MHz, Internal signal generator TX 1 output)  <math>\pm 1.0</math> dB, <math>\pm 0.7</math> dB (typ.) (350 MHz <math>\leq</math> Frequency <math>\leq</math> 3.8 GHz)  <math>\pm 1.3</math> dB, <math>\pm 1.0</math> dB (typ.) (3.8 GHz &lt; Frequency <math>\leq</math> 6.0 GHz)</p> <p>Aux 1, 2, 3, 4            Level: <math>\geq -110</math> dBm  <math>\pm 1.5</math> dB (Frequency &lt; 350 MHz)  <math>\pm 1.0</math> dB, <math>\pm 0.7</math> dB (typ.) (350 MHz <math>\leq</math> Frequency <math>\leq</math> 3.8 GHz)  <math>\pm 1.3</math> dB, <math>\pm 1.0</math> dB (typ.) (3.8 GHz &lt; Frequency <math>\leq</math> 6.0 GHz)</p> <p>Signal purity            Non-harmonic spurious: <math>\leq -30</math> dBc (offset frequency: <math>\geq 100</math> kHz)            Harmonics: <math>\leq -25</math> dBc</p>
Reference Oscillator	<p>Reference oscillator            Frequency: 10 MHz            Start-up characteristics: <math>\leq 5 \times 10^{-8}</math> (10 min. after power-on referenced to frequency 24-hour after power-on)            Aging rate: <math>\leq 2 \times 10^{-9}</math>/day, <math>\leq 1 \times 10^{-7}</math>/year (referenced to frequency 24-hour after power-on)            Temperature characteristics: <math>\leq 5 \times 10^{-8}</math>            Frequency accuracy before shipment: <math>\pm 2.2 \times 10^{-8}</math> (20°C to 30°C, 1 hour after power-on)            Output connector: BNC-J, Level: TTL</p> <p>External reference input            Frequency: 10 MHz or 13 MHz            Operating range: <math>\pm 1</math> ppm</p>
Display	<p>12.1-inch WXGA, 1280 <math>\times</math> 800 pixels, color TFT LCD            Touch panel: Projected capacitive type, multi-touch gestures</p>

# Radio Communication Analyzer MT8821C Specifications

<p>Front-panel Connectors</p>	<p>RF input/output</p> <p>Main 1, 2  Connector: N-J, 50Ω (nom.)  VSWR: ≤1.35 (30 MHz ≤ Frequency &lt; 350 MHz)  ≤1.30 (350 MHz ≤ Frequency &lt; 450 MHz)  ≤1.20 (450 MHz ≤ Frequency ≤ 1.6 GHz)  ≤1.30 (1.6 GHz &lt; Frequency ≤ 3.8 GHz) (Main 1)  ≤1.30 (1.6 GHz &lt; Frequency ≤ 2.7 GHz) (Main 2)  ≤1.35 (2.7 GHz &lt; Frequency &lt; 2.9 GHz) (Main 2)  ≤1.30 (2.9 GHz ≤ Frequency ≤ 3.8 GHz) (Main 2)  ≤1.40 (3.8 GHz &lt; Frequency ≤ 6.0 GHz)</p> <p>Aux 1, 2, 3, 4  Connector: SMA-J, 50Ω (nom.)  VSWR:  SG output level: ≤-10 dBm  ≤1.40 (30 MHz ≤ Frequency &lt; 300 MHz)  ≤1.30 (300 MHz ≤ Frequency ≤ 3.8 GHz)  ≤1.60 (3.8 GHz &lt; Frequency ≤ 6.0 GHz)</p> <p>SG Input  Connector: SMA-J, 50Ω (nom.)  VSWR: ≤1.40 (300 MHz ≤ Frequency ≤ 3.8 GHz)  ≤1.60 (3.8 GHz &lt; Frequency ≤ 6.0 GHz)</p> <p>Monitor  Connector: SMA-J, 50Ω (nom.)  VSWR: ≤1.30 (300 MHz ≤ Frequency ≤ 3.8 GHz)  ≤1.60 (3.8 GHz &lt; Frequency ≤ 6.0 GHz)</p> <p>Other  Handset 1, 2: For dedicated handset  Connector: RJ-12</p> <p>USB  Connector: USB 2.0, 4 ports</p>
-------------------------------	--

# Radio Communication Analyzer MT8821C Specifications

Rear-panel Connectors	<p>Reference signal</p> <p>10 MHz Buf Out: For internal reference oscillator output Connector: BNC-J Frequency: 10 MHz Level: TTL</p> <p>10 MHz/13 MHz Ref In: For external reference signal input Connector: BNC-J, 50Ω (nom.) Level: ≥0 dBm</p> <p>Control</p> <p> GPIB 1, 2: For remote control Interface function: SH1, AH1, T6, L4, SR1, RL1, PP0, DC1, DT1, C0, E2 Connector: GPIB (IEEE 488)</p> <p>Remote 1, 2 (Ethernet): For remote control Connector: RJ-45 (10/100/1000BASE-T)</p> <p>Data input/output</p> <p>Application Server 1, 2: For data transfer tests Connector: RJ-45 (1000BASE-T)</p> <p>RS-232C 1, 2: For data transfer tests Connector: D-sub 9-pin (RS-232)</p> <p>Call Proc I/O 1, 2: For call processing timing signal input/output Connector: Mini D-sub 15-pin Signal level: TTL, LVCMOS</p> <p>10BASE-T 1, 2: For data transfer tests Connector: RJ-45 (10BASE-T)</p> <p>1000BASE-T 1, 2: For data transfer tests Connector: RJ-45 (1000BASE-T)</p> <p>Aux: For ARB input/output Connector: Mini D-sub 15-pin Signal level: LVCMOS</p> <p>Trigger</p> <p>Frame Trig Output 1, 2: For frame trigger output</p> <p>Event Trig Input 1, 2: For event trigger input</p> <p>Event Trig Output 1, 2: For event trigger output Connector: BNC-J Signal level: TTL</p> <p>Audio</p> <p>AF Output 1, 2: For AF output Connector: BNC-J</p> <p>AF Input 1, 2: For AF input Connector: BNC-J Maximum input level: 30 V (RMS)</p> <p>Other</p> <p>USB: For general-purpose I/F Connector: USB 3.0, 2 ports</p> <p>VGA: For external display Connector: Mini D-sub 15-pin Signal level: Analog RGB</p> <p>MEAS 1, 2: Not used Connector: RJ-45</p>	
Storage Device	2.5-inch SSD	
Power Supply	100 V (ac) to 120 V (ac)/200 V (ac) to 240 V (ac) (250 V max.), 50 Hz/60 Hz ≤1200 VA (with all options)	
Dimensions and Mass	426 (W) × 221.5 (H) × 578 (D) mm (excluding projections) ≤40 kg (with all options)	
Environmental Conditions	Temperature and Humidity Operating: +5°C to +40°C, ≤90% RH (no condensation) Storage: -20°C to +60°C, ≤85% RH (no condensation)	
CE	EMC	2014/30/EU, EN61326-1, EN61000-3-2
	LVD	2014/35/EU, EN61010-1
	RoHS	2011/65/EU, (EU) 2015/863, EN IEC 63000: 2018
UKCA	EMC	S.I. 2016 No.1091, EN 61326-1, EN61000-3-2
	LVD	S.I. 2016 No.1101, EN 61010-1
	RoHS	S.I. 2012 No.3032, EN IEC 63000: 2018

Typical (typ.): Performance not warranted. Most products meet typical performance.  
Nominal (nom.): Values not warranted. Included to facilitate application of product.

# Radio Communication Analyzer MT8821C Ordering Information

Please specify the model/order number, name and quantity when ordering.

The names listed in the chart below are Order Names. The actual name of the item may differ from the Order Name.

Model/Order No.	Name	Remarks
MT8821C	<b>Main Frame</b> Radio Communication Analyzer	
P0031A W3753AE	<b>Standard Accessories</b> Power Cord: 1 pc USB Memory: 1 pc MT8821C Operation Manual: 1 pc	USB memory
MT8821C-001 MT8821C-002 MT8821C-007 MT8821C-008 MT8821C-012 MT8821C-019 MT8821C-025 MT8821C-026 MT8821C-027 MT8821C-028 MT8821C-029 MT8821C-030	<b>Options</b> W-CDMA Measurement Hardware TDMA Measurement Hardware TD-SCDMA Measurement Hardware LTE Measurement Hardware Parallel Phone Measurement Hardware*1 Extended RF 3.8 GHz to 6 GHz 2nd RF for Phone1 3rd RF for Phone1 4th RF for Phone1 2nd RF for Phone2 3rd RF for Phone2 4th RF for Phone2	Requires MT8821C-001      Requires MT8821C-025 Requires MT8821C-026 Requires MT8821C-012 Requires MT8821C-028 Requires MT8821C-029
MT8821C-□01 MT8821C-□02 MT8821C-□07 MT8821C-□08 MT8821C-□12	<b>Retrofit Options*2</b> W-CDMA Measurement Hardware Retrofit TDMA Measurement Hardware Retrofit TD-SCDMA Measurement Hardware Retrofit LTE Measurement Hardware Retrofit Parallel Phone Measurement Hardware Retrofit*1	Requires MT8821C-001
MX882100C MX882100C-002 MX882100C-003 MX882100C-005 MX882100C-019 MX882100C-032 MX882100C-033 MX882100C-034 MX882170C MX882101C MX882101C-002 MX882101C-005 MX882101C-011 MX882107C MX882107C-002 MX882107C-003 MX882107C-011 MX882107C-012 MX882107C-021 MX882112C MX882112C-006 MX882112C-010 MX882112C-011 MX882112C-012 MX882112C-016 MX882112C-021  MX882112C-022 MX882112C-026 MX882112C-031  MX882112C-036 MX882112C-041  MX882112C-046 MX882112C-051 MX882112C-061 MX882112C-071 MX882112C-081	<b>Software Options</b> W-CDMA Measurement Software W-CDMA External Packet Data W-CDMA Video Phone Test*3 W-CDMA A-GPS W-CDMA HSPA Measurement Software*3 DC-HSDPA Measurement Software DC-HSUPA Measurement Software 4C-HSDPA Measurement Software W-CDMA Ciphering Software*3 GSM Measurement Software GSM External Packet Data GSM A-GPS EGPRS Measurement Software TD-SCDMA Measurement Software TD-SCDMA External Packet Data TD-SCDMA Video Phone Test TD-SCDMA HSDPA Measurement Software TD-SCDMA HSDPA Evolution Measurement Software TD-SCDMA HSUPA Measurement Software LTE FDD Measurement Software LTE FDD IP Data Transfer LTE FDD Anchor For 5G NSA LTE FDD 2×2 MIMO DL LTE FDD 4×4 MIMO DL LTE FDD CS Fallback to W-CDMA/GSM LTE-Advanced FDD DL CA Measurement Software  LTE-Advanced FDD UL CA Measurement Software LTE-Advanced FDD DL CA IP Data Transfer LTE-Advanced FDD DL CA 3CCs Measurement Software  LTE-Advanced FDD DL CA 3CCs IP Data Transfer LTE-Advanced FDD DL CA 4CCs Measurement Software  LTE-Advanced FDD DL CA 4CCs IP Data Transfer LTE-Advanced FDD DL CA 5CCs Measurement Software LTE-Advanced FDD DL CA 6CCs Measurement Software LTE-Advanced FDD DL CA 7CCs Measurement Software LTE-Advanced FDD DL CA 8CCs Measurement Software	Requires MT8821C-001 Requires MX882100C Requires MX882100C Requires MX882100C Requires MX882100C Requires MT8821C-001 (2 sets), MT8821C-012, MX882100C and MX882100C-019 Requires MX882100C-032 Requires MX882100C-032 Requires MX882100C-032 Requires MX882100C Requires MT8821C-002 Requires MX882101C Requires MX882101C Requires MX882101C Requires MT8821C-007 Requires MX882107C Requires MX882107C Requires MX882107C Requires MX882107C-011 Requires MX882107C-011 Requires MX882107C-011 Requires MT8821C-008 Requires MX882112C Requires MT8000A and MX882112C Requires MT8821C-012 and MX882112C Requires MT8821C-026, MT8821C-029 and MX882112C-011 Requires MX882112C and MX882100C or MX882101C Requires MT8821C-025 and MX882112C Requires MT8821C-028 when MX882112C-011 installed Requires MX882112C-021 Requires MX882112C-006 and MX882112C-021 Requires MT8821C-008 (2 sets), MT8821C-026 and MX882112C-021 Requires MT8821C-029 when MX882112C-011 installed Requires MX882112C-026 and MX882112C-031 Requires MT8821C-027 and MX882112C-031 Requires MT8821C-030 when MX882112C-011 installed Requires MX882112C-036 and MX882112C-041 Requires MT8821C-012 and MX882112C-041 Requires MX882112C-051 Requires MX882112C-061 Requires MX882112C-061 Requires MX882112C-071

## Radio Communication Analyzer MT8821C Ordering Information

Model/Order No.	Name	Remarks
MX882113C	LTE TDD Measurement Software	Requires MT8821C-008
MX882113C-006	LTE TDD IP Data Transfer	Requires MX882113C
MX882113C-010	LTE TDD Anchor For 5G NSA	Requires MT8000A and MX882113C
MX882113C-011	LTE TDD 2x2 MIMO DL	Requires MT8821C-012 and MX882113C
MX882113C-012	LTE TDD 4x4 MIMO DL	Requires MT8821C-026, MT8821C-029 and MX882113C-011
MX882113C-016	LTE TDD CS Fallback to W-CDMA/GSM	Requires MX882113C and MX882100C or MX882101C
MX882113C-018	LTE TDD CS Fallback to TD-SCDMA/GSM	Requires MX882113C and MX882101C or MX882107C
MX882113C-021	LTE-Advanced TDD DL CA Measurement Software	Requires MT8821C-025 and MX882113C
MX882113C-022	LTE-Advanced TDD UL CA Measurement Software	Requires MT8821C-028 when MX882113C-011 installed
MX882113C-026	LTE-Advanced TDD DL CA IP Data Transfer	Requires MX882113C-021
MX882113C-031	LTE-Advanced TDD DL CA 3CCs Measurement Software	Requires MX882113C-006 and MX882113C-021
MX882113C-036	LTE-Advanced TDD DL CA 3CCs IP Data Transfer	Requires MT8821C-008 (2 sets), MT8821C-026 and MX882113C-021
MX882113C-041	LTE-Advanced TDD DL CA 4CCs Measurement Software	Requires MT8821C-029 when MX882113C-011 installed
MX882113C-046	LTE-Advanced TDD DL CA 4CCs IP Data Transfer	Requires MX882113C-026 and MX882113C-031
MX882113C-051	LTE-Advanced TDD DL CA 5CCs Measurement Software	Requires MT8821C-027 and MX882113C-031
MX882113C-061	LTE-Advanced TDD DL CA 6CCs Measurement Software	Requires MT8821C-030 when MX882113C-011 installed
MX882113C-071	LTE-Advanced TDD DL CA 7CCs Measurement Software	Requires MX882113C-036 and MX882113C-041
MX882113C-081	LTE-Advanced TDD DL CA 8CCs Measurement Software	Requires MT8821C-012 and MX882113C-041
MX882115C	W-CDMA HSPA Evolution IP Data Transfer	Requires MX882113C-051
MX882115C-001	DC-HSDPA IP Data Transfer	Requires MX882113C-061
MX882116C	LTE Category M1 Measurement Software	Requires MX882113C-071
MX882116C-006	LTE Category M1 IP Data Transfer	Requires MX882113C-081
MX882117C	NB-IoT Measurement Software	Requires MT8821C-008
MX882117C-001	NB-IoT Category NB-2 Measurement Software	Requires MX882115C
MX882117C-002	NB-IoT Multi Carrier	Requires MT8821C-008
MX882117C-006	NB-IoT IP Data Transfer	Requires MX882116C
MX882120C	Sequence Measurement Software	Requires MT8821C-008
MX882120C-001	W-CDMA Measurement Software	Requires MX882116C
MX882120C-002	GSM Measurement Software	Requires MT8821C-008
MX882120C-004	LTE Measurement Software	Requires MX882117C
MX882120C-005	TD-SCDMA Measurement Software	Requires MX882117C
MX882132C	CDMA2000 Measurement Software Lite	Requires MX882120C
MX882136C	1xEV-DO Measurement Software Lite	Requires MX882120C
MX882142C	LTE FDD Measurement Software Lite	Requires MX882120C
MX882143C	LTE TDD Measurement Software Lite	Requires MX882120C
MX882164C	LTE VoLTE Echoback	Requires MX882112C for LTE FDD, requires MX882113C for LTE TDD
MT8821C-UG□01	<b>Upgrade Kits*2</b> SPM Upgrade Kit from MT8820C	Required for additional purchase of software options, etc.
MT8821C-UG□02	PPM Upgrade Kit from MT8820C	
MT8821C-UG□03	SPM Upgrade Kit from MT8820C with MX88207xC	
MT8821C-UG□04	PPM Upgrade Kit from MT8820C with MX88207xC	
MT8821C-UG011	Software Upgrade Kit	
MT8821C-UG□10	CPU/Windows10 Upgrade Retrofit	
MT8821C-ES210	<b>Warranty Service</b> 2 years Extended Warranty Service	
MT8821C-ES310	3 years Extended Warranty Service	
MT8821C-ES510	5 years Extended Warranty Service	

## Radio Communication Analyzer MT8821C Ordering Information

Model/Order No.	Name	Remarks
	<b>Application Parts</b>	
P0035B	W-CDMA/GSM Test USIM	
P0035B7	W-CDMA/GSM Test USIM*4	Micro UICC size
P0135C6	Anritsu Test UICC GA*4, *5	Nano UICC size
P0135C7	Anritsu Test UICC GA*4, *5	Micro UICC size
P0135D6	Anritsu Test UICC GA*4, *5	Nano UICC size
P0135D7	Anritsu Test UICC GA*4, *5	Micro UICC size
P0250C6	Anritsu Test UICC GT*4, *5	Nano UICC size
P0250C7	Anritsu Test UICC GT*4, *5	Micro UICC size
P0250D6	Anritsu Test UICC GT*4, *5	Nano UICC size
P0250D7	Anritsu Test UICC GT*4, *5	Micro UICC size
P0260C6	Anritsu Test UICC GM*4, *5	Nano UICC size
P0260C7	Anritsu Test UICC GM*4, *5	Micro UICC size
P0260D6	Anritsu Test UICC GM*4, *5	Nano UICC size
P0260D7	Anritsu Test UICC GM*4, *5	Micro UICC size
P0551A	Anritsu Test UICC TM*4, *5	
P0551B	Anritsu Test UICC TM*4, *5	
P0435A6	Anritsu Test UICC GA for eDRX*4	Nano UICC size (for eDRX test)
P0435A7	Anritsu Test UICC GA for eDRX*4	Micro UICC size (for eDRX test)
A0058A	Handset	
P0031A	USB Memory	
Z0541A	USB Mouse	
Z0975A	Keyboard	USB connection
Z1898A	Connector Cap	
J1643A	U Link	N-P · UT-141 · SMA-P (for connecting Phone 2 Main1 - SG input)
J1644A	U Link	N-P · UT-141 · SMA-P (for connecting Phone 2 Main1 - Monitor)
J0004	Coaxial Adaptor	
J1195A	PP2S Output Cable	
J1249	CDMA2000 Cable	D-sub (15-pin, P-type) · D-sub (15-pin, P-type), used in combination with J1267 (sold separately)
J1267	CDMA2000 Cross Cable	D-sub (9-pin, P-type) · D-sub (9-pin, P-type), reverse cable used in combination with J1249 (sold separately)
J1606A	Cable	D-sub (15-pin, P-type) · D-sub (15-pin, P-type) · D-sub (15-pin, P-type)
J0576B	Coaxial Cord, 1 m	N-P · 5D-2W · N-P
J0576D	Coaxial Cord, 2 m	N-P · 5D-2W · N-P
J0127A	Coaxial Cord, 1 m	BNC-P · RG58A/U · BNC-P
J0127C	Coaxial Cord, 0.5 m	BNC-P · RG58A/U · BNC-P
J0007	GPIB Cable, 1 m	
J0008	GPIB Cable, 2 m	
J1261A	Ethernet Cable (Shield Type)	1 m, straight
J1261B	Ethernet Cable (Shield Type)	3 m, straight
MN8110B	I/O Adapter	For call processing I/O
B0332	Joint Plate	4 pcs/set
B0703A	Rack Mount Kit (MT8821C)	
B0701A	Carrying Case	Hard type (with protective cover and casters)
B0702A	Carrying Case	Hard type (with protective cover, without casters)
Z1858A	Divider	2-way divider
Z1859A	Divider	3-way divider
J0322A	Coaxial Cord, 0.5 m	SMA-P · SMA-P, DC to 18 GHz, 50Ω
J0322B	Coaxial Cord, 1.0 m	SMA-P · SMA-P, DC to 18 GHz, 50Ω
J0322C	Coaxial Cord, 1.5 m	SMA-P · SMA-P, DC to 18 GHz, 50Ω
J0322D	Coaxial Cord, 2.0 m	SMA-P · SMA-P, DC to 18 GHz, 50Ω
J1398A	N-SMA ADAPTOR	
J1802A	Sync Cable	

\*1: The following measurement hardware support the Parallelphone measurement option: MT8821C-001, MT8821C-002, MT8821C-007 and MT8821C-008.

All the measurement hardware can be installed simultaneously.

\*2: MT8821C- □ ##

□: Select from the following according to the option type.

1: Retrofit option (Must be returned to factory in Japan)

2: Retrofit option (Must be returned to service center outside of Japan)

\*3: For UE connectivity, contact your Anritsu sales representative.

\*4: A commercial SIM adapter CANNOT be used. If used, it may jam and break in the UE.

\*5: Refer to the P0135x/P0250x/P0260x/P0551x leaflet for details.

Parallelphone™ is a trademark of Anritsu Corporation.